

CATALOG | OCTOBER 2022

High voltage flameproof motors for explosive gas atmospheres

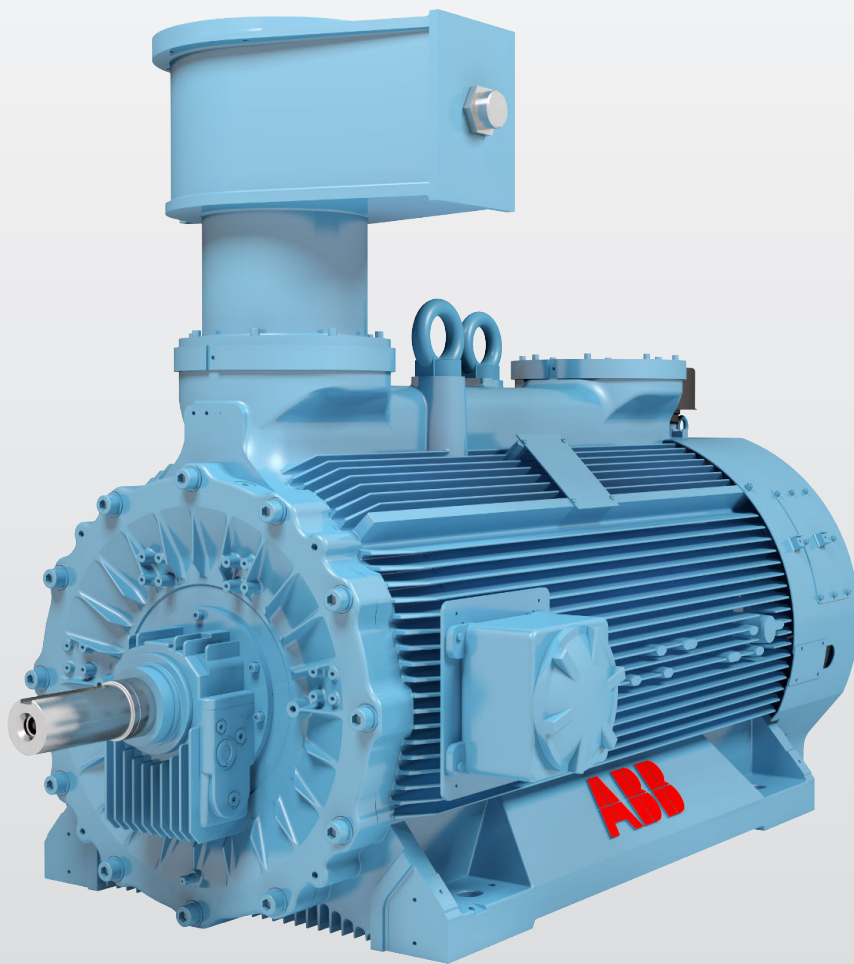

High voltage flameproof motors from ABB offer great performance, reliability and safety for applications in potentially explosive atmospheres.

With expertise, and a comprehensive portfolio of products and life-cycle services, we help value-minded industrial customers improve their energy efficiency and productivity.

High voltage flameproof motors for explosive gas atmospheres

04–05	What is a potentially explosive atmosphere?
06	Understanding the standards for explosive atmospheres
08–09	Main standards for explosive atmospheres
10–11	Groups
12–14	Zones, categories and equipment
15	Certification markings
16	Voltage and frequency
18–19	Range and Scope
20	Certificates
22	Stator and Insulation
23	Rotor and Vibrations
24–30	Antifriction bearing
31–33	Sleeve bearing
35	Terminal boxes for flameproof motors
36	Surface treatment
37	Mounting
38	Cooling
39	Degrees of protection: IP code and resistance to impact
40	Additional options
41	Rating plates
42	Electrical data
43–67	Technical data for totally enclosed squirrel cage three phase motors
68–79	Dimension drawings
80	Total product offering
81	Life cycle services and support



01



02



03



04



05

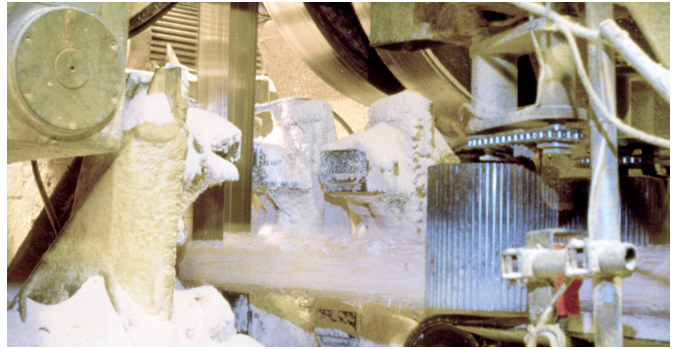

06



07



08



09



10

What is a potentially explosive atmosphere?

Explosive atmospheres occur when flammable gases, mist, vapors or dust mix with air. This creates the risk of an explosion. The amount of a substance needed to create an explosive atmosphere depends on the substance in question.

- 01 Oil and gas
- 02 Chemical industry
- 03 Mining
- 04 Water treatment
- 05 Food and beverage
- 06 Sawmills
- 07 Pharmaceutical
- 08 Textile industry
- 09 Marine
- 10 Power generation

The area where this possibility exists is defined as a **potentially explosive atmosphere**. These atmospheres can be found in many industries, from chemical, pharmaceutical and food, to power generation and wood processing. The areas may also be known as “hazardous areas” or “hazardous locations.”

The number of substances that are flammable when mixed with air is very large. This means there are many industrial sectors that can have a potentially explosive atmosphere somewhere in their process. Some of these are not so obvious. For example, sawmills by default are not a potentially explosive atmosphere, but if sawdust is allowed to collect in large amounts in one area, that area can become one.



Understanding the standards for explosive atmospheres

Globally, there are many regulations and certification systems with different requirements. The technical requirements in these regulations are becoming increasingly harmonized with the global IEC standards.

IECEX

The IECEx system (www.iecex.com) – from the International Electrotechnical Commission, is a voluntary certification system that verifies compliance with IEC standards related to safety in explosive atmospheres. IECEx covers four main areas:

- Certification of service facilities
- IECEx equipment certification
- Ex marking conformity
- Certification of Personnel Competencies

IECEX Conformity Mark System

In order for equipment to receive a conformity “Ex” marking under IECEx, it must obtain a certificate of conformity.

This requires:

- An accepted IECEx Quality Assessment Report (QAR)
- An accepted IECEx Test Report for type testing (ExTR)

Products with the IECEx conformity mark have received an IECEx Certificate of Conformity, which confirms that the product has the appropriate protection for use in explosive atmospheres and that it has been manufactured under a system subject to ongoing surveillance by certification bodies. The marking also indicates that the product can be supplied to the market without the need for additional testing. The exception is increased safety (Ex eb) motor protection type, which must always be tested with the drive it will be used with.

European Directives

Commonly referred to as ATEX, from the French “ATmosphères EXplosibles”, the European regulations combine two EU directives: the Worker Protection Directive (1999/92/EC) and the Product Directive (2014/34/ EU). The EU Directives have some difference from IECEx, and they do not include certification of service facilities or certification of personnel competencies. Compliance with the “Essential Health and Safety Requirements” described in the directives is mandatory within EU countries. The easiest way to show compliance is to follow harmonized standards.

Protective devices

Protective devices are often required by IEC 60079 series of standards for safe operation of Ex equipment. Protective devices can be located inside or outside explosive atmospheres. A typical example of a protective device is surface temperature protection for motors controlled by a variable-speed drive (VSD). This type of protective device is an alternative to a certified and tested combination of motor and VSD.

Protective devices for Ex equipment and products fall within the scope of the ATEX regulations: harmonized standard EN 50495:2010. IECEx does not have an applicable standard for electrical safety devices for Ex equipment, and therefore certification can only be done according to ATEX. However, a new IEC publication (IEC TS 60079-42) will give guidance on protective devices under IECEx. Also remember to always check the local regulations as well.



Main standards for explosive atmospheres

IEC and EN standards

- IEC 60050-426: International Electrotechnical Vocabulary (IEV) – Explosive atmospheres
- IEC/EN 60079-0: Equipment – General requirements
- IEC/EN 60079-1: Equipment protection by flameproof enclosures “d”
- IEC/EN 60079-7: Equipment protection by increased safety “e”
- IEC 60079-10-1: Classification of areas – Explosive gas atmospheres
- IEC 60079-10-2: Classification of areas – Combustible dust atmospheres
- IEC/EN 60079-14: Electrical installations design, selection and erection
- IEC/EN 60079-15: Equipment protection by type of protection “n” (no longer applicable to rotating machines)
- IEC/EN 60079-17: Electrical installations inspections and maintenance
- IEC/EN 60079-19: Equipment repair, overhaul and reclamation
- IEC/EN 60079-31: Equipment dust ignition protection by enclosure “t”

Regulations around the globe

CEC, CSA

NEC, CSA/US/UL

Inmetro

SABS

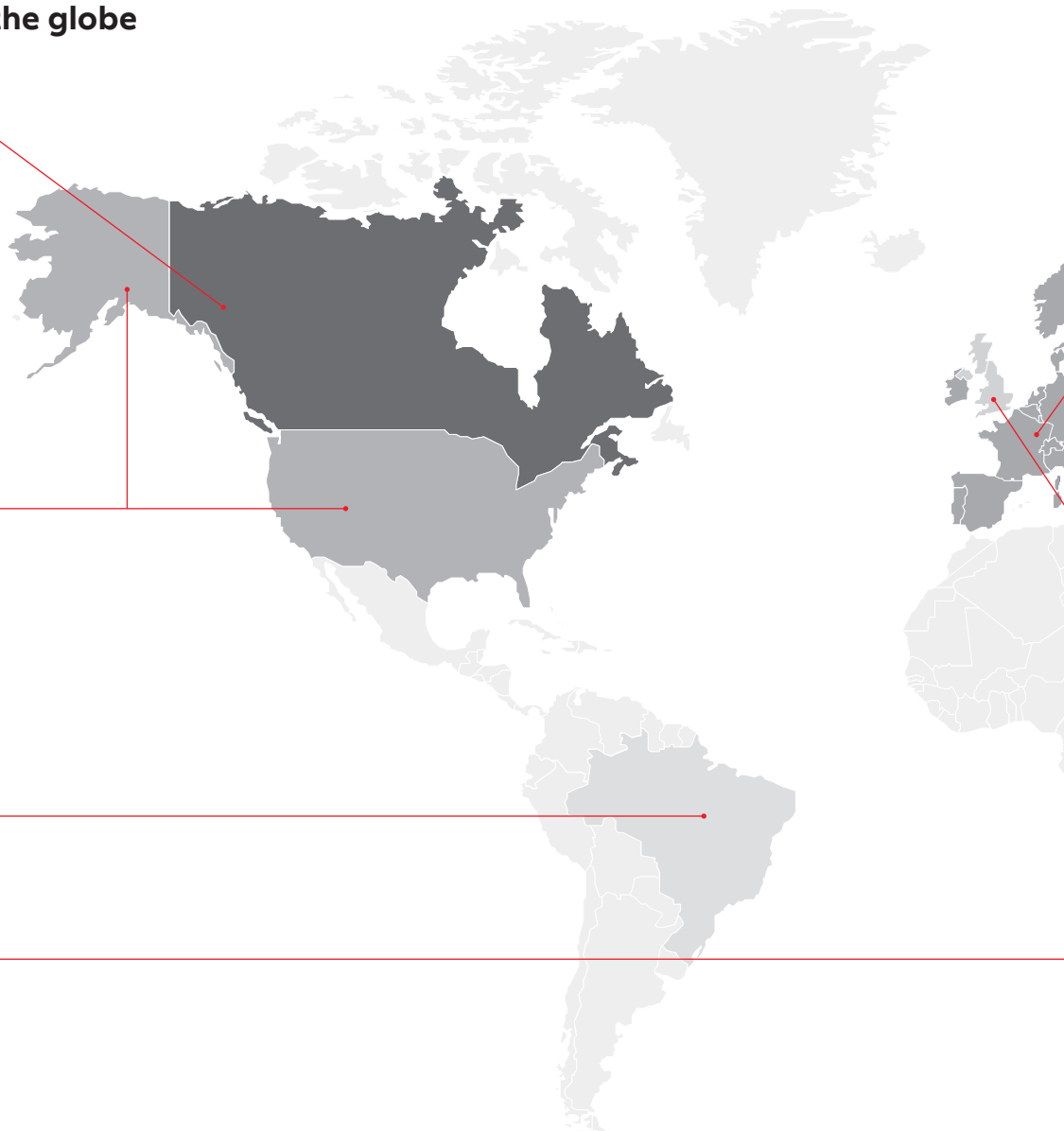

ATEX directives

The Worker Protection Directive (1999/92/EC) specifies the minimum health and safety requirements for workers performing duties in potentially explosive atmospheres.

The Product Directive (2014/34/EU) specifies requirements for equipment that is used in potentially explosive atmospheres. It also specifies the requirements for protective systems that are needed for equipment protection.

In addition to IECEx and ATEX there are several local standards that may be in effect in certain countries.

Other standards

Many countries have regulations concerning both the design and use of electrical devices in potentially explosive atmospheres, and these may differ. These regulations have become increasingly harmonized within the framework of IEC recommendations and European standards. National requirements may still need to be met for final approval of installation (e.g. in Russia, Brazil, Australia or Japan), but they generally relate to one of the main standards below.

- IEC: International Electrotechnical Commission
- EN: European standard
- NEC/CEC: National Electrical Code / Canadian Electric Code (500 or 505) in North America

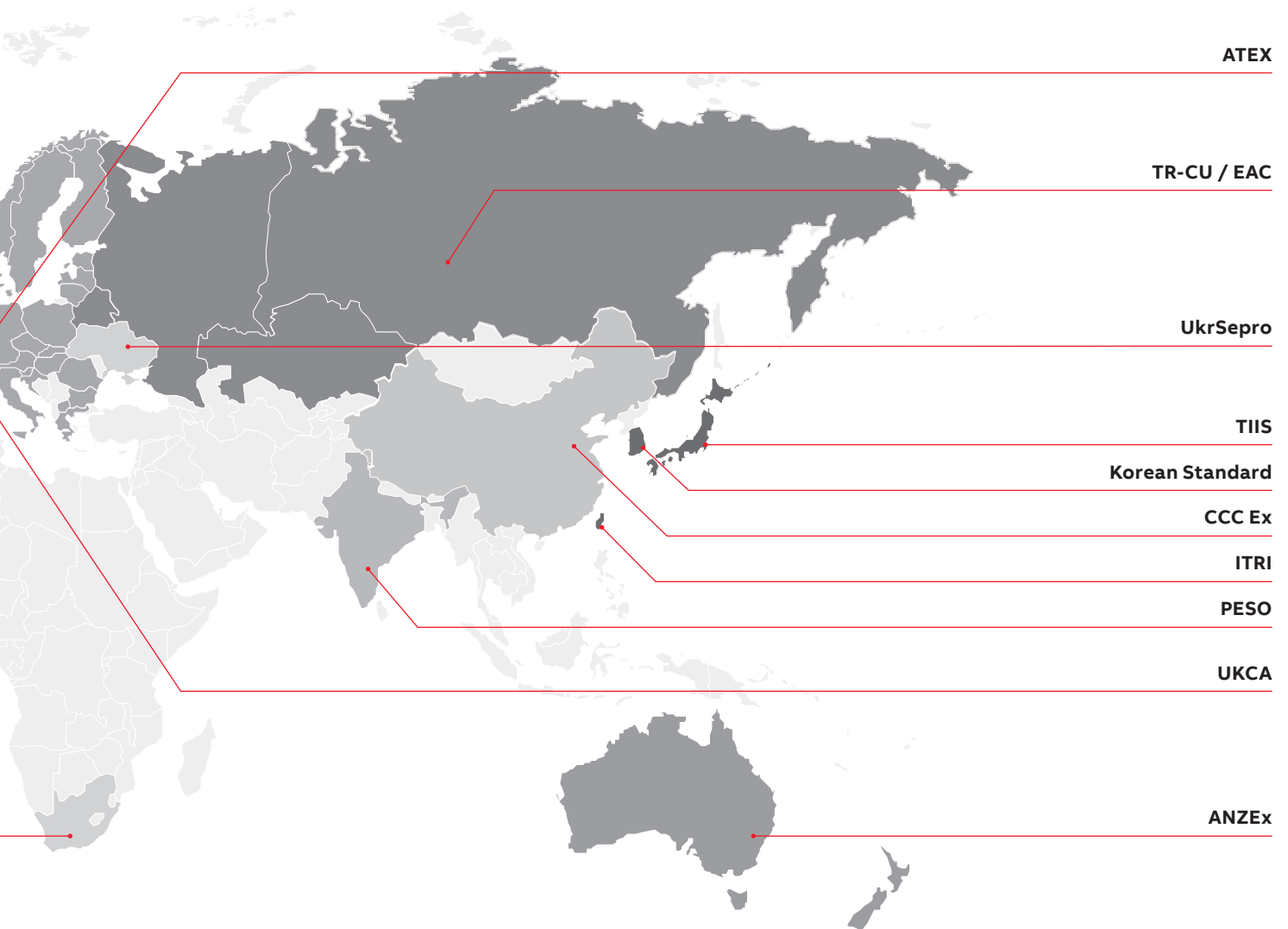

Groups

Groups

Internationally, IEC 60079-0 and EN 60079-0 in Europe define three groups for potentially explosive atmospheres: Group I covers underground mines or mines susceptible to firedamp. Group II relates to surface environments with gas, and Group III to surface environments with dust. The Product Directive defines only two groups: Group I for underground mines or mines endangered by firedamp and/or combustible dust, and Group II for all surface installations.

The group designation is essentially based on where equipment can be used (equipment classification).

Subgroups and temperature classes

Explosive gases, vapors and dusts have different chemical properties that affect the likelihood and severity of an explosion. Such properties include flame temperature, minimum ignition energy, upper and lower explosive limits, and molecular weight. Based on the nature of the explosive gas/dust, gases are grouped into IIA, IIB and IIC and dusts into IIIA, IIIB and IIIC.

Temperature classes are defined for equipment based on its maximum surface temperature. When selecting a piece of equipment for a potentially explosive atmosphere, the maximum surface temperature of the equipment must be lower than the ignition temperature of the potential gas or dust mixture.

Gas classification

Temp. class	Ignition temp. of gas/vapor (°C)	Max. permitted temp. of equipment (°C)	Gas examples
T1	> 450	450	Hydrogen
T2	> 300 but < 450	300	Ethanol
T3	> 200 but < 300	200	Hydrogen sulfide
T4	> 135 but < 200	135	Diethyl ether
T5	> 100 but < 135	100	–
T6	> 85 but < 100	85	Carbon disulfide

Gas subdivision

IIA	Approx. 120 gases and vapors, e.g. butane/petroleum/propane
IIB	Approx. 30 gases and vapors, e.g. ethylene/dimethyl ether/coke oven gas
IIC	Three gases: hydrogen (H ₂)/acetylene (C ₂ H ₂) / carbon disulfide (CS ₂)

Dust classification

		TCL (cloud) (°C)	T5mm (layer) (°C)	Surface temp. provided that dust layer below 5 mm
Food/feed industry	Wheat	350	270	195
	Barley, corn	380	280	205
	Sugar	350	430	233
Natural materials	Wood	330	280	205
	Charcoal	520	230	195
	Hard coal	460	240	165
Chemicals	PVC	450	330	255
	Synth. rubber	470	220	145
	Sulfur	240	250	160

Dust subdivision

IIIA	Combustible flyings
IIIB	Non-conductive dust
IIIC	Conductive dust

Relationships between ATEX directives

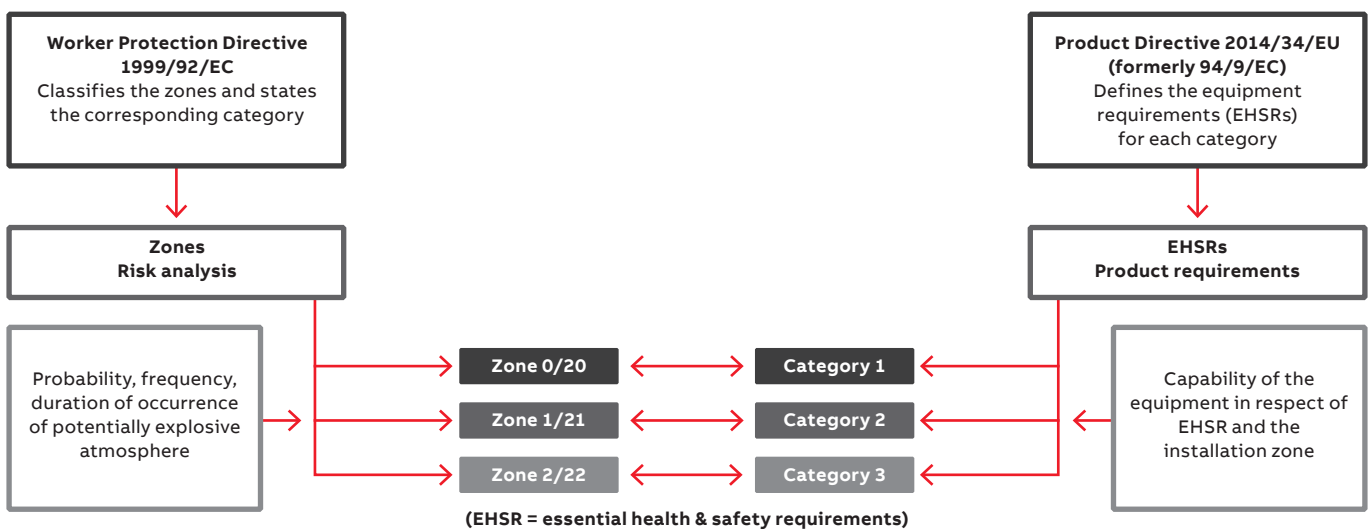

The manufacturer is responsible for product safety and for delivering installation and maintenance instructions. The Product Directive guides the manufacturer to prepare the product classification and to certify the product and production.

The end user is responsible for ensuring that the product is installed, maintained and operated in a way that does not pose any risk of explosion. The Worker Protection Directive guides end users to use certified products and to prepare risk analysis, safety instructions, training and procedures for operation and maintenance.

Zones, categories and equipment

New markings introduced

The latest revisions of the standards IEC/EN 60079-7 and IEC/EN 60079-1 have introduced some new markings for equipment suitable for locations where there is a potential risk of gas presence. The non-sparking protection method is no longer used on rotating electrical machines, there are instead two levels on increased safety protection introduced in edition 5 of IEC/EN 60079-7. One higher level of protection with EPL Gb that technically corresponds to

the old Ex e, and a new lower level with EPL Gc that corresponds to Ex nA as previously defined in IEC/EN 60079-15.

Furthermore several levels of protection have been introduced in edition 7 of IEC/EN 60079-1 for flame proof protection. These two changes affect the markings used for flameproof, increased safety and non-sparking equipment for group II as shown in table below.

Old way of marking	Old protection method	New way of marking	New protection method	Zone	ATEX category
Ex e IIC T3 Gb	Increased safety	Ex eb IIC T3 Gb	Unchanged	1 (or 2)	2G
Ex nA IIC T3 Gc	Non-sparking	Ex ec IIC T3 Gc	Increased safety	2	3G
Ex d IIB/C T4 Gb	Flameproof	Ex db IIB/C T4 Gb	Unchanged	1 (or 2)	2G
Ex de IIB/C T4 Gb	Flameproof and increased safety	Ex db eb IIB/C T4 Gb	Unchanged	1 (or 2)	2G

IECEX

Before: Ex nA IIC T3 Gc
Now: Ex ec IIC T3 Gc

Before: Ex e IIC T3 Gb/
Ex d IIB/C T4 Gb/Ex de IIB/C T4 Gb
Now: Ex eb IIC T3 Gb/
Ex db IIB/C T4 Gb/Ex db eb IIB/C T4 Gb

No motors allowed

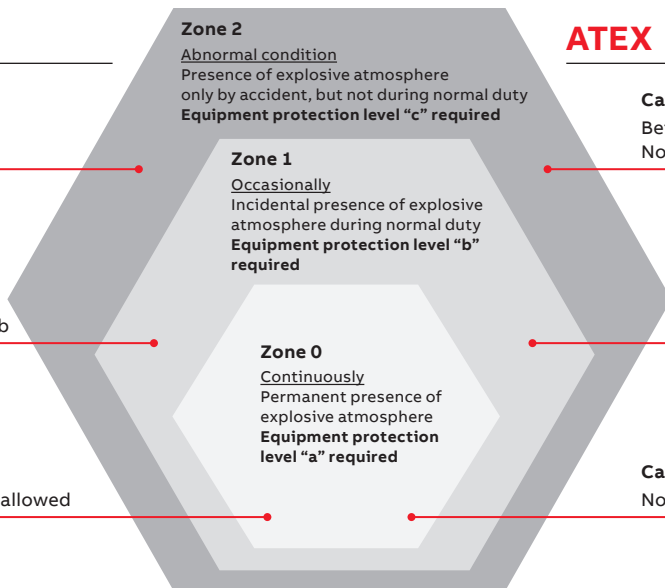

ATEX

Category 3
Before: II 3G Ex nA IIC T3 Gc
Now: II 3G Ex ec IIC T3 Gc

Category 2
Before: II 2G Ex e IIC T3 Gb / II 2G Ex d IIB/C T4 Gb / II 2G Ex de IIB/C T4 Gb
Now: II 2G Ex eb IIC T3 Gb / II 2G Ex db IIB/C T4 Gb / II 2G Ex db eb IIB/C Gb

Category 1
No motors allowed

Note: Based on traditional relationship between EPL's and zones.

There are systems in place worldwide to classify explosive atmospheres by zones, according to the risk posed by explosive gas (“G”) or dust (“D”).

Classification of explosive atmospheres according to CENELEC and IEC

The following standards define areas according to the presence of gas or dust in the atmosphere:

- IEC/EN 60079-10-1 Gas
- IEC/EN 60079-10-2 Dust

Standard IEC 60079-0 EN 60079-0		Installation Zone according to IEC 60079-10-x EN 60079-10-x		Main motor protection types	In addition for ATEX Directive 2014/34/EU (previously 94/9/EC)	
Group	EPL	Protection level	Zones		Equipment group	Equipment category
I (Mines)	Ma	Very high	The zone classification is not used in mines.	Ex db	I (Mines)	M1
	Mb	High				M2
II (Gas)	Ga	Very high	0	NA	II (Surface)	1G
	Gb	High	1	Ex db, Ex db eb, Ex pxb, Ex eb		2G
	Gc	Enhanced	2	Ex pzc, Ex ec		3G
III (Dust)	Da	Very high	20	NA	II (Surface)	1D
	Db	High	21	Ex tb IP6X		2D
	Dc	Enhanced	22	Ex tc IP6X/IP5X		3D

Equipment categories

Equipment categories are used in the ATEX directive. The category indicates which safety level must be used in each zone. In zone 0/20, category 1 devices must be used; in zone 1/21, category 2 devices; and in zone 2/22, category 3 devices.

Classification into categories is particularly important, because all the inspection, maintenance and repair duties of the end user will depend on the category of the product/equipment, not on the zone where it is installed.

Equipment protection levels (EPL)



The latest revisions of the IEC and EN standards include the concept of “equipment protection levels” (EPLs), which identify products according to the ignition risk they might cause. EPL also considers the potential consequences of an explosion. For zone 0/20, the equipment protection level required would be “a”; for zone 1/21, it would be “b”; and for zone 2/22, the level would be “c”.

Select the motor type according to the zone and category/EPL

Standard IEC 60079-0 EN 60079-0	Zone according to IEC 60079-10-x EN 60079-10-x		Main motor protection types	In addition for ATEX Directive 2014/34/EU (previously 94/9/EC)		
Group	EPL	Protection level	Zones	Equipment group	Equipment category	
I (Mines)	Ma	Very high	The zone classification is not used in mines.	Ex db	I (Mines)	M1
	Mb	High				M2
II (Gas)	Ga	Very high	0	No electric motors allowed	II (Surface)	1G
	Gb	High	1	Ex db, Ex db eb, Ex pxb, Ex eb		2G
	Gc	Enhanced	2	Ex pzc, Ex ec		3G
III (Dust)	Da	Very high	20	No electric motors allowed		1D
	Db	High	21	Ex tb IP6X		2D
	Dc	Enhanced	22	Ex tc IP6X/IP5X		3D

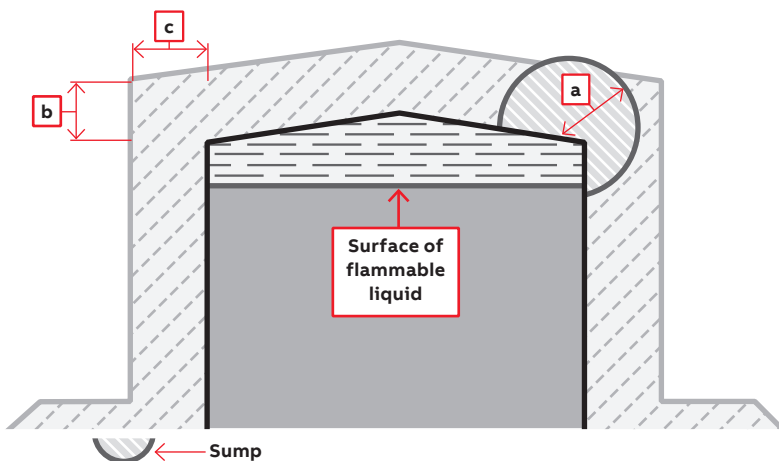
An example of zone definitions: storage tank



-  Zone 0
-  Zone 1
-  Zone 2

Zone distances are determined based on the risk assessment.

- a = Distance from vent opening
- b = Distance from the roof
- c = Horizontal distance from the tank

Certification markings



Example of a flameproof motor according to IECEx and ATEX

Equipment protection marking according to IEC and EN standards

Ex db IIC T4 Gb

Protection type Ex d (flameproof) with protection level b

Equipment group II (gas) and subdivision C (e.g. hydrogen)

Temperature Class T4 = max. permitted 135 °C

Equipment protection level = level b (high) for gas applications

Complementary marking according to ATEX directive

CE 0081 Ex II 2G

CE marking
ID of the notified body responsible for the approval

European Commission mark for Ex products

Equipment group: II for surface industry

Equipment category: 2G for gas environment demanding a high level of protection

Voltage and frequency

—
01 Voltage and
frequency
deviation in zones
A and B.

The table values for output, speed, efficiency, power factor, starting torque and starting current apply at the rated voltage and frequency.

Combinations of voltage variation and frequency variation are classified as being either zone A or zone B.

A motor is capable of operating continuously within zone A, but need not comply fully with its performance at rated voltage and frequency, and may exhibit some deviations. Temperature rises may be higher than at rated voltage and frequency.

A motor is capable of operating within zone B, but may exhibit greater deviations from its performance at rated voltage and frequency than in zone A. Temperature rises may be higher than at rated voltage and frequency, and most likely will be higher than those in zone A. Extended operation at the perimeter of zone B is not recommended.

If the motor is subject to continuous voltage variations of +/- 10% this should be taken into consideration in the design. The permitted combinations of voltage and frequency tolerances are specified in IEC60034-1.

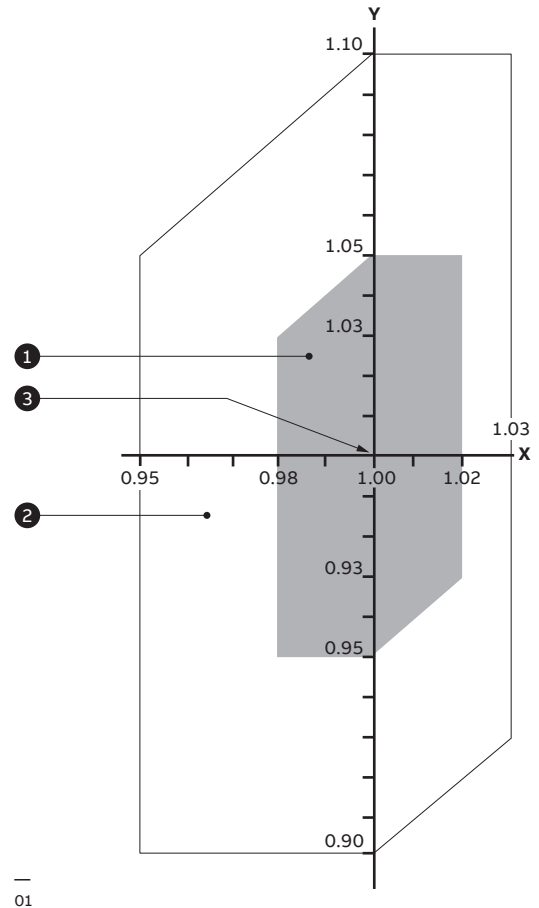

—
01

Key

X axis Frequency p.u.

Y axis Voltage p.u.

① Zone A

② Zone B (outside zone A)

③ Rating point



Range and Scope

—
01 Flameproof motor,
type AMD R

—
02 Flameproof motor,
type AMD T

ABB's engineered motors are tailor-made to meet customers' needs. All ABB engineered motors are configured and optimized individually for each order and application. Please contact ABB for further information. This catalogue contains information about ABB flameproof squirrel cage induction motors (type AMD), high voltage, output range from 160 to 7500 kW at 50 Hz and from 250 to 6900 HP at 60 Hz, with synchronous speed up to 3600 rpm. AMD motors can be used for standard and special applications. They can also operate with variable speed drives or used as induction generators. The mounting can be horizontal or vertical and the standard shaft heights are 355, 400, 450, 500, 560, 630, 710 and 900 mm.

The motors are available with the following cooling methods and degree of protection IC411, IP55 and IC511, IP55. According to NEMA MG1 the correspondent designation is TEFC and TEAAC. As option, forced cooling IC416 and IC516 and protection up to IP66 are available. The motors are normally designed for continuous operation at rated output (duty type S1 according to standards IEC 60034-1). Motors can also be quoted for other duty cycles. References about AMD main characteristics are summarized in table 1 and 2.

—
01

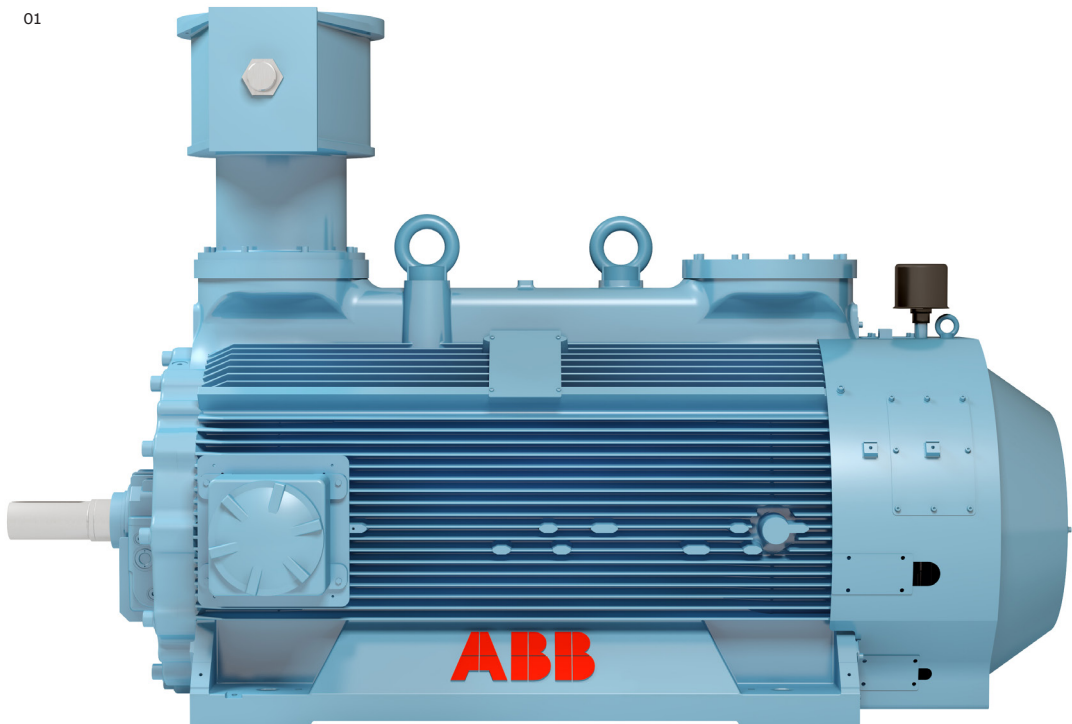

—
02**Table 1: Rib cooled motors, type AMD R**

Output power	100 to 1,600 kW
Frame size	355 to 500
Number of poles	2 to 18
Voltage	Up to 11 kV
Frequency	50/60 Hz, VSD
Cooling	IC411, IC416
Ambient temperature	-20 °C to 40 °C (as option down to -55 °C and up to 60 °C)
Protection	IP55 (as option up to IP66)
Enclosure material	Cast iron
Bearings	Antifriction or sleeve
Mounting	Horizontal or vertical
Ex protection types	Ex db, Ex db eb, Ex tb, Ex db I Mb
Gas/Dust group	I, IIB, IIC, IIIC
Temperature Class	T3, T4, T5
Standards	IEC, EN, NEMA electrical

Table 2: Tube cooled motors, type AMD T

Output power	700 to 7,500 kW
Frame size	500 to 900
Number of poles	2 to 18
Voltage	Up to 11 kV
Frequency	50/60 Hz, VSD
Cooling	IC511, IC516
Ambient temperature	-20 °C to 40 °C (as option down to -50 °C and up to 60 °C)
Protection	IP55
Enclosure material	Welded steel
Bearings	Antifriction or sleeve
Mounting	Horizontal or vertical
Ex protection types	Ex db, Ex db eb
Gas/Dust group	IIB
Temperature Class	T3, T4
Standards	IEC, EN, NEMA electrical







Certificates

ABB flameproof motors are certified according to ATEX Directive 94/9/EC – based on EN standard – for European market and according to IEC standard extra European market, if not differently required/specified.





On request, other local certifications are available.

In the tables below it's possible to find all types of certifications available for HV flameproof motors for the moment.

AMD Rg 355-400-450-500

Certification scheme	Protection mode	Group	Category (only for ATEX)	Zone	Gas/Dust group	Temperature class	EPL	
ATEX		Ex db	II	2G	Zone 1	IIB / IIC	T1 to T5	Gb
		Ex db eb						
		Ex tb	I	M2	-	-	-	Mb
IECEX		Ex db	II	-	Zone 1	IIB / IIC	T1 to T5	Gb
		Ex db eb						
		Ex tb	I	-	-	-	Mb	
EAC Ex		1 Ex db	II	-	Zone 1	IIB / IIC	T1 to T5	Gb X
		1 Ex db e						
		Ex tb	I	-	-	-	Mb X	
CCC Ex		Ex d	II	-	Zone 1	IIB / IIC	T1 to T5	Gb
		Ex d e						
		Ex tD	I	-	-	-	Mb X	
CCoE		Ex db	II	-	Zone 1	IIB / IIC	T1 to T5	Gb
		Ex db eb						
		Ex tb	I	-	-	-	Mb	
INMETRO		Ex db	II	-	Zone 1	IIB / IIC	T1 to T5	Gb
		Ex db eb						
		Ex tb	I	-	-	-	Mb	

AMD T 500-560-630-710-900

Certification scheme	Protection mode	Group	Category (only for ATEX)	Zone	Gas/Dust group	Temperature class	EPL	
ATEX		Ex db	II	2G	Zone 1	IIB/IIC	T1 to T4	Gb
		Ex db eb						
		Ex tb	I	M2	-	-	-	Mb
IECEX		Ex db	II	-	Zone 1	IIB/IIC	T1 to T4	Gb
		Ex db eb						
		Ex tb	I	-	-	-	Mb	
EAC Ex		1 Ex db	II	-	Zone 1	IIB/IIC	T1 to T4	Gb X
		1 Ex db e						
CCC Ex		Ex d	II	-	Zone 1	IIB / IIC	T1 to T4	Gb
		Ex d e						
CCoE		Ex db	II	-	Zone 1	IIB/IIC	T1 to T5	Gb
		Ex db eb						



ØYEVASK
EYE-BATH

MDEA
CORROSIVE

Stator and Insulation

Stator

The stator core is welded and machined to form a solid and compact unit that retains its rigidity throughout the life of the motor. When present, radial air ducts ensure uniform and efficient cooling.

When completely wound and connected, the stator is vacuum pressure impregnated and cured with ABB's Micadur® Compact Industry insulation system, a specially formulated epoxy resin used by ABB to insulate all its rotating electrical machines over the past 30 years. Micadur ensures a sealed and homogeneous insulation system, resulting in low dielectric losses, high dielectric strength, excellent heat transfer and the elimination of hazardous internal partial discharges.

ABB uses class F insulation, which, with temperature rise B, is the most common requirement among industry today.

The use of class F insulation with class B temperature rise gives ABB products a 25 °C safety margin. This can be used to increase the loading for limited periods, to operate at higher ambient temperatures or altitudes, or with greater voltage and frequency tolerances. It can also be used to extend insulation life.

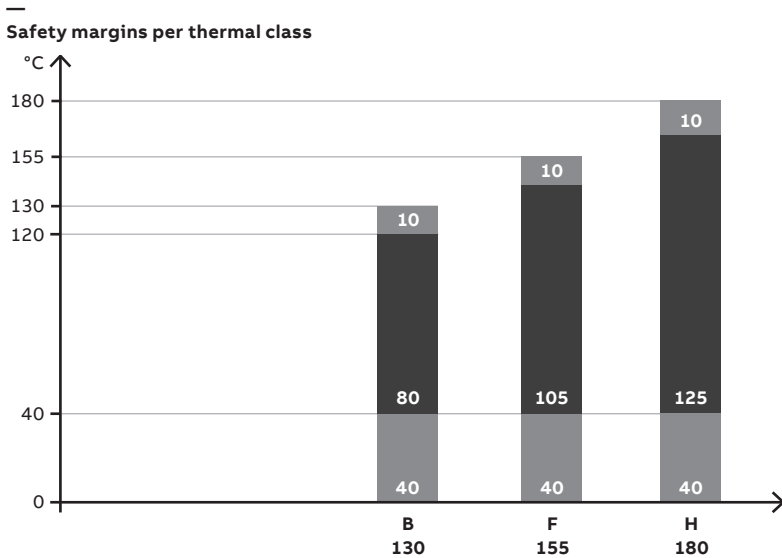

Thermal class 130 (B)

- Nominal ambient temperature 40 °C
- Max permissible temperature rise 80 K
- Hot spot temperature margin 10 K

Thermal class 155 (F)

- Nominal ambient temperature 40 °C
- Max permissible temperature rise 105 K
- Hot spot temperature margin 10 K

Thermal class 180 (H)

- Nominal ambient temperature 40 °C
- Max permissible temperature rise 125 K
- Hot spot temperature margin 10 K

Rotor and Vibrations

Rotor

The key to a long rotor operating life is minimal vibration. This is achieved through robust construction and careful balancing. ABB selects the shaft material according to the demands of the application and the ambient conditions in which the motor is to operate.

Squirrel cages are made of copper, copper alloy or aluminum, depending on the load and customer requirements. Additional stiffness is provided by fabricated rotor bars, which enable the motors to withstand long periods of heavy use. Aluminum bars and end rings are used to ensure optimal starting characteristics.

Once assembled each rotor is dynamically balanced at full operating speed in accordance with the ISO 1940-1 and ISO 11342 standards on mechanical vibration.

Vibration – Standard design

The standard motors manufactured according to IEC standard satisfy the Grade A vibration limits specified in IEC 60034-14. The maximum accepted values are shown in the table below.

Standard design unfiltered vibration limits

Poles	Speed (rpm)	Bearing housing vibration	Relative shaft vibration	Combined runout
2	1 800 < n ≤ 3600	2.3 mm/s rms	65 μm p-p	16 μm p-p
≥ 4	n ≤ 1800	2.3 mm/s rms	90 μm p-p	23 μm p-p

Optional design unfiltered vibration limits

Under request, motors can be manufactured to satisfy the Grade B vibration limits specified in IEC 60034-14. The maximum accepted values are modified as shown in the table below. Same table of above but with following values.

Poles	Speed (rpm)	Bearing housing vibration	Relative shaft vibration	Combined runout
2	1 800 < n ≤ 3600	1.8 mm/s rms	50 μm p-p	12.5 μm p-p
≥ 4	n ≤ 1800	1.8 mm/s rms	65 μm p-p	16 μm p-p

Antifriction bearing

Antifriction motors

The horizontal mounted motors up to size 630 (except 2 poles), are as standard, provided with deep groove ball bearings for grease lubrication; the size 710 and 900 is provided with rolling bearings for radial load and deep groove ball bearing on D side for rotor axial location. The N-end bearing is axially free to allow thermal elongation of the shaft; this bearing (if it is a deep groove type) is also spring loaded, so it reduces noise and vibration.

Vertical mounted motors are provided, as standard, with angular contact ball bearing on

N-end, carrying the rotor weight. On the D-end of the machine there is an axially free spring loaded deep groove ball bearing.

The standard degree of protection is IP55. Option up to IP66 is available as options for certain configurations.

Horizontal motors

Standard bearings for horizontal motors are listed in the following tables, and bearing constructions are shown on the drawings on page 25.

Standard bearings for AMD motors with ribs cooling circuit, IIB/IIC, cast iron frame for horizontal assembly

Frame size	Number of poles	D-end	N-end
355...R...g	2	6316	6316
355...R...g	4	6322	6316
400...R...g	2	6317	6317
400...R...g	4	6324	6319
450...R...g	2	6317	6317
450...R...g	4	6324	6324
500...R...g	2	6319	6319
500...R...g	4	6330	6330

Standard bearings for AMD motors with tubes cooling circuit for horizontal assembly

Frame size	Number of poles	Side	Frequency	
			50 Hz	60 Hz
500...T	2	DE	6317 - C3	●
		NDE	6317 - C3	●
500...T	≥4	DE	6324 - C3	
		NDE	6319 - C3	
560...T	2	DE	6319 - C3	●
		NDE	6319 - C3	●
560...T	≥4	DE	6326 - C3	
		NDE	6322 - C3	
630...T	2	DE	X	X
		NDE	X	X
630...T	≥4	DE	6330 - C3	
		NDE	6324 - C3	
710...T	2	DE	X	X
		NDE	X	X
710...T	≥4	DE	6034 - C3 NU1034 EC NU322 EC3	
		NDE		
900...T	4	DE	6044 - M1C3 NU1044 - M1C3	
		NDE	NU1044 - M1C3	
	≥6	DE	6048 - M1C3 NU1048 - M1C3	
		NDE	NU1048 - M1C3	

● = Not standard
X = Not available

—
Antifriction bearing arrangement ≤ 630 , 4 and more poles

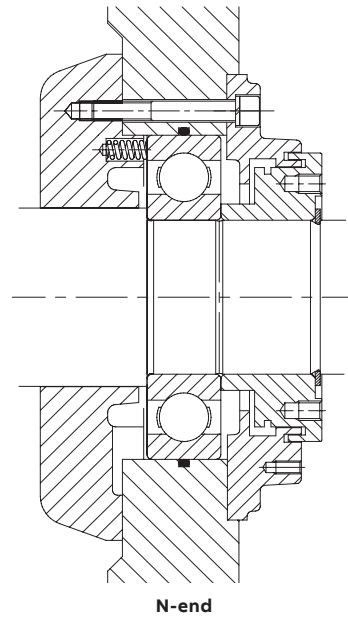
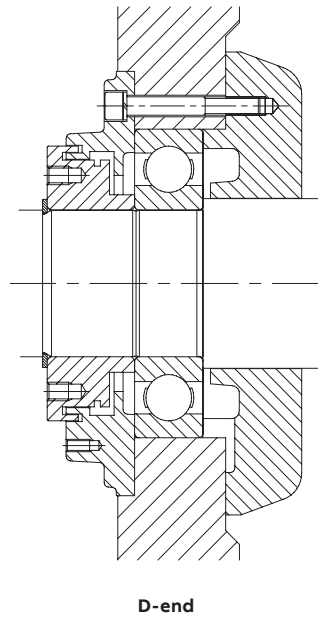

Some AMD with a rolling bearing on N side are not spring preloaded.

On belt drive applications, with high radial forces, the motors can be delivered with a roller (NU) bearing on D-end. The cylindrical roller bearings have a greater radial load capacity than the above mentioned deep groove ball bearings.

When NU-bearings are used, the rotor will always be transport locked with necessary warning labels on the motor.

All the bearings are chosen with C3 internal tolerance; no difference in bearing arrangement between 50 and 60 Hz motors.

—
Antifriction bearing arrangement 710, 4 and more poles

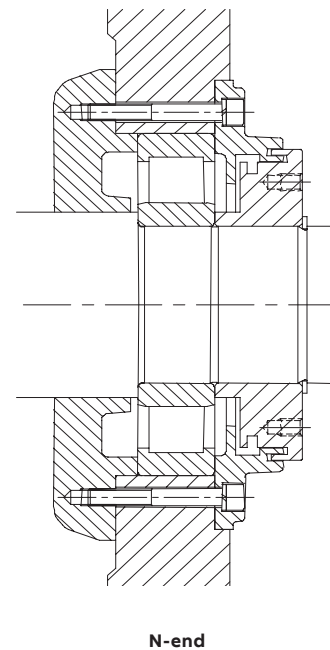
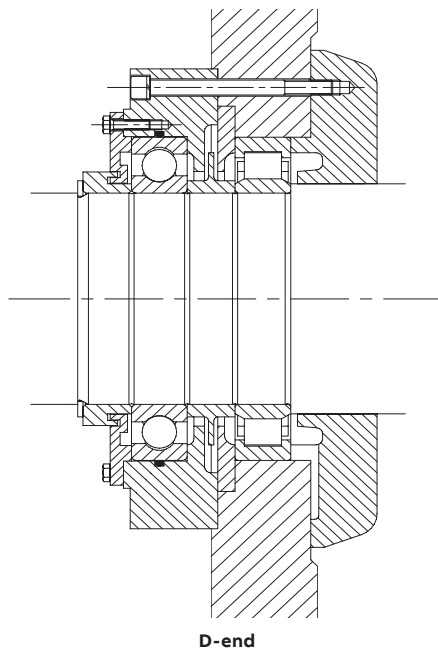

Vertical motors

Standard bearings for vertical motors are listed in table below.

The bearing constructions are shown on the drawings on the next pages.

All the bearings are with C3 internal tolerance; no difference in bearing arrangement between 50 and 60 Hz.

Standard bearings for AMD motors with ribs cooling circuit, IIB/IIC, cast iron frame for vertical assembly

Frame size	Number of poles	D-end	N-end
355...R...g	2	6316	7213
355...R...g	4	6322	6316
400...R...g	2	6317	7217
400...R...g	4	6324	6319
450...R...g	2	6317	7317
450...R...g	4	6324	7324
500...R...g	4	6330	7330

Standard bearings for AMD motors with tube cooling circuit and vertical assembly

Frame size	Number of poles	D-end	N-end
500...T	4	6024 – C3	7319
560...T	4	6026 – C3	7322
630...T	4	6030 – C3	7324
710...T	4	6034 – C3	7330
900...T	6	6044 – C3	2x7334 (DT-Tandem)

—
Standard NDE side bearing arrangement with single row angular contact ball bearing

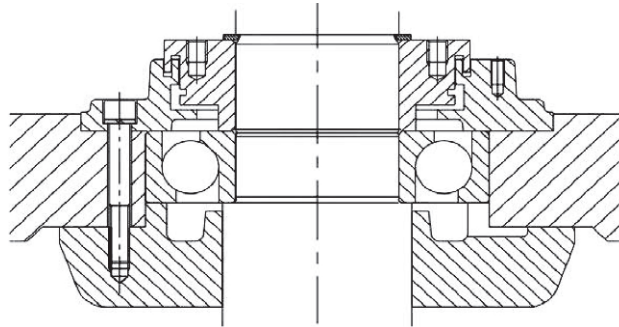

—
Standard NDE side bearing “DT-Tandem” arrangement with angular contact ball bearing for AMD 900...T motors

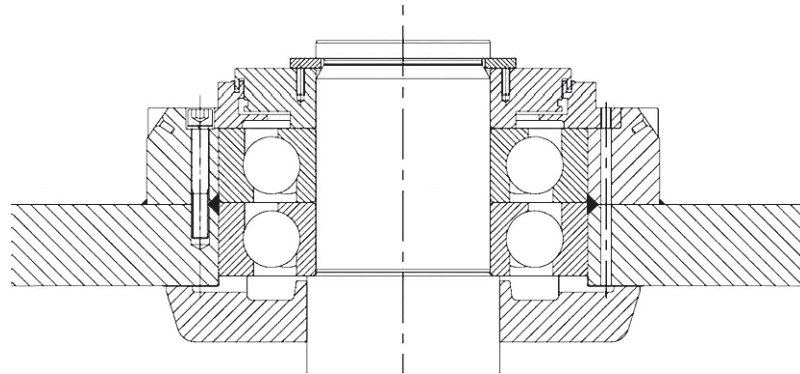

Special constructions for high axial loads are available upon request; in such cases the correct bearing arrangement must be chosen case by case in respect of maximum load and direction, speed, requested bearing life, etc.

—
Standard DE side bearing arrangement with axially free preloaded deep groove ball bearing

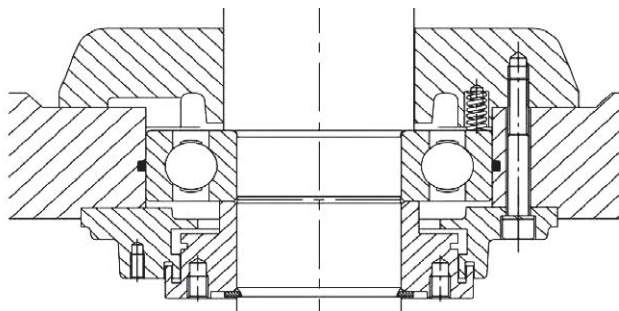

Bearing rating life

L_{10h} in excess of 100000 h. It could be lower for bigger machines with low pole number.

The lifetime is calculated in accordance with ISO R 281-1 and it is communicated with the quotation. The basic rated lifetime L_{10h} is the number of hours at rated bearing load and speed that 90% in a group of identical bearings will complete or exceed before the first evidence of failure.

Lubrication

The motors are equipped with grease nipples at both ends to lubricate the bearing. Lubrication must be performed while the machine is rotating as specified in maintenance instructions delivered with the machine. The grease, which is exhausted and in excess, is automatically removed by the grease valve through the outer bearing cover.

In case of lower bearing lubrication frequency, automatic lubricators are available.

Lubrication frequency, in hours, for operation at 50 Hz and horizontal assembly, for AMD motors with ribs cooling circuit, IIB/IIC, cast iron frame.

Frame size	Number of poles						Grease quantity (g) for each bearing	
	2	4	6	8	10	12-n	2 poles	4-n poles
355...R...g	3100	8100	8800	–	–	–	33	60
400...R...g	2500	7000	8800	8800	–	–	41	60
450...R...g	1600	3000	5000	6500	7500	8000	40	75
500...R...g	1800	4000	8000	8000	8000	8000	45	104

Lubrication frequency, in hours, for operation at 60 Hz and horizontal assembly, for AMD motors with ribs cooling circuit, IIB/IIC, cast iron frame.

Frame size	Number of poles						Grease quantity (g) for each bearing	
	2	4	6	8	10	12-n	2 poles	4-n poles
355...R...g	1300	6600	7300	–	–	–	33	60
400...R...g	1200	5000	7300	7300	–	–	41	60
450...R...g	1000	2100	4100	5700	6900	7900	40	75
500...R...g	NA	2700	6000	8000	8000	8000	45	104

Lubrication frequency, in hours, for operation at 50 Hz and vertical assembly, for AMD motors with ribs cooling circuit, IIB/IIC, cast iron frame.

Frame size	Number of poles						Grease quantity (g) for each bearing	
	2	4	6	8	10	12-n	2 poles	4-n poles
355...R...g	1500	4000	5500	–	–	–	33	60
400...R...g	1250	3500	5000	–	–	–	21	71.5
450...R...g	800	1500	2500	3300	3900	4400	40	75
500...R...g	–	2100	4000	5600	6800	7750	–	100

—
Lubrication frequency, in hours, for operation at 50 Hz and vertical assembly, for AMD motors with ribs cooling circuit, IIB/IIC, cast iron frame.

Frame size	Number of poles						Grease quantity (g) for each bearing	
	2	4	6	8	10	12-n	2 poles	4-n poles
355...R...g	600	3300	4600	–	–	–	33	60
400...R...g	600	2500	4100	–	–	–	21	71.5
450...R...g	510	1100	2000	2800	3400	3900	40	75
500...R...g	–	1400	3070	4600	5800	6800	–	100

—
Lubrication frequency, in hours, for operation at 50 Hz and horizontal assembly, for AMD motors with tubes cooling circuit, IIB.

Frame size	Number of poles						Grease quantity (g) for each bearing	
	2	4	6	8	10	12-n	2 poles	4-n poles
500..T	3000	6000	8800	8800	8800	8800	35	70
560..T	2500	5000	8800	8800	8800	8800	45	80
630..T	–	4000	8000	8800	8800	8800	–	90
710..T	–	1900	4000	6000	7000	8800	–	55
900..T	–	600	750	1550	1850	2350	–	100
Size	Number of poles						Grease quantity (g) for each bearing	
		14		16		18		6-n poles
900..T		2850		3250		3450		100

—
Lubrication frequency, in hours, for operation at 60 Hz and horizontal assembly, for AMD motors with tubes cooling circuit, IIB.

Frame size	Number of poles						Grease quantity (g) for each bearing	
	2	4	6	8	10	12-n	2 poles	4-n poles
500..T	2000	4000	8000	8800	8800	8800	35	70
560..T	–	3500	7000	8800	8800	8800	–	80
630..T	–	2500	6000	8800	8800	8800	–	90
710..T	–	1000	2500	4500	5000	6000	–	55
900..T	–	300	450	1000	1400	1800	–	100
Frame size	Number of poles						Grease quantity (g) for each bearing	
		14		16		18		6-n poles
900..T		2300		2500		3000		100

Lubrication frequency, in hours, for operation at 50 Hz and vertical assembly, for AMD motors with tubes cooling circuit, IIB.

Frame size	Number of poles						Grease quantity (g) for each bearing	
	2	4	6	8	10	12-n	2 poles	4-n poles
500..T	–	4000	6000	7500	8500	8800	–	70
560..T	–	3500	5500	7000	8000	8800	–	80
630..T	–	3000	5000	6500	7500	8500	–	90
710..T	–	2000	4000	5500	7000	8000	–	55
900..T	–	–	2400	3600	4600	5400	–	–
Size	Number of poles			Grease quantity (g) for each bearing				
	14	16	18	6-18 poles, DE side		6-18 poles, NDE side		
900..T	6000	6500	6800	100		2x130		

Lubrication frequency, in hours, for operation at 60 Hz and vertical assembly, for AMD motors with tubes cooling circuit, IIB.

Frame size	Number of poles						Grease quantity (g) for each bearing	
	2	4	6	8	10	12-n	2 poles	4-n poles
500..T	–	3000	5000	6500	7500	8500	–	70
560..T	–	2500	4500	6000	7000	8000	–	80
630..T	–	2000	4000	5500	6500	7500	–	90
710..T	–	1500	3000	4500	6000	7000	–	55
900..T	–	–	1800	2800	3800	4600	–	–
Size	Number of poles			Grease quantity (g) for each bearing				
	14	16	18	6-18 poles, DE side		6-18 poles, NDE side		
900..T	5300	5800	6200	100		2x130		

The calculation had been performed considering an ambient temperature of 40 °C; if the rated temperature is different, the given values can be changed consequently; the lubricating intervals must be halved for every 15 °C over the referring value. The lubricating interval must be not higher than one time at year. Due to the reduced air gap existing between the static and rotating parts of the flame arrestors, for explosion proved motor

the max allowable bearing wear is smaller than for normal motors; that is the reason why the rated bearing life and lubricating intervals are normally reduced.

Specific indications about lubricating intervals, type/quantity of grease and bearing type are provided on a dedicated lubricating plate for each bearing on every motor.

Sleeve bearing

Sleeve bearings used in AMD machines are side flange bearings. The bearing in the D-end is the guide bearing and gives the shaft axial position, it is only suitable to withstand limited and non-continuous axial forces. The shaft thermal elongation will be towards the N-end, where an axially free bearing is provided.

All sleeve bearings are fitted with an oil ring for self-lubrication and the bearing shells are prepared for external oil supply. In some cases external driven lubrication is required.

- 1 Top half of the housing
- 2 Positioning pin hole
- 3 Positioning pin
- 4 Connection hole for the thrust part oil supply
- 5 Top sight glass
- 6 Eye bolt
- 7 Screw
- 8 Screw
- 9 Tap hole
- 10 Flame arrestor (schematic)
- 11 Top half of the shell
- 12 Split line screw
- 13 Bottom half of the shell
- 14 Spherical seating
- 15 Engraved number
- 16 Recess
- 17 Tap hole
- 18 Screw
- 19 Split line screw
- 20 Engraved numbers
- 22 Connection hole for temp. measurement of the journal part
- 23 Oil inlet connection hole
- 24 Connection hole for the oil sump temp. measurement
- 25 (Water cooling – special design)
- 26 (Oil cooler special design)
- 27 Oil drain plug
- 28 Metal tabs
- 29 Oil outlet connection hole
- 30 Oil outlet pipe with special nut and lead sealing ring
- 31 Marking

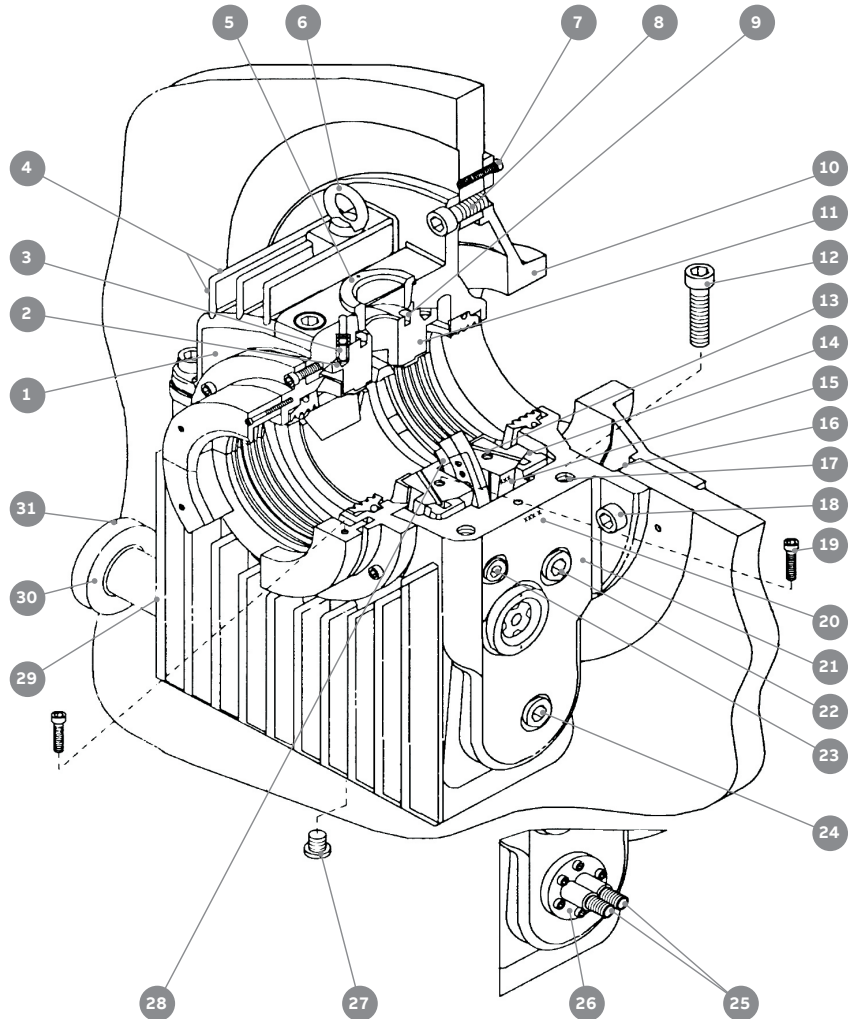

Lubrication

Standard sleeve bearings for AMD machines and respective lubrication methods are listed in Table 1 and 2a/b.

Note! The mentioned types of lubrication are valid for ambient temperature of 40 °C; for ambient temperatures over 40 °C, please refer to the technical support.

Table 1: Sleeve bearings for rib cooled, cast iron frame, AMD machines

Frame size	Poles	Frequency	D-end	N-end	Lubrication
355...Rg	2	50-60	EFNLB 9-80	EFNLQ 9-80	Self lubrication
355...Rg	≥4	50-60	EFNLB 9-90	EFNLQ 9-80	Self lubrication
400...Rg	2	50-60	EFNLB 9-80	EFNLQ 9-80	Self lubrication
400...Rg	≥4	50-60	EFNLB 11-125	EFNLQ 9-100	Self lubrication
450...Rg	2	50-60	EFNLK 9-90	EFNLQ 9-90	Self lubrication
450...Rg	4	50-60	EFNLB 9-90	EFNLQ 9-90	Self lubrication
450...Rg	>4	50-60	EFNLB 9-100	EFNLQ 9-100	Self lubrication
500...Rg	2	50	EFNLK 9-90	EFNLQ 9-90	Self lubrication
500...Rg	2	60	EFZLK 9-90	EFZLQ 9-90	Forced lubrication
500...Rg	4	50-60	EFNLB 14-125	EFNLQ 11-125	Self lubrication

Table 2a: Sleeve bearings for tubes cooled AMD machines

Frame size	Poles	D-end	N-end	Lubrication
500...T	2	EFNLB 9-80	EFNLQ 9-80	Self lubrication
500...T	4	EFNLB 11-110	EFNLQ 9-100	Self lubrication
560...T	2	EFNLB 9-90	EFNLQ 9-90	Self lubrication
560...T	≥4	EFNLB 11-125	EFNLQ 9-100	Self lubrication
630M...T	2	EFNLB 9-90	EFNLQ 9-90	Self lubrication
630L...T	2	EFZLB 9-100	EFZLQ 9-100	Oil circulation
630...T	≥4	EFNLB 14-140	EFNLQ 11-125	Self lubrication
710...T	2	EFZLB 11-125	EFZLQ 11-125	Oil circulation
710...T	4...6	EFZLB 14-160	EFZLQ 14-160	Oil circulation
710...T	≥8	EFNLB 14-160	EFNLQ 14-160	Self lubrication
710X...T	≥4	EFZLB 14-180	EFZLQ 14-180	Oil circulation

In the following table 2b related to AMD 900, white color row identifies standard sleeve bearing lubrication and grey one – as optional lubrication.

Table 2b: Sleeve bearings for tubes cooled AMD machines

Motor type	Pole number	Frequency (Hz)	DE-Bearing DIN type designation	NDE-Bearing DIN type designation	Standard (optional) type of lubrication
AMDT 900	2	50	EFZLB 14-140	EFZLQ 14-140	Forced
	4	50	EFZLB 18-200	EFZLQ 18-200	Forced
		60	EFZLB 18-200	EFZLQ 18-200	Forced
	6	50	EFZLB 18-225	EFZLQ 18-225	Forced
		60	EFZLB 18-225	EFZLQ 18-225	Forced
	8	50	EFZLB 18-225	EFZLQ 18-225	Forced
		60	EFZLB 18-225	EFZLQ 18-225	Forced
	10	50	EFZLB 18-225	EFZLQ 18-225	Self
		50	EFZLB 18-225	EFZLQ 18-225	Forced
		60	EFZLB 18-225	EFZLQ 18-225	Forced
		50/60	EFZLB 18-225	EFZLQ 18-225	Self
	12	50/60	EFZLB 18-225	EFZLQ 18-225	Forced
		50/60	EFZLB 18-225	EFZLQ 18-225	Self
	14	50/60	EFZLB 18-225	EFZLQ 18-225	Forced
		50/60	EFZLB 18-225	EFZLQ 18-225	Self
	16	50/60	EFZLB 18-225	EFZLQ 18-225	Forced
		50/60	EFZLB 18-225	EFZLQ 18-225	Self
	18	50/60	EFZLB 18-225	EFZLQ 18-225	Forced
50/60		EFZLB 18-225	EFZLQ 18-225	Self	

Mineral oils are normally used as standard for AMD machines bearings. The oil used, must have a viscosity value as defined in ISO 3448 class or SSU.

Synthetic oils type and usage must be approved by bearing manufacturer because it can be not completely compatible with the non-metallic bearing sealings. Synthetic oils are better than mineral oils when ambient temperature is very cold or warm.

Permissible forces

Radial forces

If the motor has external radial loads, the standard bearing solutions must be verified by the ABB technical office. If oversized bearings are needed, motor certification shall be modified.

Axial forces

The sleeve bearings can withstand very limited axial forces coming from operating machine or due to particular installation.

Please contact ABB to evaluate best technical solution in case motor is subject to axial forces.



Terminal boxes for flameproof motors

AMD motors are by default equipped with flameproof main terminal boxes. Like motor, terminal boxes are design to withstand an internal explosion and to prevent its propagation to external, where explosive atmosphere may be present.

On request AMD motors can be equipped with increase safety terminal boxes (Ex eb). This type of protection is based on avoiding excessive temperatures, arcs and sparks inside terminal boxes. This is achieved with increased clearance and creepage distance between terminals and metal parts, special insulators and gasket materials, minimum mechanical protection degree, non loosening terminals, etc.

ABB can provide different solution for Ex eb main terminal boxes:

- Standard Ex eb MTB
- Ex eb phase insulated (Raychem system): terminals are insulated with heat shrink tubings. Solid insulations prevent electrical failure within the terminal box.
- Ex eb phase insulated (Elastimold system): terminals are insulated with plugged connectors which are easily removable without damaging the insulation. Solid insulations prevent electrical failure within the terminal box.

- Ex eb phase separated: terminals are separated using insulated barriers which separate phases and prevent any electrical breakdown to an earth fault.
- Ex eb phase segregated: terminals are segregated in separate chambers, one for each phase. Earthed metallic barriers forms a completely distinct individual phase compartment so to prevent any electrical breakdown to an earth fault.

According to EN and IEC standards maximum voltage for Ex e execution is 11 kV including positive variations.

Terminal boxes are certified according to IEC/EN 60079-0, IEC/EN 60079-1, IEC/EN 60079-7 standards mandatory for International/ European market with additional marking:

- Installation group: II (surface plants)
- Equipment category: 2 (for a high protection level)
- Atmosphere explosive: G (explosive gas)

Surface treatment

The surface treatment categorization of ABB motors is based on the ISO 12944 standard. ISO 12994-5 divides paint system durability into three categories: low (L), medium (M), and high (H). Low durability corresponds to a lifetime up to 7 years, medium to 7 – 15 years, high durability 15-25 years, and very high over 25 years.

The durability range is not a guaranteed lifetime. Its purpose is to help the owner of the motor plan for appropriate maintenance intervals. More frequent maintenance may be required because of fading, chalking, contamination, wear and tear, or for other reasons.

ABB's standard surface treatment is corrosivity category C3, durability range H (which equals to medium corrosivity and high durability). Special surface treatment is available in corrosivity categories C4, C5 and CX. In addition, surface treatment according to the NORSOK M-501 standard for offshore environments is available as an option.

The standard ABB paint color for motors is Munsell blue 8B 4.5/3.25. Different color can be provided upon request.

Atmospheric corrosivity categories and recommended environments

Corrosivity category	Outdoor atmospheres	Indoor atmospheres	Use in ABB motors
C1, very low	Not used	Heated buildings with clean atmospheres.	Not available
C2, low	Atmospheres with low level pollution, mostly rural areas.	Unheated buildings where condensation may occur, such as depots and sports halls.	Not available
C3, medium	Urban and industrial atmospheres, moderate sulfur dioxide pollution. Coastal areas with low salinity.	Production rooms with high humidity and some air pollution; food processing plants, laundries, breweries, dairies.	Standard treatment
C4, high	Industrial areas and coastal areas with moderate salinity.	Chemical plants, swimming pools, coastal ship- and boatyards.	Optional treatment
C5, very high	Industrial areas with high humidity and aggressive atmosphere, and coastal areas with high salinity.	Buildings or areas with nearly permanent condensation and high pollution.	Optional treatment
CX, extreme	Offshore areas with high salinity and industrial areas with extreme humidity, aggressive atmosphere and subtropical/ tropical atmosphere.	Industrial areas with extreme humidity and aggressive atmospheres.	Optional treatment

Mounting

Standard mounting arrangements for AMD motors

—
01
Code I: IM B3
Code II: IM 1001
Standard floor
mounting, feet
facing downwards
(horizontal foot
mounted)

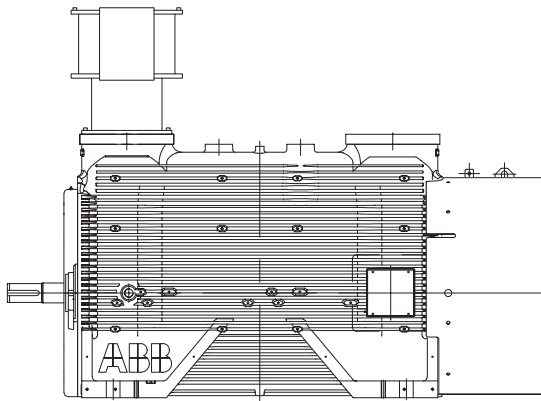

01

—
02
Code I: IM V1
Code II: IM 3011
Flanged D-end shield
and free shaft end
facing downwards
(vertical solid shaft,
flange mounted)

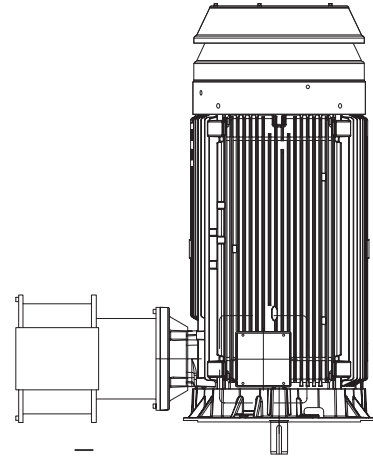

02

—
03
Code I: IM V1
Code II: IM 4011
Flange and free
shaft end facing
downwards
(vertical solid
shaft, flange
mounted)

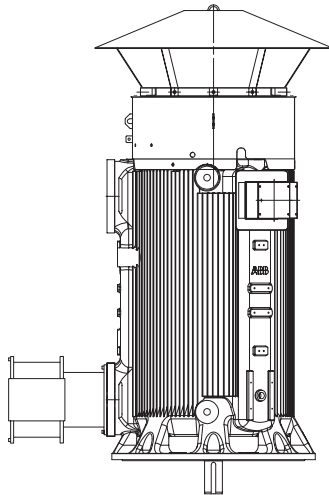

03

—
04
Code I: IM B35
Code II: IM 2001
Standard floor
mounting, feet facing
downwards, with
additional mounting
on D-end side flange

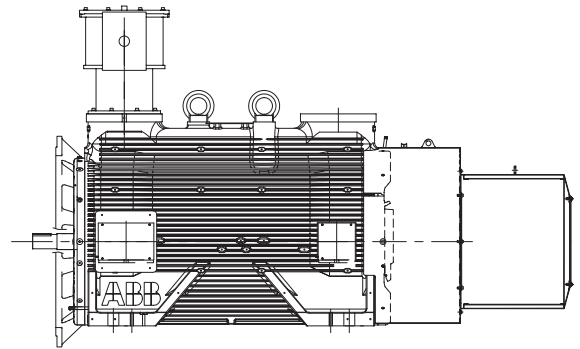

04

Cooling

Designation system concerning methods of cooling refers to standard IEC 60034-6. Standard cooling method is IC411. For further information please see the variant code section of each motor type for availability of other cooling methods.

Explanation of the product code					
International Cooling	Circuit arrangement	Primary coolant	Method of movement of primary coolant	Secondary coolant	Method of movement of secondary coolant
IC	4	(A)	1	(A)	5
	1	2	3	4	5

Position 1

- 0: Free circulation (open circuit)
- 4: Frame surface cooled
- 5: Integral heat exchanger (using surrounding medium)

Position 2

- A: For air (omitted for simplified designation)

Position 3

- 0: Free convection
- 1: Self-circulation
- 6: Machine-mounted independent component

Position 4

- A: For air (omitted for simplified designation)

Position 5

- 0: Free convection
- 1: Self-circulation
- 6: Machine-mounted independent component

Degrees of protection: IP code and resistance to impact

Classification for degrees of protection (IP code) provided by enclosures of rotating machines are defined in standards IEC 60034-5 or EN 60529.

IP protection

Protection of persons against getting in contact with (or approaching) live parts and against contact with moving parts inside the enclosure. Also protection of the machine against ingress of solid foreign objects. Protection of machines against the harmful effects due to the ingress of water.

Explanation of the IP code		
Ingress protection	Degree of protection to persons and to parts of the motors inside the enclosure	Degree of protection provided by the enclosure with respect to harmful effects due to ingress of water
IP	5	5
	1	2

Position 1

2:	Motors protected against solid objects greater than 12 mm
4:	Motors protected against solid objects greater than 1 mm
5:	Dust-protected motors
6:	Dust-tight motors

Position 2

3:	Motors protected against spraying water
4:	Motors protected against splashing water
5:	Motors protected against water jets
6:	Motors protected against heavy seas

Following IEC/EN 60079-0 non-metallic parts of enclosures in motors for explosive atmospheres must be thermal endurance tested for the temperature range the motors are designed for. Non-metallic parts are, for instance, rubber seals and gaskets. Thermal endurance tests and impact tests are carried out before the ingress protection test. This ensures that the motors meet the ingress protection level also after been put in service.

Resistance to impact

ABB's motors for explosive atmospheres have been tested for resistance to impact as described in IEC/EN 60079-0. The more demanding high risk of mechanical danger limits have been used as qualification criteria. Impact energy strength is 20J for both enclosure and fan cover, making AMD motors suitable for mine operation.

Additional options

Thanks to ABB long experience in Chemical and Oil & Gas segment, AMD motors are broadly accepted by end users and can meet, on request, the main customer specifications:

- **Shell DEP**
- **API 541**
- **PETRONAS**
- **Aramco**
- **ExxonMobil**
- **Total**
- **BP**
- **Repsol**
- **Borealis**
- **S-704 (JIP 33)**

Accessories

ABB explosion proof motors can be equipped with many accessories to fulfill all customer requests:

- Auxiliary Terminal Boxes
- Bearings Automatic Lubricators
- Breather and Drain Plug
- Cable Glands
- Circuit Breakers (MCB or other)
- Conduits
- Current Transformer
- Jacking Oil
- Measuring Transducer
- Non-losing terminals
- Oil Level Monitor
- Oil Sump Heater
- Partial Discharge Measurement
- Pulse Encoder
- Rotor Position sensor
- Rotor Telemetry (Ground Fault or other)
- Rogowski Coil (in MTB)
- RTD's surge arresters
- RTD's Transmitters
- Sealed multi-wires bushing
- Space Heaters
- Speed Switch
- Star Point Terminal Box
- Surge Arrester (in MTB)
- Surge Capacitor (in MTB)
- Terminal Block
- Thermometer
- Vibration monitoring
- Voltage Transformer
- Bushing Insulator
- Other on request

Rating plates

Rating plates for HV motor according to IEC

ABB		ABB Oy <small>Made in Hiomotte 13, 00380 Helsinki, Finland</small>	
Type	AMD 450 M2R BABgFH		No 4673615
Year	2019	Phases 3~	Duty S1
Connection	D	Insul.cl. F	Weight 6700 kg
IP	55	IC 416	IM 2011
S1, CONVERTER SUPPLY, ACS 2000sin			
Output	267	- 800	kW
Voltage	147	- 440	V
Current	1182	- 1182	A
Power factor	0.91	- 0.91	PF
Frequency	20.2	- 60.2	Hz
Speed	1200	- 3600	rpm
Ambient -25/+50 °C			
Use screws quality 8.8 ISO R 898 / I-II			
Ex db IIB T3 Gb			
CERTIFICATE No. IECEx TPS 17.0005X			

Rating plates for HV motor according to EN

ABB		ABB Oy <small>Made in Hiomotte 13, 00380 Helsinki, Finland</small>	
Type	AMD 450 M2R BABgFH		No 4673615
Year	2019	Phases 3~	Duty S1
Connection	D	Insul.cl. F	Weight 6700 kg
IP	55	IC 416	IM 2011
S1, CONVERTER SUPPLY, ACS 2000sin			
Output	267	- 800	kW
Voltage	147	- 440	V
Current	1182	- 1182	A
Power factor	0.91	- 0.91	PF
Frequency	20.2	- 60.2	Hz
Speed	1200	- 3600	rpm
Ambient -25/+50 °C			
Use screws quality 8.8 ISO R 898 / I-II			
CE 0537 II 2G Ex db IIB T3 Gb			
CERTIFICATE No. TÜV IT 19 ATEX 042X			

ABB		ABB Oy <small>Made in Hiomotte 13, 00380 Helsinki, Finland</small>	
Type	AMD 350 L2R VABgH		No 4673615
Year	2019	Phases 3~	Output 185 kW
Duty	S1		Voltage 3300 V
Connection	Y		Frequency 50 Hz
Insul.cl.	F		Speed 2979 rpm
Weight	2350 kg		Current 37 A
IP	55	Power factor 0.92	
IC	411	IM 3011	Ambient Temp:-25/+50 °C
Use screws quality 8.8 ISO R 898 / I-II			
Ex db IIB T3 Gb			
CERTIFICATE No. IECEx LCI 08.0001X			

ABB		ABB Oy <small>Made in Hiomotte 13, 00380 Helsinki, Finland</small>	
Type	AMD 350 L2R VABgH		No 4673615
Year	2019	Phases 3~	Output 185 kW
Duty	S1		Voltage 3300 V
Connection	Y		Frequency 50 Hz
Insul.cl.	F		Speed 2979 rpm
Weight	2350 kg		Current 37 A
IP	55	Power factor 0.92	
IC	411	IM 3011	Ambient Temp:-25/+50 °C
Use screws quality 8.8 ISO R 898 / I-II			
CE 0537 II 2G Ex db IIB T3 Gb			
CERTIFICATE No. LCIE 03 ATEX 6056X			

IEC recommends to state the following on a rating plate:

- Name of the manufacturer
- Manufacturer's serial number or identification number
- Identification of manufacturing year
 - On rating plate
 - Separate data sheet together with the motor (note in the box)
- Manufacturer's machine code
- Number of phases
- Degrees of protection according to IEC 60034-5
- Insulation class or permitted temperature rise
- Type of duty, if other than S1 (Continuous duty)

- Rated nominal power, voltage, frequency, current speed
- Connection instructions (diagram of text if there are more than three connections terminals)
 - Nameplate mounted close to or in the connection box
- Rated nominal power factor
- Max. permitted ambient temperature, if higher than +40 °C
- Min. permitted ambient temperature, if lower than -15 °C
- Max. altitude over sea level, if higher than 1,000 m.a.s.l. (above sea level)
- Total weight, if the weight is over 30 kg
- If only one rotation direction is permitted, it should be marked with an arrow sign (could be separate from rating plate).

Electrical data

All ratings in this catalogue consider:

- Class F insulation / Class B temperature rise
- Maximum 40 °C ambient
- Altitude of 1000 m a.s.l or lower
- Rating list shows typical values. Project guaranteed values are available on request
- All engineered motors are optimized for the specific application. Final motor data can be given on request during quotation phase. Legally binding performances and specification data are given to the end user once order is confirmed.
- Please provide load data and starting requirements to ABB for final design confirmation.

HV Flameproof motors, AMD Rg IIB/IIC

Technical data for totally enclosed squirrel cage three phase motors

6000 V, 50 Hz

IP55 – IC411 – insulation class F, temperature rise class B

Output (kW)	Motor type	Speed (r/min)	Efficiency		Power factor		Current			Torque			Rotor inertia (kgm ²)	Motor weight (kg)	Sound pressure level L _p
			Full load 100%	3/4 load 75%	Full load 100%	3/4 load 75%	I _N (A)	I _S I _N (pu)	I ₀ (A)	T _N (Nm)	T _S T _N (pu)	T _{max} T _N (pu)			
3000 r/min = 2 poles			6000 V 50 Hz												
225	AMD 355L2R B	2973	95.5	95.5	0.91	0.90	25	6.0	5.4	723	0.7	2.4	3.6	2350	79
250	AMD 355L2R B	2972	95.6	95.6	0.91	0.90	28	6.0	6.2	803	0.7	2.4	3.6	2350	79
280	AMD 355L2R B	2974	95.8	95.9	0.91	0.91	31	6.0	6.6	899	0.6	2.4	3.7	2400	79
315	AMD 355L2R B	2979	96.1	96.1	0.91	0.90	34	6.3	7.5	1010	0.7	2.5	3.9	2490	79
350	AMD 355L2R B	2979	96.3	96.4	0.92	0.91	38	6.5	8.2	1122	0.7	2.5	4.2	2580	79
375	AMD 355L2R B	2984	96.5	96.5	0.92	0.91	41	6.2	8.4	1200	0.6	2.3	5.7	2670	79
400	AMD 400L2R B	2977	96.0	95.7	0.91	0.91	44	5.6	9.2	1283	0.6	2.2	6.1	3430	81
450	AMD 400L2R B	2978	96.1	95.9	0.92	0.91	49	6.0	10.5	1443	0.6	2.4	6.9	3610	81
500	AMD 400L2R B	2980	96.3	96.1	0.91	0.89	55	6.0	12.9	1602	0.6	2.4	7.8	3810	81
550	AMD 400L2R B	2986	96.7	96.4	0.91	0.90	60	6.0	12.8	1759	0.6	2.2	10.3	3920	81
630	AMD 450M2R B	2978	96.3	96.4	0.91	0.91	69	5.8	11.6	2020	0.7	2.4	13.6	5710	86
710	AMD 450M2R B	2982	96.5	96.6	0.91	0.90	77	6.4	14.3	2274	0.6	2.7	13.3	5730	86
800	AMD 450M2R B	2980	96.7	96.8	0.90	0.89	88	6.1	16.4	2563	0.7	2.6	14.5	5970	86
900	AMD 450M2R B	2979	96.9	97.0	0.90	0.90	99	6.0	17.8	2885	0.6	2.4	16.8	6440	86
950	AMD 450M2R B	2980	97.0	97.1	0.90	0.89	105	6.1	19.6	3044	0.6	2.5	17.5	6580	86
1060	AMD 450M2R B	2986	97.3	97.3	0.91	0.91	114	6.1	19.6	3390	0.6	2.3	22.4	6770	86
1130	AMD 500S2R B	2986	97.1	97.0	0.91	0.90	123	6.4	23.2	3614	0.6	2.6	24.8	8010	86
1200	AMD 500S2R B	2986	97.1	97.1	0.91	0.90	130	6.4	25.3	3838	0.6	2.5	28.3	8470	86
1290	AMD 500S2R B	2986	97.2	97.2	0.91	0.90	140	6.4	25.8	4125	0.6	2.5	29.2	8650	86
1390	AMD 500M2R B	2987	97.3	97.2	0.92	0.92	149	6.5	26.2	4444	0.6	2.5	32.6	9580	86
1450	AMD 500M2R B	2989	97.4	97.4	0.92	0.92	155	6.4	26.4	4632	0.6	2.2	41.4	9800	86
1500 r/min = 4 poles			6000 V 50 Hz												
160	AMD 355L4R B	1476	93.8	93.5	0.80	0.74	21	6.1	9.7	1035	1.2	2.7	4.8	2260	79
180	AMD 355L4R B	1475	94.0	93.9	0.82	0.77	22	6.1	9.8	1165	1.2	2.6	4.8	2260	79
200	AMD 355L4R B	1485	94.8	94.7	0.84	0.80	24	6.0	9.5	1286	1.0	2.3	4.6	2270	79
225	AMD 355L4R B	1486	95.1	94.9	0.83	0.78	28	6.1	11.4	1446	0.9	2.4	4.8	2310	79
250	AMD 355L4R B	1487	95.3	95.1	0.82	0.77	31	6.2	13.5	1605	0.9	2.4	5.2	2390	79
280	AMD 355L4R B	1488	95.6	95.5	0.83	0.78	34	6.3	14.4	1797	0.9	2.5	5.5	2460	79
340	AMD 355L4R B	1489	96.0	95.8	0.82	0.78	41	6.3	17.6	2181	0.9	2.4	6.5	2670	79
400	AMD 355L4R B	1491	96.4	96.4	0.87	0.84	46	6.2	15.0	2562	0.9	2.2	8.7	2760	79
480	AMD 400L4R B	1492	96.3	96.1	0.88	0.86	54	6.2	16.1	3073	0.7	2.3	12.7	3470	80
550	AMD 400L4R B	1493	96.5	96.3	0.87	0.84	63	6.4	20.3	3519	0.6	2.4	14.1	3640	80
600	AMD 400L4R B	1493	96.7	96.5	0.87	0.85	68	6.3	21.8	3838	0.6	2.3	15.5	3810	80
630	AMD 400L4R B	1493	96.7	96.5	0.87	0.85	72	6.3	22.7	4030	0.6	2.2	16.5	3940	80
710	AMD 450M4R B	1489	96.4	96.4	0.86	0.82	83	6.3	29.5	4554	0.8	2.4	18.6	5420	81
800	AMD 450M4R B	1490	96.6	96.7	0.86	0.83	92	6.3	31.7	5129	0.8	2.5	20.7	5660	81
900	AMD 450M4R B	1490	96.8	96.8	0.86	0.82	104	6.4	37.7	5769	0.8	2.5	22.7	5920	81
1000	AMD 450M4R B	1490	96.9	96.9	0.87	0.85	114	6.4	36.9	6409	0.8	2.4	26.7	6330	81
1080	AMD 450M4R B	1490	96.9	96.9	0.85	0.81	127	6.4	47.9	6919	0.8	2.4	28.5	6530	81
1200	AMD 450M4R B	1493	97.1	97.0	0.86	0.83	138	6.4	46.1	7673	0.6	2.3	36.5	6720	81

HV Flameproof motors, AMD Rg IIB/IIC

Technical data for totally enclosed squirrel cage three phase motors

6000 V, 50 Hz

IP55 – IC411 – insulation class F, temperature rise class B

Output (kW)	Motor type	Speed (r/min)	Efficiency		Power factor		Current			Torque			Rotor inertia (kgm ²)	Motor weight (kg)	Sound pressure level L _p (dB(A))
			Full load 100%	3/4 load 75%	Full load 100%	3/4 load 75%	I _N (A)	I _S I _N (pu)	I ₀ (A)	T _N (Nm)	T _S T _N (pu)	T _{max} T _N (pu)			
1500 r/min = 4 poles			6000 V 50 Hz												
1300	AMD 500S4R B	1492	97.0	97.0	0.86	0.82	151	6.4	56.2	8323	0.7	2.6	44.8	8640	82
1400	AMD 500M4R B	1492	97.2	97.1	0.86	0.82	161	6.4	58.2	8963	0.7	2.6	45.7	9070	82
1500	AMD 500M4R B	1492	97.2	97.2	0.88	0.85	169	6.5	56.0	9602	0.7	2.6	50.5	9500	82
1600	AMD 500M4R B	1494	97.3	97.3	0.89	0.87	178	6.4	50.8	10225	0.7	2.3	67.4	9800	82
1000 r/min = 6 poles			6000 V 50 Hz												
160	AMD 355L6R B	987	94.3	94.2	0.78	0.72	21	5.9	10.7	1547	1.0	2.7	5.6	2380	76
180	AMD 355L6R B	990	94.6	94.5	0.77	0.70	24	5.7	12.7	1737	1.0	2.6	5.5	2380	76
200	AMD 355L6R B	990	95.0	94.9	0.77	0.70	26	5.5	13.7	1930	0.9	2.4	5.5	2400	76
230	AMD 355L6R B	989	95.2	95.2	0.78	0.72	30	5.4	14.5	2220	0.9	2.3	6.1	2520	76
265	AMD 355L6R B	988	95.3	95.3	0.78	0.72	34	5.9	17.2	2560	1.0	2.6	7.2	2700	76
315	AMD 355L6R B	992	95.8	95.9	0.81	0.77	39	5.7	16.5	3032	0.9	2.2	9.2	2780	76
355	AMD 400L6R B	991	95.9	95.6	0.75	0.68	47	6.0	25.6	3420	1.0	2.6	12.2	3620	77
400	AMD 400L6R B	991	96.2	96.1	0.81	0.76	50	5.7	21.9	3855	0.9	2.3	13.2	3800	77
440	AMD 400L6R B	991	96.3	96.3	0.81	0.76	54	5.7	24.0	4239	0.8	2.3	14.3	3970	77
500	AMD 400L6R B	994	96.6	96.6	0.83	0.79	60	5.7	22.9	4804	0.7	2.0	18.6	4050	77
560	AMD 450M6R B	991	96.1	96.2	0.85	0.81	66	6.0	25.4	5397	0.9	2.4	26.2	5380	78
630	AMD 450M6R B	992	96.3	96.4	0.85	0.81	74	6.0	28.3	6067	0.9	2.3	28.8	5560	78
710	AMD 450M6R B	992	96.4	96.6	0.85	0.81	84	5.9	31.2	6837	0.8	2.3	32.9	5860	78
800	AMD 450M6R B	992	96.6	96.7	0.84	0.80	95	6.0	37.6	7699	0.8	2.4	37.1	6160	78
860	AMD 450M6R B	992	96.7	96.9	0.87	0.85	98	6.0	31.8	8282	0.9	2.3	41.6	6510	78
975	AMD 450M6R B	995	96.9	97.0	0.86	0.83	113	6.0	37.4	9357	0.7	2.1	53.3	6720	78
1000	AMD 500S6R B	993	96.8	96.9	0.83	0.78	120	5.9	49.6	9612	0.7	2.4	56.3	8360	79
1100	AMD 500S6R B	993	96.9	97.0	0.84	0.80	129	6.0	49.9	10575	0.7	2.4	63.9	8810	79
1200	AMD 500M6R B	994	97.0	97.1	0.84	0.79	142	6.0	57.4	11533	0.7	2.5	69.0	9430	79
1290	AMD 500M6R B	994	97.1	97.1	0.82	0.77	156	6.0	66.0	12398	0.7	2.4	75.1	9750	79
1400	AMD 500M6R B	996	97.3	97.3	0.86	0.83	161	6.0	54.4	13427	0.7	2.2	95.6	10040	79
750 r/min = 8 poles			6000 V 50 Hz												
150	AMD 400L8R B	741	94.4	94.5	0.76	0.71	20	4.4	9.7	1932	0.7	1.9	9.3	3190	70
180	AMD 400L8R B	741	94.7	94.6	0.75	0.68	24	5.0	12.9	2320	0.9	2.2	10.7	3360	70
200	AMD 400L8R B	742	95.0	95.0	0.75	0.68	27	4.8	14.2	2574	0.8	2.1	11.2	3460	70
235	AMD 400L8R B	742	95.2	95.3	0.76	0.70	31	4.8	15.5	3025	0.8	2.0	12.9	3690	70
275	AMD 400L8R B	742	95.4	95.5	0.76	0.71	36	4.8	17.8	3541	0.9	2.0	15.0	3970	70
315	AMD 400L8R B	744	95.8	95.6	0.76	0.69	42	6.2	22.8	4044	1.0	2.7	18.7	4060	70
355	AMD 450M8R B	742	95.1	95.4	0.83	0.79	43	4.7	16.7	4566	0.7	1.9	25.2	5260	77
400	AMD 450M8R B	743	95.4	95.5	0.81	0.76	50	5.5	21.8	5141	0.9	2.2	26.9	5360	77
450	AMD 450M8R B	743	95.6	95.8	0.81	0.77	56	5.3	23.7	5782	0.8	2.1	30.2	5610	77
490	AMD 450M8R B	744	95.7	95.9	0.81	0.76	61	5.5	27.0	6293	0.8	2.2	32.7	5790	77
540	AMD 450M8R B	744	95.9	96.0	0.80	0.74	68	5.8	31.6	6931	0.9	2.3	35.6	5990	77
630	AMD 450M8R B	743	96.1	96.1	0.79	0.73	80	5.9	39.2	8097	1.1	2.4	40.0	6300	77

HV Flameproof motors, AMD Rg IIB/IIC

Technical data for totally enclosed squirrel cage three phase motors

6000 V, 50 Hz

IP55 – IC411 – insulation class F, temperature rise class B

Output (kW)	Motor type	Speed (r/min)	Efficiency		Power factor		Current			Torque			Rotor inertia (kgm ²)	Motor weight (kg)	Sound pressure level L _p (dB(A))
			Full load 100%	3/4 load 75%	Full load 100%	3/4 load 75%	I _N (A)	I _s I _N (pu)	I ₀ (A)	T _N (Nm)	T _s T _N (pu)	T _{max} T _N (pu)			
750 r/min = 8 poles		6000 V 50 Hz													
670	AMD 450M8R B	743	96.1	96.1	0.80	0.74	84	5.9	39.2	8612	1.0	2.4	44.3	6570	77
750	AMD 450M8R B	745	96.5	96.5	0.82	0.78	91	5.9	37.9	9608	0.8	2.3	55.6	6770	77
800	AMD 500S8R B	743	96.3	96.4	0.82	0.77	98	5.5	40.3	10276	0.9	2.1	57.8	8370	78
875	AMD 500S8R B	744	96.4	96.4	0.81	0.76	108	5.9	48.2	11231	0.9	2.4	65.5	8800	78
930	AMD 500M8R B	744	96.4	96.3	0.80	0.74	117	6.0	54.1	11939	1.0	2.4	68.8	9260	78
1025	AMD 500M8R B	744	96.5	96.4	0.80	0.74	128	5.9	59.5	13155	1.0	2.4	76.2	9730	78
1150	AMD 500M8R B	746	96.8	96.8	0.82	0.78	139	5.9	56.3	14719	0.8	2.2	95.8	10010	78
600 r/min = 10 poles		6000 V 50 Hz													
300	AMD 450M10R B	592	94.8	95.2	0.76	0.71	40	4.3	18.8	4839	0.8	1.8	25.9	5290	77
335	AMD 450M10R B	593	95.0	95.3	0.75	0.70	45	4.3	22.2	5398	0.8	1.8	27.3	5410	77
400	AMD 450M10R B	593	95.3	95.6	0.76	0.71	53	4.5	25.6	6445	0.8	1.9	32.9	5780	77
450	AMD 450M10R B	593	95.5	95.7	0.76	0.71	60	4.5	28.6	7248	0.8	1.9	37.2	6100	77
500	AMD 450M10R B	593	95.6	95.8	0.76	0.70	66	4.6	32.8	8048	0.9	2.0	41.8	6420	77
540	AMD 450M10R B	594	95.7	95.7	0.72	0.65	75	5.3	42.2	8683	1.1	2.3	44.8	6580	77
600	AMD 450M10R B	596	96.2	96.2	0.75	0.69	80	5.4	40.6	9611	0.9	2.0	56.2	6790	77
630	AMD 500S10R B	594	95.9	95.9	0.75	0.68	84	5.4	44.4	10126	1.1	2.2	61.8	8470	78
670	AMD 500S10R B	594	95.9	96.0	0.75	0.69	89	5.5	46.9	10766	1.1	2.3	67.9	8800	78
750	AMD 500M10R B	594	96.0	96.1	0.78	0.72	97	5.2	46.2	12062	1.0	2.1	78.4	9690	78
825	AMD 500M10R B	596	96.3	96.4	0.79	0.75	104	5.2	43.6	13227	0.9	1.8	95.4	9940	78
500 r/min = 12 poles		6000 V 50 Hz													
250	AMD 450M12R B	492	93.9	94.0	0.71	0.65	36	3.8	19.3	4850	0.8	1.8	29.7	5550	77
290	AMD 450M12R B	492	94.1	94.3	0.71	0.66	42	3.8	21.7	5624	0.7	1.7	33.7	5840	77
330	AMD 450M12R B	493	94.4	94.5	0.71	0.65	47	3.9	25.4	6395	0.8	1.8	38.6	6180	77
380	AMD 450M12R B	494	94.7	94.6	0.70	0.63	56	4.2	31.4	7349	0.9	1.9	44.1	6570	77
425	AMD 450M12R B	496	95.2	95.1	0.72	0.66	60	4.1	31.1	8185	0.6	1.7	56.0	6780	77
460	AMD 500S12R B	494	94.9	94.9	0.73	0.67	64	4.1	33.7	8888	0.7	1.8	58.0	8300	78
510	AMD 500S12R B	495	95.0	94.8	0.69	0.62	75	4.6	44.4	9835	0.9	2.1	67.3	8820	78
560	AMD 500M12R B	495	95.1	95.0	0.72	0.66	79	4.4	42.8	10807	0.8	2.0	76.7	9660	78
630	AMD 500M12R B	497	95.4	95.1	0.72	0.65	88	5.0	49.5	12117	0.8	2.2	95.2	9920	78
425 r/min = 14 poles		6000 V 50 Hz													
240	AMD 450M14R B	425	93.6	93.5	0.67	0.60	37	3.8	22.0	5399	0.6	1.8	43.7	6040	77
300	AMD 450M14R B	425	94.1	93.8	0.66	0.59	46	4.0	28.2	6744	0.7	1.9	55.6	6750	77
355	AMD 500S14R B	425	94.6	94.3	0.66	0.59	55	4.2	33.2	7980	0.8	1.9	71.8	8520	78
400	AMD 500S14R B	425	94.8	94.6	0.68	0.62	59	4.0	33.7	8998	0.7	1.8	83.4	9100	78
470	AMD 500M14R B	425	94.7	94.4	0.67	0.60	71	4.3	42.5	10566	0.8	1.9	95.0	9940	78
375 r/min = 16 poles		6000 V 50 Hz													
400	AMD 500S16R B	372	94.4	94.0	0.66	0.59	62	4.0	37.7	10272	0.7	1.9	109.0	9090	78
325 r/min = 18 poles		6000 V 50 Hz													
280	AMD 500S18R B	329	92.9	92.7	0.65	0.57	45	3.7	27.7	8133	0.8	1.8	107.5	9030	78

HV Flameproof motors, AMD Rg IIB/IIC

Technical data for totally enclosed squirrel cage three phase motors

10000 V, 50 Hz

IP55 – IC411 – insulation class F, temperature rise class B

Output (kW)	Motor type	Speed (r/min)	Efficiency		Power factor		Current			Torque			Rotor inertia (kgm ²)	Motor weight (kg)	Sound pressure level L _p (dB(A))
			Full load 100%	3/4 load 75%	Full load 100%	3/4 load 75%	I _N (A)	I _S I _N (pu)	I ₀ (A)	T _N (Nm)	T _S T _N (pu)	T _{max} T _N (pu)			
3000 r/min = 2 poles			10000 V 50 Hz												
250	AMD 400L2R B	2977	94.3	93.7	0.90	0.87	17	6.5	5.1	802	0.6	2.8	6.6	3410	81
280	AMD 400L2R B	2978	94.5	94.1	0.91	0.89	19	6.2	5.1	898	0.7	2.6	6.5	3410	81
315	AMD 400L2R B	2981	94.9	94.6	0.92	0.90	21	6.4	5.2	1009	0.6	2.6	6.6	3460	81
375	AMD 400L2R B	2983	95.5	95.2	0.91	0.90	25	6.4	6.2	1200	0.5	2.6	6.7	3570	81
390	AMD 400L2R B	2988	95.7	95.4	0.92	0.90	26	6.4	5.9	1246	0.5	2.5	9.4	3680	81
450	AMD 450M2R B	2981	95.9	95.8	0.93	0.92	29	6.3	5.1	1441	0.6	2.6	13.8	5800	86
500	AMD 450M2R B	2981	96.0	96.0	0.92	0.92	32	6.4	5.7	1602	0.7	2.6	13.8	5810	86
560	AMD 450M2R B	2981	96.1	96.2	0.92	0.91	36	6.5	6.4	1794	0.7	2.7	13.8	5810	86
630	AMD 450M2R B	2980	96.3	96.3	0.90	0.89	42	6.5	8.3	2019	0.7	2.6	14.1	5830	86
725	AMD 450M2R B	2981	96.5	96.6	0.90	0.89	48	6.4	9.3	2323	0.8	2.6	15.5	6140	86
840	AMD 500S2R B	2982	96.5	96.5	0.92	0.92	54	6.5	9.9	2690	0.7	2.6	24.9	7920	86
1000	AMD 500S2R B	2983	96.8	96.8	0.92	0.92	64	6.5	11.2	3201	0.8	2.4	28.8	8480	86
1100	AMD 500S2R B	2987	97.0	97.0	0.91	0.90	72	6.4	13.9	3516	0.7	2.3	34.7	8640	86
1200	AMD 500M2R B	2987	97.0	96.9	0.88	0.87	80	6.1	18.1	3836	0.8	2.3	39.0	9580	86
1500 r/min = 4 poles			10000 V 50 Hz												
225	AMD 400L4R B	1482	93.8	93.1	0.81	0.75	17	6.5	8.1	1450	1.1	2.8	8.2	3420	80
250	AMD 400L4R B	1484	94.2	93.6	0.82	0.77	19	6.2	8.2	1609	0.9	2.7	8.1	3410	80
280	AMD 400L4R B	1484	94.5	94.1	0.84	0.80	20	6.2	8.1	1801	1.0	2.4	8.0	3410	80
315	AMD 400L4R B	1488	95.0	94.7	0.86	0.82	22	6.4	8.2	2022	0.8	2.6	7.7	3420	80
355	AMD 400L4R B	1490	95.4	95.0	0.85	0.80	25	6.4	10.0	2275	0.8	2.6	7.9	3490	80
430	AMD 400L4R B	1490	95.8	95.5	0.86	0.83	30	6.5	10.9	2756	0.7	2.5	9.2	3740	80
500	AMD 400L4R B	1492	96.0	95.8	0.86	0.84	35	5.9	11.1	3201	0.8	2.2	12.5	3860	80
560	AMD 450M4R B	1488	96.0	96.0	0.86	0.82	39	6.1	14.4	3594	0.8	2.5	13.5	5450	81
630	AMD 450M4R B	1489	96.2	96.2	0.84	0.80	45	6.5	18.1	4041	0.9	2.7	14.5	5610	81
710	AMD 450M4R B	1489	96.5	96.4	0.84	0.80	50	6.4	20.5	4552	0.8	2.6	16.2	5910	81
770	AMD 450M4R B	1489	96.5	96.5	0.84	0.80	55	5.9	21.5	4940	0.7	2.5	18.1	6190	81
850	AMD 500S4R B	1490	96.5	96.4	0.85	0.80	60	6.3	24.1	5447	0.6	2.7	30.7	7750	82
1000	AMD 500S4R B	1491	96.8	96.7	0.84	0.80	71	6.5	29.1	6405	0.7	2.8	36.2	8290	82
1100	AMD 500M4R B	1491	96.9	96.9	0.88	0.85	75	6.4	24.2	7047	0.8	2.6	40.4	8970	82
1200	AMD 500M4R B	1493	96.9	96.9	0.87	0.83	82	6.1	28.8	7677	0.6	2.6	49.8	9180	82
1280	AMD 500M4R B	1495	97.1	97.0	0.87	0.83	88	6.5	30.7	8178	0.6	2.5	53.4	9380	82

HV Flameproof motors, AMD Rg IIB/IIC

Technical data for totally enclosed squirrel cage three phase motors

10000 V, 50 Hz

IP55 – IC411 – insulation class F, temperature rise class B

Output (kW)	Motor type	Speed (r/min)	Efficiency		Power factor		Current			Torque			Rotor inertia (kgm ²)	Motor weight (kg)	Sound pressure level L _p (dB(A))
			Full load 100%	3/4 load 75%	Full load 100%	3/4 load 75%	I _N (A)	I _s I _N (pu)	I ₀ (A)	T _N (Nm)	T _s T _N (pu)	T _{max} T _N (pu)			
1000 r/min = 6 poles		10000 V 50 Hz													
200	AMD 400L6R B	989	94.2	93.7	0.73	0.65	17	6.0	9.9	1932	1.1	3.0	9.8	3580	77
225	AMD 400L6R B	987	94.2	93.9	0.76	0.69	18	5.7	9.9	2177	1.0	2.8	9.8	3580	77
250	AMD 400L6R B	990	94.7	94.3	0.75	0.68	20	5.7	11.2	2412	1.0	2.7	10.1	3670	77
285	AMD 400L6R B	992	95.1	94.7	0.72	0.64	24	5.8	14.3	2742	0.9	2.7	10.3	3770	77
355	AMD 400L6R B	994	95.7	95.5	0.77	0.71	28	5.3	13.9	3409	0.6	2.2	13.5	3890	77
400	AMD 450M6R B	992	95.4	95.4	0.81	0.76	30	5.3	13.2	3849	0.7	2.2	17.0	5480	78
450	AMD 450M6R B	992	95.6	95.6	0.81	0.76	34	5.4	14.9	4330	0.7	2.2	18.2	5630	78
500	AMD 450M6R B	993	95.8	95.8	0.80	0.74	38	5.6	17.6	4810	0.8	2.3	19.5	5780	78
560	AMD 450M6R B	993	96.0	95.9	0.80	0.75	42	5.8	19.3	5386	0.8	2.3	21.9	6080	78
625	AMD 450M6R B	993	96.2	96.1	0.79	0.73	47	6.1	23.0	6008	0.9	2.5	24.3	6370	78
800	AMD 500S6R B	994	96.6	96.5	0.79	0.73	61	6.2	29.6	7685	0.8	2.6	43.1	8380	79
900	AMD 500M6R B	994	96.7	96.7	0.81	0.76	66	6.0	29.3	8649	0.8	2.5	44.3	8830	79
990	AMD 500M6R B	994	96.8	96.8	0.81	0.75	73	6.3	33.4	9511	0.8	2.6	48.7	9190	79
1150	AMD 500M6R B	996	97.1	97.1	0.84	0.80	81	6.2	31.5	11026	0.6	2.3	64.2	9510	79
750 r/min = 8 poles		10000 V 50 Hz													
315	AMD 450M8R B	746	94.9	94.5	0.70	0.61	27	6.0	17.4	4034	0.9	2.8	27.9	5520	77
355	AMD 450M8R B	745	94.9	94.6	0.71	0.63	30	6.3	18.6	4549	1.2	2.8	28.5	5540	77
400	AMD 450M8R B	744	95.2	95.2	0.79	0.74	31	5.9	14.8	5132	0.9	2.4	32.2	5820	77
440	AMD 450M8R B	745	95.4	95.2	0.75	0.68	35	5.7	19.4	5640	0.9	2.5	34.1	5960	77
500	AMD 450M8R B	745	95.6	95.4	0.74	0.66	41	6.4	23.6	6406	1.1	2.8	38.4	6250	77
560	AMD 500S8R B	744	95.6	95.5	0.77	0.71	44	5.1	21.6	7185	0.7	2.2	40.3	8130	78
610	AMD 500M8R B	745	95.7	95.5	0.75	0.68	49	5.4	26.4	7822	0.8	2.4	43.2	8640	78
700	AMD 500M8R B	745	95.9	95.6	0.72	0.64	59	5.6	34.2	8971	0.9	2.5	47.6	9010	78
775	AMD 500M8R B	747	96.3	96.1	0.75	0.68	62	5.9	33.4	9909	0.7	2.3	57.7	9070	78
850	AMD 500M8R B	746	96.3	96.1	0.76	0.70	67	6.5	35.3	10877	0.9	2.7	63.2	9440	78
600 r/min = 10 poles		10000 V 50 Hz													
280	AMD 450M10R B	595	94.3	93.8	0.60	0.52	28	4.2	19.8	4492	0.7	2.2	24.0	5960	77
310	AMD 450M10R B	595	94.4	94.1	0.63	0.55	30	4.1	20.1	4977	0.7	2.1	25.4	6110	77
370	AMD 500S10R B	595	94.6	94.6	0.73	0.66	31	5.1	17.1	5937	0.9	2.2	47.6	7700	78
440	AMD 500S10R B	596	95.1	95.0	0.74	0.67	36	5.2	20.1	7055	0.8	2.3	55.8	8220	78
500	AMD 500M10R B	595	95.2	95.0	0.71	0.63	43	5.7	25.5	8019	1.1	2.5	61.3	8740	78
545	AMD 500M10R B	596	95.3	95.1	0.69	0.61	48	5.2	29.2	8735	0.9	2.3	66.9	9090	78
600	AMD 500M10R B	596	95.6	95.5	0.74	0.68	49	5.8	26.3	9607	1.0	2.3	82.0	9330	78
500 r/min = 12 poles		10000 V 50 Hz													
265	AMD 500S12R B	495	93.1	92.6	0.68	0.60	24	5.0	15.4	5113	1.0	2.5	51.8	7880	78
315	AMD 500M12R B	497	93.4	92.5	0.57	0.48	34	4.8	25.7	6053	0.9	2.7	59.2	8700	78
430	AMD 500M12R B	497	94.3	93.8	0.69	0.61	38	5.4	23.8	8260	0.9	2.5	82.4	9330	78

HV Flameproof motors, AMD Rg IIB/IIC

Technical data for totally enclosed squirrel cage three phase motors

11000 V, 50 Hz

IP55 – IC411 – insulation class F, temperature rise class B

Output (kW)	Motor type	Speed (r/min)	Efficiency		Power factor		Current			Torque			Rotor inertia (kgm ²)	Motor weight (kg)	Sound pressure level L _p (dB(A))
			Full load 100%	3/4 load 75%	Full load 100%	3/4 load 75%	I _N (A)	I _S I _N (pu)	I ₀ (A)	T _N (Nm)	T _S T _N (pu)	T _{max} T _N (pu)			
3000 r/min = 2 poles		11000 V 50 Hz													
250	AMD 400L2R B	2981	94.5	93.9	0.90	0.88	15	6.4	4.4	801	0.7	2.6	7.0	3510	81
280	AMD 400L2R B	2977	94.7	94.2	0.91	0.89	17	6.4	4.4	898	0.7	2.5	7.1	3510	81
315	AMD 400L2R B	2978	94.9	94.6	0.92	0.90	19	6.2	4.4	1010	0.7	2.5	6.9	3500	81
380	AMD 400L2R B	2983	95.6	95.3	0.91	0.90	23	6.3	5.6	1216	0.6	2.5	6.7	3570	81
400	AMD 400L2R B	2987	95.8	95.5	0.92	0.91	24	6.4	5.4	1279	0.6	2.4	9.3	3680	81
450	AMD 450M2R B	2975	95.6	95.6	0.91	0.90	27	6.1	5.3	1445	0.9	2.5	14.3	5750	86
500	AMD 450M2R B	2973	95.6	95.7	0.92	0.91	30	6.0	5.3	1606	0.8	2.4	14.2	5750	86
560	AMD 450M2R B	2975	95.9	96.0	0.91	0.90	34	6.3	6.5	1797	0.8	2.6	14.1	5760	86
630	AMD 450M2R B	2981	96.2	96.3	0.90	0.89	38	6.4	7.3	2018	0.7	2.6	13.7	5770	86
725	AMD 450M2R B	2980	96.5	96.6	0.91	0.91	43	6.2	7.6	2323	0.7	2.5	14.5	5990	86
840	AMD 450M2R B	2981	96.7	96.8	0.89	0.89	51	6.4	10.1	2690	0.7	2.6	16.2	6300	86
900	AMD 450M2R B	2987	97.0	97.0	0.91	0.90	53	6.4	10.1	2877	0.6	2.5	20.6	6440	86
1000	AMD 500S2R B	2985	96.8	96.8	0.91	0.90	59	6.4	12.1	3200	0.6	2.5	25.8	8100	86
1100	AMD 500S2R B	2984	96.9	96.9	0.91	0.91	65	6.4	12.5	3520	0.6	2.5	28.5	8470	86
1200	AMD 500M2R B	2985	97.0	97.0	0.92	0.92	70	6.5	12.7	3838	0.6	2.4	31.7	9390	86
1240	AMD 500M2R B	2988	97.1	97.1	0.92	0.92	72	6.5	12.6	3963	0.7	2.3	39.9	9590	86
1500 r/min = 4 poles		11000 V 50 Hz													
250	AMD 400L4R B	1487	94.4	93.7	0.81	0.75	17	6.4	8.0	1605	1.0	2.7	8.5	3490	80
280	AMD 400L4R B	1483	94.4	93.9	0.83	0.78	19	6.2	8.1	1803	0.9	2.7	8.5	3490	80
315	AMD 400L4R B	1485	94.8	94.4	0.84	0.80	21	6.4	8.3	2025	1.0	2.5	8.6	3500	80
355	AMD 400L4R B	1488	95.3	94.9	0.85	0.81	23	6.4	8.9	2277	0.8	2.6	8.5	3560	80
415	AMD 400L4R B	1489	95.6	95.2	0.84	0.80	27	6.3	11.0	2661	0.7	2.6	9.3	3720	80
500	AMD 400L4R B	1492	96.1	95.9	0.88	0.85	31	6.3	10.0	3200	0.7	2.4	12.4	3850	80
560	AMD 450M4R B	1487	95.9	95.9	0.85	0.81	36	6.2	13.7	3597	0.9	2.5	13.9	5450	81
630	AMD 450M4R B	1489	96.2	96.2	0.84	0.80	41	6.4	16.5	4041	0.8	2.7	14.6	5620	81
710	AMD 450M4R B	1489	96.4	96.4	0.85	0.81	46	6.3	17.9	4554	0.8	2.6	16.2	5890	81
770	AMD 450M4R B	1489	96.5	96.5	0.86	0.82	49	6.4	18.0	4939	0.8	2.6	17.5	6080	81
850	AMD 450M4R B	1489	96.6	96.6	0.85	0.81	54	6.3	21.0	5451	0.7	2.5	18.9	6350	81
925	AMD 450M4R B	1492	96.8	96.8	0.86	0.83	58	6.3	19.8	5920	0.8	2.3	24.4	6500	81
1000	AMD 500S4R B	1491	96.8	96.8	0.87	0.84	62	6.2	21.4	6404	0.7	2.5	36.0	8300	82
1100	AMD 500M4R B	1490	96.8	96.9	0.89	0.86	67	6.4	21.0	7048	0.7	2.6	39.2	8890	82
1200	AMD 500M4R B	1491	97.0	97.0	0.88	0.85	74	6.4	24.7	7686	0.7	2.6	41.8	9150	82
1280	AMD 500M4R B	1494	97.1	97.0	0.88	0.86	78	6.5	22.9	8182	0.7	2.2	55.1	9410	82

HV Flameproof motors, AMD Rg IIB/IIC

Technical data for totally enclosed squirrel cage three phase motors

11000 V, 50 Hz

IP55 – IC411 – insulation class F, temperature rise class B

Output (kW)	Motor type	Speed (r/min)	Efficiency		Power factor		Current			Torque			Rotor inertia (kgm ²)	Motor weight (kg)	Sound pressure level L _p (dB(A))
			Full load 100%	3/4 load 75%	Full load 100%	3/4 load 75%	I _N (A)	I _S I _N (pu)	I ₀ (A)	T _N (Nm)	T _S T _N (pu)	T _{max} T _N (pu)			
1000 r/min = 6 poles			11000 V 50 Hz												
225	AMD 400L6R B	989	94.3	93.8	0.72	0.64	17	5.9	10.4	2173	1.0	3.0	10.2	3660	77
250	AMD 400L6R B	989	94.6	94.2	0.75	0.68	19	5.9	10.4	2415	1.0	2.9	10.3	3690	77
280	AMD 400L6R B	991	95.0	94.6	0.73	0.66	21	5.9	12.2	2698	0.9	2.8	10.6	3770	77
350	AMD 400L6R B	994	95.6	95.3	0.76	0.69	25	5.8	13.5	3362	0.7	2.5	13.4	3880	77
400	AMD 450M6R B	989	95.0	95.0	0.82	0.77	27	5.8	11.7	3863	1.0	2.5	18.1	5490	78
450	AMD 450M6R B	992	95.5	95.5	0.81	0.76	31	5.3	13.3	4332	0.7	2.2	18.0	5590	78
500	AMD 450M6R B	991	95.7	95.7	0.83	0.79	33	5.2	13.0	4816	0.7	2.1	20.6	5870	78
560	AMD 450M6R B	990	95.7	95.7	0.83	0.78	37	6.0	15.5	5402	1.0	2.5	24.0	6200	78
625	AMD 450M6R B	991	95.9	95.8	0.81	0.76	42	6.0	19.0	6021	1.0	2.4	25.5	6400	78
710	AMD 450M6R B	995	96.5	96.5	0.84	0.80	46	5.8	17.4	6815	0.7	2.1	32.2	6590	78
800	AMD 500S6R B	994	96.5	96.5	0.82	0.77	53	5.9	23.4	7689	0.7	2.4	40.8	8220	79
900	AMD 500M6R B	993	96.6	96.7	0.85	0.81	58	6.0	21.8	8658	0.8	2.4	47.4	9010	79
990	AMD 500M6R B	993	96.7	96.7	0.83	0.79	65	5.9	26.3	9522	0.8	2.4	49.6	9210	79
1150	AMD 500M6R B	996	97.0	97.1	0.85	0.81	73	5.9	26.8	11029	0.6	2.3	64.2	9510	79
750 r/min = 8 poles			11000 V 50 Hz												
315	AMD 450M8R B	742	94.5	94.1	0.73	0.65	24	5.9	14.3	4054	1.1	2.9	32.6	5720	77
355	AMD 450M8R B	742	94.5	94.2	0.73	0.65	27	6.0	15.9	4572	1.1	2.9	33.5	5780	77
400	AMD 450M8R B	745	95.1	94.9	0.75	0.68	30	6.0	16.6	5128	1.0	2.6	32.6	5820	77
440	AMD 450M8R B	744	95.2	95.1	0.78	0.72	31	6.0	15.8	5649	1.0	2.6	36.6	6060	77
500	AMD 450M8R B	744	95.5	95.4	0.80	0.74	35	6.0	16.6	6418	1.0	2.5	39.2	6260	77
540	AMD 450M8R B	746	95.7	95.7	0.82	0.77	36	5.9	15.8	6913	0.8	2.3	50.5	6500	77
560	AMD 500S8R B	743	95.4	95.3	0.78	0.72	40	5.9	19.9	7193	1.0	2.5	40.6	8060	78
610	AMD 500S8R B	744	95.6	95.5	0.78	0.72	43	5.8	21.1	7834	1.0	2.4	43.7	8330	78
700	AMD 500M8R B	743	95.8	95.7	0.79	0.73	49	5.5	23.3	8995	0.9	2.3	46.7	8880	78
775	AMD 500M8R B	744	96.0	96.0	0.78	0.72	54	5.3	26.1	9947	0.8	2.2	49.9	9210	78
850	AMD 500M8R B	745	96.3	96.3	0.82	0.78	56	5.4	22.9	10889	0.7	2.1	64.5	9510	78
600 r/min = 10 poles			11000 V 50 Hz												
280	AMD 450M10R B	594	93.7	93.3	0.65	0.57	24	4.0	15.4	4504	0.7	2.0	25.5	6050	77
310	AMD 450M10R B	594	93.9	93.5	0.65	0.58	27	4.0	16.8	4987	0.7	2.0	27.7	6270	77
350	AMD 450M10R B	595	94.3	93.8	0.66	0.58	30	4.3	18.6	5619	0.6	2.2	34.8	6450	77
370	AMD 500S10R B	594	94.4	94.4	0.74	0.67	28	5.3	15.3	5951	1.0	2.3	49.8	7750	78
440	AMD 500S10R B	593	94.7	94.8	0.76	0.70	32	4.9	16.3	7084	1.0	2.1	59.5	8280	78
500	AMD 500M10R B	594	95.0	94.9	0.73	0.65	38	5.7	21.9	8036	1.1	2.5	63.4	8800	78
545	AMD 500M10R B	594	95.1	95.0	0.73	0.65	41	5.8	23.9	8758	1.1	2.5	69.4	9130	78
600	AMD 500M10R B	596	95.6	95.5	0.75	0.68	44	5.7	23.3	9608	0.9	2.3	82.0	9330	78
500 r/min = 12 poles			11000 V 50 Hz												
265	AMD 500S12R B	494	92.7	92.2	0.67	0.59	22	5.2	14.7	5123	1.0	2.7	53.3	7920	78
315	AMD 500M12R B	494	93.3	93.1	0.72	0.65	25	4.6	14.1	6088	0.8	2.2	59.2	8590	78
375	AMD 500M12R B	495	93.9	93.7	0.72	0.65	29	4.3	16.5	7229	0.7	2.0	65.5	9050	78
430	AMD 500M12R B	497	94.3	94.1	0.73	0.66	33	4.9	18.1	8268	0.7	2.2	82.4	9320	78

HV Flameproof motors, AMD Rg IIB/IIC

Technical data for totally enclosed squirrel cage three phase motors

6600 V, 60 Hz

IP55 – IC411 – insulation class F, temperature rise class B

Output (kW)	Motor type	Speed (r/min)	Efficiency		Power factor		Current			Torque			Rotor inertia (kgm ²)	Motor weight (kg)	Sound pressure level L _p (dB(A))
			Full load 100%	3/4 load 75%	Full load 100%	3/4 load 75%	I _N (A)	I _S I _N (pu)	I ₀ (A)	T _N (Nm)	T _S T _N (pu)	T _{max} T _N (pu)			
3600 r/min = 2 poles			6600 V 60 Hz												
250	AMD 355L2R B	3571	95.1	94.7	0.90	0.89	25	6.2	6.1	669	0.8	2.4	3.7	2350	81
280	AMD 355L2R B	3578	95.5	95.2	0.91	0.90	28	6.2	6.5	747	0.6	2.5	3.4	2340	81
315	AMD 355L2R B	3580	95.8	95.5	0.91	0.90	31	6.4	7.3	840	0.6	2.5	3.7	2430	81
370	AMD 355L2R B	3581	96.1	95.9	0.91	0.90	37	6.4	8.2	987	0.5	2.5	4.1	2560	81
400	AMD 355L2R B	3584	96.3	96.1	0.91	0.91	40	6.4	8.4	1066	0.6	2.3	5.7	2670	81
450	AMD 400L2R B	3581	95.6	95.0	0.91	0.90	45	6.5	11.0	1200	0.6	2.6	6.3	3480	84
500	AMD 400L2R B	3582	95.9	95.4	0.92	0.91	49	6.4	10.6	1333	0.6	2.5	6.8	3630	84
540	AMD 400L2R B	3583	96.1	95.6	0.92	0.91	53	6.4	11.0	1439	0.5	2.5	7.4	3790	84
575	AMD 400L2R B	3587	96.3	95.9	0.92	0.92	56	6.5	10.8	1531	0.5	2.4	10.4	3920	84
630	AMD 450M2R B	3571	95.7	95.6	0.92	0.91	62	5.7	10.5	1685	0.7	2.3	14.2	5730	91
710	AMD 450M2R B	3576	96.1	96.0	0.91	0.91	70	5.7	11.7	1896	0.6	2.4	13.7	5740	91
800	AMD 450M2R B	3580	96.4	96.2	0.91	0.90	80	6.4	14.6	2134	0.6	2.7	13.5	5730	91
900	AMD 450M2R B	3582	96.6	96.5	0.91	0.91	89	6.4	16.0	2399	0.6	2.7	14.5	6010	91
1000	AMD 450M2R B	3582	96.8	96.7	0.91	0.91	99	6.4	17.6	2666	0.6	2.6	15.5	6270	91
1060	AMD 450M2R B	3582	96.9	96.8	0.92	0.91	104	6.4	17.9	2826	0.6	2.6	16.9	6560	91
1140	AMD 450M2R B	3587	97.1	97.0	0.92	0.92	111	6.5	17.8	3035	0.6	2.4	22.7	6750	91
1200	AMD 500M2R B	3585	96.6	96.4	0.93	0.93	116	6.3	19.4	3197	0.5	2.5	27.2	8800	91
1250	AMD 500M2R B	3584	96.7	96.5	0.93	0.93	121	6.4	20.9	3330	0.6	2.5	29.7	9100	91
1375	AMD 500M2R B	3584	96.8	96.6	0.92	0.92	134	6.5	23.9	3663	0.6	2.4	33.7	9610	91
1450	AMD 500M2R B	3588	97.0	96.8	0.92	0.92	141	6.4	23.9	3859	0.6	2.2	41.6	9800	91
1800 r/min = 4 poles			6600 V 60 Hz												
170	AMD 355L4R B	1779	93.7	93.0	0.82	0.77	19	6.1	8.7	913	1.0	2.7	4.8	2260	81
200	AMD 355L4R B	1781	94.3	93.8	0.84	0.80	22	6.0	8.7	1072	1.0	2.4	4.7	2250	81
240	AMD 355L4R B	1783	94.7	94.3	0.84	0.80	26	6.3	10.5	1285	1.0	2.5	4.8	2280	81
280	AMD 355L4R B	1786	95.1	94.8	0.84	0.80	31	6.3	12.1	1497	0.9	2.5	5.1	2360	81
315	AMD 355L4R B	1787	95.4	95.1	0.84	0.79	35	6.4	13.9	1684	0.9	2.5	5.5	2450	81
355	AMD 355L4R B	1788	95.7	95.4	0.84	0.80	39	6.4	15.0	1896	0.9	2.5	6.1	2570	81
390	AMD 355L4R B	1787	95.9	95.7	0.84	0.80	42	6.5	16.4	2084	1.0	2.4	6.6	2680	81
400	AMD 355L4R B	1786	96.0	95.8	0.86	0.84	42	6.0	13.5	2139	0.9	2.1	8.3	2730	81
450	AMD 400L4R B	1789	95.5	95.0	0.86	0.82	48	6.3	17.3	2402	0.7	2.5	9.3	3370	83
500	AMD 400L4R B	1789	95.8	95.3	0.87	0.84	53	6.4	18.1	2669	0.7	2.5	10.1	3490	83
560	AMD 400L4R B	1789	96.0	95.6	0.88	0.85	58	6.4	18.7	2989	0.7	2.5	11.2	3660	83
630	AMD 400L4R B	1791	96.2	95.9	0.89	0.87	64	6.3	17.7	3360	0.7	2.3	14.8	3750	83
710	AMD 450M4R B	1786	96.2	96.2	0.89	0.87	73	6.2	21.2	3796	0.7	2.4	18.3	5350	85
800	AMD 450M4R B	1788	96.5	96.4	0.88	0.86	82	6.4	25.1	4271	0.7	2.5	18.8	5450	85
880	AMD 450M4R B	1789	96.6	96.5	0.87	0.84	92	6.4	31.5	4697	0.7	2.6	19.7	5590	85
1000	AMD 450M4R B	1790	96.8	96.7	0.87	0.84	104	6.4	35.1	5335	0.7	2.4	23.6	5990	85
1120	AMD 450M4R B	1791	96.9	96.8	0.86	0.83	117	6.4	41.1	5973	0.7	2.5	26.5	6320	85
1200	AMD 450M4R B	1791	97.0	96.9	0.86	0.83	126	6.4	44.9	6399	0.7	2.4	28.4	6530	85
1220	AMD 450M4R B	1793	97.0	96.8	0.88	0.86	125	6.5	36.4	6498	0.7	2.3	36.2	6630	85

HV Flameproof motors, AMD Rg IIB/IIC

Technical data for totally enclosed squirrel cage three phase motors

6600 V, 60 Hz

IP55 – IC411 – insulation class F, temperature rise class B

Output (kW)	Motor type	Speed (r/min)	Efficiency		Power factor		Current			Torque			Rotor inertia (kgm ²)	Motor weight (kg)	Sound pressure level L _p (dB(A))
			Full load 100%	3/4 load 75%	Full load 100%	3/4 load 75%	I _N (A)	I _S I _N (pu)	I ₀ (A)	T _N (Nm)	T _S T _N (pu)	T _{max} T _N (pu)			
1800 r/min = 4 poles			6600 V 60 Hz												
1320	AMD 500S4R B	1791	96.9	96.7	0.87	0.84	137	6.4	47.4	7039	0.7	2.6	40.5	8290	86
1480	AMD 500S4R B	1792	97.1	96.9	0.86	0.83	154	6.5	55.1	7887	0.6	2.6	44.0	8680	86
1550	AMD 500M4R B	1792	97.1	97.0	0.88	0.85	159	6.4	52.6	8261	0.6	2.6	46.6	9170	86
1650	AMD 500M4R B	1792	97.2	97.1	0.87	0.84	171	6.5	59.1	8792	0.6	2.6	50.3	9520	86
1700	AMD 500M4R B	1794	97.2	97.0	0.90	0.88	170	6.5	44.4	9050	0.6	2.3	67.5	9850	86
1200 r/min = 6 poles			6600 V 60 Hz												
160	AMD 355L6R B	1186	94.2	93.8	0.79	0.74	19	5.9	9.0	1288	1.0	2.7	5.7	2380	78
180	AMD 355L6R B	1184	94.2	94.0	0.81	0.76	21	5.3	9.0	1452	0.9	2.4	5.7	2380	78
200	AMD 355L6R B	1186	94.5	94.4	0.82	0.78	23	4.8	9.2	1610	0.7	2.1	5.6	2380	78
225	AMD 355L6R B	1186	94.9	94.8	0.82	0.77	25	4.9	10.6	1811	0.7	2.2	5.7	2420	78
250	AMD 355L6R B	1186	95.0	94.9	0.82	0.77	28	5.3	11.8	2013	0.9	2.2	6.2	2500	78
280	AMD 355L6R B	1188	95.3	95.1	0.80	0.74	32	5.7	15.0	2251	0.9	2.4	6.5	2570	78
310	AMD 355L6R B	1189	95.6	95.5	0.80	0.75	35	5.4	16.0	2490	0.8	2.2	7.0	2690	78
360	AMD 355L6R B	1191	95.9	95.8	0.82	0.77	40	5.6	16.8	2885	0.8	2.2	9.1	2780	78
400	AMD 400L6R B	1191	96.0	95.8	0.81	0.76	45	5.7	19.5	3208	0.8	2.3	11.7	3580	80
450	AMD 400L6R B	1191	96.1	95.9	0.81	0.76	51	6.0	22.4	3609	0.9	2.4	13.5	3800	80
515	AMD 400L6R B	1191	96.3	96.1	0.81	0.76	58	5.9	25.5	4129	0.9	2.3	14.5	3980	80
575	AMD 400L6R B	1195	96.7	96.5	0.82	0.77	64	5.9	26.7	4597	0.7	2.2	18.9	4080	80
630	AMD 450M6R B	1191	96.1	96.1	0.86	0.83	66	5.9	22.8	5053	0.8	2.3	25.3	5320	83
710	AMD 450M6R B	1192	96.3	96.3	0.85	0.81	76	5.9	28.3	5689	0.7	2.3	27.3	5480	83
800	AMD 450M6R B	1192	96.5	96.5	0.85	0.81	86	5.9	31.7	6409	0.7	2.3	30.9	5740	83
900	AMD 450M6R B	1193	96.7	96.6	0.85	0.81	96	6.0	36.3	7207	0.7	2.3	35.7	6090	83
1000	AMD 450M6R B	1193	96.7	96.6	0.83	0.79	109	5.9	43.8	8004	0.7	2.4	41.7	6480	83
1100	AMD 450M6R B	1195	96.9	96.9	0.88	0.85	113	6.1	34.6	8790	0.6	2.2	54.3	6730	83
1150	AMD 500S6R B	1193	96.9	96.8	0.86	0.83	121	6.0	42.4	9207	0.7	2.3	56.9	8390	84
1250	AMD 500S6R B	1193	96.9	96.9	0.86	0.83	131	6.0	45.2	10008	0.7	2.3	62.9	8760	84
1320	AMD 500M6R B	1193	96.9	96.9	0.85	0.81	140	6.0	51.7	10568	0.7	2.3	67.0	9250	84
1450	AMD 500M6R B	1193	97.1	97.0	0.84	0.81	155	6.0	59.3	11604	0.7	2.4	74.3	9740	84
1550	AMD 500M6R B	1195	97.2	97.1	0.85	0.83	163	6.0	55.2	12386	0.8	2.1	94.0	10040	84
980 r/min = 8 poles			6600 V 60 Hz												
180	AMD 400L8R B	890	94.5	94.4	0.77	0.71	22	4.6	10.6	1932	0.8	2.0	9.5	3200	70
200	AMD 400L8R B	891	94.9	94.8	0.76	0.71	24	4.5	11.7	2143	0.7	1.9	9.7	3260	70
225	AMD 400L8R B	892	95.1	95.0	0.76	0.70	27	4.7	13.5	2410	0.7	2.0	10.6	3390	70
250	AMD 400L8R B	892	95.3	95.1	0.75	0.69	31	5.0	15.9	2677	0.9	2.1	11.8	3530	70
280	AMD 400L8R B	892	95.5	95.3	0.76	0.70	34	4.9	17.0	2998	0.8	2.0	12.7	3670	70
330	AMD 400L8R B	892	95.7	95.5	0.75	0.69	40	5.1	20.6	3532	0.8	2.1	14.8	3960	70
360	AMD 400L8R B	893	95.9	95.7	0.78	0.72	42	5.8	20.9	3848	0.8	2.5	18.1	4000	70
400	AMD 450M8R B	889	95.3	95.5	0.84	0.82	44	4.6	15.0	4296	0.7	1.9	26.1	5310	80
450	AMD 450M8R B	890	95.5	95.6	0.83	0.80	49	4.9	18.1	4829	0.8	2.0	26.0	5310	80
500	AMD 450M8R B	892	95.8	95.8	0.82	0.78	56	5.1	22.4	5355	0.8	2.0	26.4	5370	80

HV Flameproof motors, AMD Rg IIB/IIC

Technical data for totally enclosed squirrel cage three phase motors

6600 V, 60 Hz

IP55 – IC411 – insulation class F, temperature rise class B

Output (kW)	Motor type	Speed (r/min)	Efficiency		Power factor		Current			Torque			Rotor inertia (kgm ²)	Motor weight (kg)	Sound pressure level L _p (dB(A))
			Full load 100%	3/4 load 75%	Full load 100%	3/4 load 75%	I _N (A)	I _s I _N (pu)	I ₀ (A)	T _N (Nm)	T _s T _N (pu)	T _{max} T _N (pu)			
900 r/min = 8 poles		6600 V 60 Hz													
560	AMD 450M8R B	892	95.9	95.8	0.80	0.75	64	6.0	29.6	5994	1.0	2.4	29.9	5580	80
630	AMD 450M8R B	892	96.1	96.0	0.80	0.75	72	6.0	33.0	6741	1.0	2.4	33.5	5840	80
710	AMD 450M8R B	893	96.2	96.1	0.81	0.76	80	5.9	35.8	7597	1.0	2.4	38.6	6200	80
780	AMD 450M8R B	893	96.2	96.1	0.80	0.74	89	6.0	41.5	8336	0.9	2.4	43.9	6560	80
850	AMD 450M8R B	896	96.6	96.5	0.81	0.77	95	6.0	40.7	9062	0.7	2.3	55.4	6770	80
900	AMD 500S8R B	894	96.2	96.0	0.80	0.74	103	6.0	47.3	9613	0.9	2.4	59.7	8420	81
1000	AMD 500S8R B	894	96.3	96.2	0.80	0.75	113	6.0	51.0	10681	0.9	2.4	66.0	8810	81
1100	AMD 500M8R B	894	96.5	96.3	0.80	0.75	125	6.0	57.6	11744	0.9	2.4	71.4	9460	81
1150	AMD 500M8R B	894	96.4	96.2	0.78	0.72	134	6.0	65.5	12277	0.9	2.4	76.7	9740	81
1200	AMD 500M8R B	896	97.0	97.0	0.83	0.79	131	5.9	52.3	12784	0.7	2.2	96.5	10020	81
720 r/min = 10 poles		6600 V 60 Hz													
315	AMD 450M10R B	707	94.5	94.9	0.78	0.73	37	4.2	16.6	4252	0.8	1.9	27.0	5310	80
355	AMD 450M10R B	712	95.1	95.3	0.75	0.69	43	4.5	21.8	4764	0.7	2.0	26.0	5300	80
400	AMD 450M10R B	712	95.3	95.5	0.76	0.70	48	4.4	23.3	5363	0.8	1.8	27.6	5410	80
450	AMD 450M10R B	713	95.5	95.7	0.76	0.71	54	4.4	26.1	6030	0.7	1.8	30.7	5650	80
500	AMD 450M10R B	713	95.7	95.8	0.76	0.71	60	4.5	28.9	6698	0.8	1.9	34.2	5900	80
560	AMD 450M10R B	713	95.8	95.9	0.76	0.70	68	4.6	33.2	7499	0.8	1.9	38.4	6190	80
630	AMD 450M10R B	714	96.0	96.0	0.75	0.69	77	4.9	39.1	8431	0.8	2.0	43.9	6560	80
670	AMD 450M10R B	716	96.2	96.2	0.77	0.72	79	4.8	36.3	8936	0.7	1.9	56.4	6770	80
725	AMD 500S10R B	715	96.0	95.9	0.74	0.67	89	5.6	48.4	9689	1.0	2.3	61.8	8460	81
780	AMD 500S10R B	715	96.1	96.0	0.74	0.67	96	5.8	52.3	10423	1.1	2.4	67.9	8800	81
880	AMD 500M10R B	714	96.2	96.1	0.76	0.70	105	5.6	52.7	11765	1.0	2.2	78.4	9700	81
980	AMD 500M10R B	716	96.5	96.5	0.78	0.74	114	5.3	50.6	13068	0.8	1.9	95.6	9950	81
600 r/min = 12 poles		6600 V 60 Hz													
250	AMD 450M12R B	591	93.8	93.8	0.71	0.65	33	3.9	17.4	4041	0.8	1.8	27.0	5340	80
275	AMD 450M12R B	592	94.1	94.1	0.72	0.66	36	3.8	18.7	4439	0.7	1.8	28.3	5450	80
315	AMD 450M12R B	592	94.3	94.3	0.72	0.66	41	3.9	21.3	5085	0.7	1.8	31.8	5690	80
355	AMD 450M12R B	592	94.5	94.5	0.72	0.66	46	3.9	23.7	5728	0.7	1.8	37.5	6080	80
430	AMD 450M12R B	593	94.9	94.8	0.72	0.66	55	3.9	28.5	6928	0.7	1.8	43.8	6540	80
470	AMD 450M12R B	594	95.2	95.2	0.74	0.69	59	4.0	28.3	7554	0.6	1.8	55.3	6770	80
500	AMD 500S12R B	594	95.1	94.9	0.72	0.66	64	4.2	33.6	8034	0.7	1.9	53.9	8060	81
550	AMD 500S12R B	595	95.2	94.9	0.71	0.65	71	4.4	38.8	8832	0.7	2.0	60.1	8420	81
610	AMD 500M12R B	595	95.2	94.9	0.71	0.64	79	4.6	44.5	9790	0.8	2.1	69.5	9240	81
640	AMD 500M12R B	595	95.2	95.0	0.73	0.66	81	4.5	43.2	10274	0.8	2.0	76.7	9640	81
710	AMD 500M12R B	596	95.5	95.3	0.75	0.69	87	4.7	43.4	11374	0.6	2.0	95.2	9920	81

HV Flameproof motors, AMD Rg IIB/IIC

Technical data for totally enclosed squirrel cage three phase motors

6600 V, 60 Hz

IP55 – IC411 – insulation class F, temperature rise class B

Output (kW)	Motor type	Speed (r/min)	Efficiency		Power factor		Current			Torque			Rotor inertia (kgm ²)	Motor weight (kg)	Sound pressure level <i>L_p</i> (dB(A))
			Full load 100%	3/4 load 75%	Full load 100%	3/4 load 75%	<i>I_N</i> (A)	<i>I_s</i> <i>I_N</i> (pu)	<i>I₀</i> (A)	<i>T_N</i> (Nm)	<i>T_s</i> <i>T_N</i> (pu)	<i>T_{max}</i> <i>T_N</i> (pu)			
510 r/min = 14 poles			6600 V 60 Hz												
225	AMD 450M14R B	511	93.9	93.5	0.66	0.59	32	3.9	19.1	4208	0.6	1.8	39.7	5810	80
280	AMD 450M14R B	510	94.0	93.7	0.66	0.59	39	3.9	23.6	5239	0.6	1.8	43.7	6050	80
350	AMD 450M14R B	511	94.3	93.8	0.64	0.57	51	4.2	32.1	6543	0.7	2.0	55.6	6750	80
430	AMD 500S14R B	511	94.8	94.3	0.68	0.61	59	4.2	34.3	8043	0.7	1.9	83.4	9070	81
530	AMD 500M14R B	511	95.0	94.5	0.66	0.59	73	4.4	44.3	9911	0.7	2.0	95.0	9970	81
450 r/min = 16 poles			6600 V 60 Hz												
430	AMD 500S16R B	447	94.6	94.2	0.68	0.61	59	3.9	33.3	9194	0.6	1.8	108.8	9090	81
400 r/min = 18 poles			6600 V 60 Hz												
325	AMD 500S18R B	396	93.3	92.8	0.62	0.54	49	4.0	32.3	7837	0.9	2.0	107.5	9030	81

HV Flameproof motors, AMD T IIB

Technical data for totally enclosed squirrel cage three phase motors

6000 V, 50 Hz

IP55 – IC511 – insulation class F, temperature rise class B

Output (kW)	Motor type	Speed (r/min)	Efficiency		Power factor		Current			Torque			Rotor inertia (kgm ²)	Motor weight (kg)	Sound pressure level L _p (dB(A))
			Full load 100%	3/4 load 75%	Full load 100%	3/4 load 75%	I _N (A)	I _S I _N (pu)	I ₀ (A)	T _N (Nm)	T _S T _N (pu)	T _{max} T _N (pu)			
3000 r/min = 2 poles			6000 V 50 Hz												
500	AMD 500L2T	2975	94.3	94.2	0.91	0.90	55	5.2	11.5	1605	0.6	2.2	5.8	4000	83
560	AMD 500L2T	2976	94.7	94.5	0.91	0.91	62	5.4	12.3	1797	0.7	2.3	6.3	3980	83
630	AMD 500L2T	2972	94.6	94.6	0.91	0.91	69	4.8	12.3	2024	0.6	2.0	6.3	3980	83
710	AMD 500L2T	2971	94.8	95.0	0.92	0.92	78	4.7	12.5	2283	0.6	2.0	6.9	4480	83
800	AMD 500L2T	2976	95.3	95.4	0.91	0.91	87	5.4	16.8	2568	0.7	2.2	7.4	4400	83
900	AMD 500L2T	2978	95.6	95.7	0.92	0.91	98	5.8	18.8	2886	0.8	2.3	8.1	4920	83
1000	AMD 500L2T	2978	95.9	96.0	0.92	0.91	108	5.9	21.0	3206	0.8	2.3	8.5	5120	83
1120	AMD 560L2T	2983	96.1	96.0	0.91	0.90	122	6.2	26.2	3586	0.7	2.5	13.2	5840	83
1250	AMD 560L2T	2981	96.1	96.1	0.92	0.91	135	5.9	25.0	4005	0.7	2.4	14.3	6060	83
1400	AMD 560L2T	2981	96.3	96.3	0.91	0.91	151	6.1	29.0	4485	0.8	2.5	15.0	6280	83
1450	AMD 630M2T	2984	95.5	95.3	0.91	0.90	159	5.7	31.0	4640	0.7	2.3	23.1	7570	85
1600	AMD 630M2T	2984	95.7	95.6	0.91	0.90	175	5.9	34.0	5120	0.8	2.3	24.5	7870	85
1800	AMD 630L2T	2983	96.0	95.9	0.91	0.91	196	5.8	34.4	5763	0.8	2.3	25.2	8150	85
2000	AMD 630L2T	2984	96.2	96.1	0.91	0.91	217	6.1	40.2	6400	0.8	2.4	28.1	8690	85
2150	AMD 630L2T	2985	96.4	96.3	0.91	0.90	234	6.1	44.1	6878	0.8	2.4	30.6	9200	85
2250	AMD 710M2T	2986	95.8	95.5	0.92	0.92	243	5.2	34.1	7196	0.4	2.2	51.3	11000	87
2500	AMD 710M2T	2988	96.1	95.8	0.93	0.92	267	7.2	49.4	7989	0.7	3.0	53.7	11370	87
2600	AMD 710X2T	2987	96.0	95.7	0.92	0.93	280	5.3	37.9	8313	0.4	2.2	63.1	13000	87
2900	AMD 710X2T	2988	96.2	95.9	0.92	0.92	311	5.9	48.8	9268	0.5	2.5	66.3	13390	87
3500	AMD 900L2T	2987	96.3	95.9	0.93	0.92	374	6.1	59.7	11189	0.5	2.7	94.5	18630	88
4000	AMD 900L2T	2984	96.5	96.2	0.93	0.93	426	5.1	53.3	12800	0.4	2.2	98.8	19120	88
4500	AMD 900L2T	2989	96.8	96.6	0.93	0.93	478	6.0	74.5	14376	0.5	2.6	105.8	19590	88

HV Flameproof motors, AMD T IIB

Technical data for totally enclosed squirrel cage three phase motors

6000 V, 50 Hz

IP55 – IC511 – insulation class F, temperature rise class B

Output (kW)	Motor type	Speed (r/min)	Efficiency		Power factor		Current			Torque			Rotor inertia (kgm ²)	Motor weight (kg)	Sound pressure level L _p (dB(A))
			Full load 100%	3/4 load 75%	Full load 100%	3/4 load 75%	I _N (A)	I _S I _N (pu)	I ₀ (A)	T _N (Nm)	T _S T _N (pu)	T _{max} T _N (pu)			
1500 r/min = 4 poles			6000 V 50 Hz												
630	AMD 500L4T	1486	95.1	95.2	0.90	0.89	71	5.2	16.1	4049	0.8	2.1	13.6	4700	81
700	AMD 500L4T	1486	95.2	95.4	0.90	0.90	78	5.2	17.2	4500	0.8	2.1	14.6	4600	81
800	AMD 500L4T	1486	95.4	95.7	0.90	0.90	89	5.2	19.5	5140	0.8	2.0	16.0	4790	81
900	AMD 500L4T	1486	95.6	95.8	0.90	0.90	100	5.4	22.0	5782	0.9	2.1	17.1	4980	81
1000	AMD 560L4T	1489	95.5	95.5	0.89	0.88	113	5.8	29.0	6414	0.9	2.2	23.3	5600	82
1120	AMD 560L4T	1489	95.6	95.7	0.89	0.88	126	5.5	31.5	7185	0.9	2.1	25.0	5840	82
1250	AMD 560L4T	1488	95.9	96.0	0.91	0.90	139	5.5	29.7	8021	0.8	2.1	27.0	6060	82
1400	AMD 560L4T	1489	96.1	96.2	0.91	0.90	154	5.7	32.1	8982	0.9	2.1	30.4	6490	82
1600	AMD 630L4T	1491	96.1	96.0	0.91	0.89	177	6.1	44.2	10248	0.8	2.4	40.6	7870	83
1800	AMD 630L4T	1490	96.2	96.2	0.91	0.91	197	6.0	42.7	11533	0.8	2.3	45.7	8420	83
2000	AMD 710M4T	1491	96.3	96.2	0.93	0.92	216	6.0	40.9	12811	0.7	2.4	70.3	10550	82
2250	AMD 710M4T	1491	96.4	96.4	0.92	0.92	243	6.2	48.2	14411	0.7	2.5	74.5	10930	82
2500	AMD 710M4T	1491	96.6	96.6	0.92	0.91	272	6.0	57.4	16011	0.7	2.4	78.4	11300	82
2800	AMD 710M4T	1491	96.6	96.7	0.91	0.91	305	5.9	63.8	17929	0.7	2.3	84.7	11650	82
3200	AMD 710L4T	1491	96.6	96.7	0.92	0.91	346	5.8	70.1	20500	0.7	2.3	94.0	12330	82
3550	AMD 710L4T	1491	96.8	96.8	0.92	0.92	382	6.1	75.4	22742	0.7	2.4	102.9	12980	82
4000	AMD 710X4T	1492	97.0	97.0	0.93	0.93	426	6.5	81.3	25607	0.7	2.6	148.4	14470	82
5000	AMD 900L4T	1494	97.3	97.2	0.93	0.93	533	5.8	91.3	31951	0.5	2.2	345.5	21820	85
6000	AMD 900L4T	1494	97.5	97.4	0.92	0.92	643	5.9	122.0	38340	0.6	2.3	357.6	22240	85
7000	AMD 900L4T	1495	97.6	97.6	0.91	0.90	758	6.0	168.7	44727	0.6	2.3	366.7	22650	85
7500	AMD 900L4T	1494	98.1	98.2	0.91	0.90	809	5.9	175.7	47930	0.6	2.3	379.9	23050	85
1000 r/min = 6 poles			6000 V 50 Hz												
880	AMD 560L6T	990	95.7	96.1	0.87	0.86	101	4.9	25.9	8489	0.9	1.7	37.2	6700	81
1000	AMD 560L6T	991	96.0	96.3	0.87	0.85	116	5.5	33.5	9639	1.1	2.0	37.2	6700	81
1120	AMD 630L6T	993	95.8	95.9	0.88	0.87	127	5.9	36.0	10776	1.1	2.1	51.0	7870	80
1250	AMD 630L6T	992	95.9	96.0	0.88	0.87	142	6.0	39.9	12028	1.1	2.1	54.2	8150	80
1400	AMD 630L6T	992	96.0	96.2	0.89	0.88	157	5.9	39.3	13476	1.1	2.1	63.9	8950	80
1600	AMD 710M6T	993	96.2	96.3	0.90	0.89	178	5.9	41.2	15390	0.9	2.2	102.9	10930	79
1800	AMD 710M6T	993	96.4	96.5	0.90	0.89	200	6.0	47.9	17313	0.9	2.2	108.9	11300	79
2000	AMD 710M6T	992	96.4	96.6	0.91	0.90	220	5.8	46.2	19248	1.0	2.1	121.5	12000	79
2250	AMD 710L6T	993	96.6	96.8	0.91	0.90	247	5.9	50.0	21648	1.0	2.1	140.4	12980	79
2500	AMD 710L6T	993	96.7	96.9	0.90	0.89	276	6.3	63.3	24044	1.1	2.3	140.1	12980	79
2800	AMD 710X6T	995	97.1	97.2	0.90	0.89	307	6.1	69.8	26873	0.8	2.2	206.0	14810	79
3150	AMD 900L6T	996	97.2	97.2	0.90	0.89	348	5.7	83.3	30191	0.6	2.1	377.1	20960	86
3550	AMD 900L6T	996	97.3	97.3	0.90	0.89	391	5.6	90.1	34033	0.6	2.0	391.2	21390	86
4000	AMD 900L6T	996	97.4	97.5	0.90	0.90	440	5.4	93.8	38360	0.6	1.9	419.4	22240	86
4500	AMD 900L6T	996	97.5	97.5	0.90	0.89	495	5.6	110.4	43151	0.7	2.0	432.4	22650	86
4800	AMD 900L6T	996	97.5	97.6	0.89	0.88	530	6.1	131.7	46014	0.7	2.2	432.4	22650	86

HV Flameproof motors, AMD T IIB

Technical data for totally enclosed squirrel cage three phase motors

6000 V, 50 Hz

IP55 – IC511 – insulation class F, temperature rise class B

Output (kW)	Motor type	Speed (r/min)	Efficiency		Power factor		Current			Torque			Rotor inertia (kgm ²)	Motor weight (kg)	Sound pressure level L _p (dB(A))
			Full load 100%	3/4 load 75%	Full load 100%	3/4 load 75%	I _N (A)	I _S I _N (pu)	I ₀ (A)	T _N (Nm)	T _S T _N (pu)	T _{max} T _N (pu)			
750 r/min = 8 poles															
6000 V 50 Hz															
630	AMD 560L8T	742	95.2	95.6	0.86	0.84	74	5.1	23.5	8107	0.9	1.9	32.8	5840	81
710	AMD 560L8T	742	95.4	95.7	0.85	0.83	84	5.3	27.5	9134	1.0	1.9	35.1	6060	81
760	AMD 560L8T	743	95.6	95.8	0.85	0.83	90	5.4	30.0	9770	1.0	2.0	39.6	6490	81
800	AMD 630L8T	743	95.1	95.3	0.86	0.83	94	5.5	30.3	10289	1.1	2.1	50.3	7270	82
900	AMD 630L8T	742	95.4	95.6	0.86	0.84	105	5.4	32.7	11576	1.1	2.0	57.7	7870	82
1030	AMD 630L8T	743	95.6	95.8	0.86	0.84	120	5.6	37.3	13246	1.1	2.1	65.1	8420	82
1200	AMD 710M8T	745	96.4	96.4	0.86	0.84	139	6.0	44.9	15382	1.0	2.2	127.2	11300	74
1400	AMD 710M8T	743	96.2	96.4	0.87	0.86	160	5.5	44.6	17991	0.9	2.1	127.3	11300	74
1600	AMD 710M8T	743	96.4	96.6	0.88	0.87	182	5.2	45.9	20554	0.9	1.9	143.1	12000	74
1800	AMD 710L8T	745	96.6	96.7	0.87	0.85	206	6.0	61.9	23087	1.1	2.2	165.4	12980	74
2000	AMD 710X8T	745	96.7	96.7	0.89	0.88	224	5.8	56.8	25627	0.7	2.3	203.8	15140	74
2250	AMD 710X8T	745	96.7	96.8	0.89	0.88	252	5.6	62.8	28841	0.7	2.2	212.0	15470	74
2600	AMD 900M8T	746	97.1	97.2	0.89	0.89	289	5.1	66.2	33282	0.6	1.9	324.3	20960	80
3150	AMD 900M8T	746	97.1	97.3	0.89	0.88	351	5.3	86.9	40311	0.6	2.0	339.9	21390	80
3500	AMD 900L8T	746	97.1	97.3	0.89	0.88	389	5.3	96.3	44812	0.6	2.0	361.4	22240	80
3800	AMD 900L8T	746	97.2	97.4	0.89	0.88	422	5.6	107.0	48643	0.7	2.1	398.7	23450	80
600 r/min = 10 poles															
6000 V 50 Hz															
455	AMD 560L10T	593	94.2	94.4	0.77	0.73	60	4.4	26.0	7332	0.9	1.7	36.9	6280	80
500	AMD 560L10T	592	94.2	94.4	0.77	0.73	66	4.4	28.6	8065	0.9	1.7	38.4	6490	80
650	AMD 630M10T	595	95.4	95.5	0.81	0.77	81	5.4	34.2	10434	1.0	2.1	53.9	7570	82
730	AMD 630M10T	595	95.6	95.7	0.81	0.77	90	5.5	38.4	11715	1.0	2.1	61.3	8150	82
800	AMD 630M10T	595	95.8	95.8	0.81	0.77	99	5.6	42.7	12832	1.0	2.2	72.4	8950	82
1000	AMD 710M10T	596	96.0	96.1	0.85	0.82	119	5.4	40.0	16029	0.9	1.9	137.8	10930	74
1120	AMD 710M10T	596	96.1	96.2	0.84	0.82	133	5.5	45.7	17953	1.0	1.9	146.4	11300	74
1250	AMD 710L10T	596	96.3	96.3	0.84	0.81	149	5.8	53.3	20018	1.0	2.0	180.3	12660	74
1400	AMD 710L10T	596	96.4	96.4	0.83	0.80	167	6.0	62.8	22415	1.0	2.1	197.2	13290	74
1600	AMD 710X10T	595	96.2	96.4	0.86	0.85	186	5.3	52.2	25687	0.9	1.9	229.2	14810	74
1800	AMD 710X10T	595	96.3	96.5	0.86	0.85	208	5.6	60.6	28889	1.0	2.0	258.8	15790	74
2000	AMD 900M10T	597	96.9	96.9	0.86	0.85	230	5.5	66.9	31980	0.7	1.9	512.3	20960	75
2240	AMD 900M10T	597	97.0	97.0	0.86	0.84	260	5.4	79.4	35810	0.7	1.9	549.1	21820	75
2800	AMD 900L10T	597	97.1	97.2	0.85	0.83	325	5.4	99.6	44772	0.7	1.8	588.7	22650	75
3150	AMD 900L10T	597	97.1	97.2	0.86	0.84	365	5.5	108.1	50377	0.7	1.9	630.1	23450	75

HV Flameproof motors, AMD T IIB

Technical data for totally enclosed squirrel cage three phase motors

6000 V, 50 Hz

IP55 – IC511 – insulation class F, temperature rise class B

Output (kW)	Motor type	Speed (r/min)	Efficiency		Power factor		Current			Torque			Rotor inertia (kgm ²)	Motor weight (kg)	Sound pressure level <i>L_p</i> (dB(A))
			Full load 100%	3/4 load 75%	Full load 100%	3/4 load 75%	<i>I_N</i> (A)	<i>I_S</i> <i>I_N</i> (pu)	<i>I₀</i> (A)	<i>T_N</i> (Nm)	<i>T_S</i> <i>T_N</i> (pu)	<i>T_{max}</i> <i>T_N</i> (pu)			
500 r/min = 12 poles		6000 V 50 Hz													
280	AMD 560L12T	494	93.0	93.0	0.74	0.69	39	4.2	19.1	5410	0.8	1.8	30.4	5600	80
315	AMD 560L12T	494	93.3	93.3	0.75	0.70	43	4.3	21.1	6084	0.9	1.8	34.9	6060	80
355	AMD 560L12T	495	93.6	93.4	0.74	0.68	49	4.5	25.3	6851	0.9	2.0	39.5	6490	80
450	AMD 630M12T	494	94.0	94.2	0.78	0.74	59	4.1	25.9	8703	0.8	1.8	49.5	7270	82
500	AMD 630M12T	494	94.1	94.3	0.78	0.74	66	4.1	28.7	9671	0.7	1.7	53.1	7570	82
560	AMD 630M12T	494	94.3	94.5	0.79	0.75	73	4.1	30.5	10834	0.8	1.8	60.5	8150	82
610	AMD 630M12T	494	94.5	94.6	0.79	0.74	79	4.3	33.9	11795	0.8	1.8	67.8	8690	82
730	AMD 710M12T	496	95.6	95.7	0.82	0.78	89	5.2	36.5	14062	0.8	2.2	144.4	11300	74
800	AMD 710M12T	496	95.7	95.8	0.82	0.77	98	5.4	41.6	15406	0.8	2.2	153.0	11650	74
900	AMD 710M12T	495	95.6	95.8	0.83	0.79	109	4.8	41.6	17356	0.7	2.0	153.0	11650	74
1000	AMD 710L12T	496	95.9	96.0	0.83	0.78	122	5.4	49.8	19259	0.8	2.2	187.6	12980	74
1250	AMD 710X12T	496	95.9	96.1	0.85	0.83	147	5.3	48.5	24083	0.9	2.0	240.3	15140	74
1400	AMD 710X12T	496	95.9	96.1	0.85	0.83	165	5.2	53.2	26982	0.9	1.9	260.2	15790	74
1600	AMD 900M12T	497	96.5	96.6	0.84	0.81	191	5.2	66.0	30743	0.7	1.9	508.6	20960	71
2000	AMD 900L12T	497	96.6	96.7	0.84	0.81	238	5.2	80.9	38440	0.7	1.9	568.2	22240	71
2500	AMD 900L12T	497	96.8	96.8	0.82	0.80	302	5.1	108.9	48041	0.7	1.9	624.6	23450	71
425 r/min = 14 poles		6000 V 50 Hz													
200	AMD 560L14T	421	91.1	91.2	0.72	0.66	29	3.7	15.8	4536	0.8	1.8	29.0	5600	80
250	AMD 560L14T	421	91.6	91.6	0.71	0.65	37	3.8	20.1	5668	0.8	1.9	33.3	6060	80
300	AMD 560L14T	421	92.2	92.3	0.72	0.66	43	3.9	22.8	6805	0.9	1.9	39.8	6700	80
380	AMD 630M14T	423	93.2	93.2	0.72	0.66	54	4.0	28.5	8583	0.8	1.9	54.3	7870	82
420	AMD 630M14T	423	93.6	93.7	0.73	0.67	59	4.0	30.7	9475	0.7	1.9	62.4	8420	82
470	AMD 630M14T	423	93.9	93.9	0.73	0.68	66	3.7	32.4	10609	0.6	1.7	69.8	8950	82
560	AMD 710M14T	424	94.9	94.9	0.77	0.70	74	4.8	37.5	12603	0.9	2.2	126.0	11300	74
630	AMD 710M14T	424	94.9	94.9	0.76	0.70	84	4.8	42.7	14180	0.9	2.2	133.5	11650	74
710	AMD 710M14T	424	95.0	95.1	0.77	0.71	93	4.8	45.8	15988	0.9	2.2	148.7	12330	74
800	AMD 710L14T	424	95.1	95.1	0.77	0.72	105	4.8	51.3	18012	0.9	2.2	163.8	12980	74
900	AMD 710L14T	424	95.4	95.5	0.78	0.73	116	5.0	55.3	20257	0.9	2.2	194.6	14180	74
1120	AMD 710X14T	425	95.6	95.7	0.82	0.78	138	4.7	55.1	25175	0.7	1.9	232.2	14810	74
1250	AMD 710X14T	425	95.7	95.9	0.81	0.77	155	4.9	63.7	28085	0.8	2.0	262.2	15790	74
1400	AMD 900M14T	426	96.3	96.3	0.83	0.79	169	4.9	63.9	31408	0.7	2.0	509.5	20960	68
1600	AMD 900M14T	426	96.4	96.4	0.81	0.77	197	5.5	83.3	35871	0.8	2.2	549.5	21820	68
1800	AMD 900M14T	426	96.4	96.3	0.77	0.71	234	5.7	119.2	40346	0.8	2.5	579.5	22650	68

HV Flameproof motors, AMD T IIB

Technical data for totally enclosed squirrel cage three phase motors

6000 V, 50 Hz

IP55 – IC511 – insulation class F, temperature rise class B

Output (kW)	Motor type	Speed (r/min)	Efficiency		Power factor		Current			Torque			Rotor inertia (kgm ²)	Motor weight (kg)	Sound pressure level L _p (dB(A))
			Full load 100%	3/4 load 75%	Full load 100%	3/4 load 75%	I _N (A)	I _S I _N (pu)	I ₀ (A)	T _N (Nm)	T _S T _N (pu)	T _{max} T _N (pu)			
375 r/min = 16 poles			6000 V 50 Hz												
280	AMD 630M16T	368	92.4	92.3	0.69	0.63	42	3.5	23.3	7261	0.8	1.8	60.0	8420	82
315	AMD 630M16T	366	92.1	92.5	0.72	0.67	46	3.0	21.7	8209	0.6	1.5	63.6	8690	82
355	AMD 630M16T	368	92.5	92.6	0.70	0.64	53	3.3	28.3	9218	0.7	1.7	70.5	9200	82
450	AMD 710M16T	370	94.2	94.5	0.76	0.72	60	4.0	26.9	11600	0.8	1.7	127.2	11300	74
500	AMD 710M16T	371	94.6	94.8	0.75	0.70	68	4.1	31.7	12880	0.8	1.8	134.8	11650	74
560	AMD 710M16T	371	94.8	95.0	0.75	0.70	76	4.1	35.9	14422	0.8	1.8	150.0	12330	74
630	AMD 710L16T	371	95.0	95.1	0.75	0.70	85	4.2	40.3	16221	0.8	1.8	172.8	13290	74
680	AMD 710L16T	372	95.1	95.0	0.71	0.64	97	4.9	55.6	17472	1.0	2.2	180.5	13590	74
710	AMD 710L16T	371	95.2	95.2	0.74	0.68	97	4.3	49.2	18266	0.8	1.9	195.7	14180	74
900	AMD 710X16T	371	95.1	95.3	0.78	0.74	117	4.1	48.8	23164	0.7	1.7	242.5	15140	74
1000	AMD 710X16T	371	95.2	95.4	0.78	0.74	130	4.0	53.5	25740	0.7	1.7	262.5	15790	74
1250	AMD 900M16T	373	96.2	96.1	0.72	0.66	173	4.6	94.7	32026	0.7	2.1	508.8	20960	74
1320	AMD 900L16T	373	96.1	96.0	0.73	0.67	181	4.6	95.0	33818	0.7	2.0	568.8	22240	74
1400	AMD 900L16T	373	96.3	96.2	0.73	0.66	193	4.7	104.3	35860	0.7	2.1	608.7	23050	74
335 r/min = 18 poles			6000 V 50 Hz												
710	AMD 900M18T	331	95.6	95.3	0.67	0.60	107	4.6	64.8	20463	0.8	2.2	504.8	20960	63
900	AMD 900L18T	331	95.7	95.2	0.64	0.56	142	5.0	93.1	25927	0.9	2.4	564.3	22240	63
1000	AMD 900L18T	332	95.5	94.8	0.57	0.48	178	5.5	132.7	28780	1.2	2.9	604.0	23050	63

HV Flameproof motors, AMD T IIB

Technical data for totally enclosed squirrel cage three phase motors

10000 V, 50 Hz

IP55 – IC511 – insulation class F, temperature rise class B

Output (kW)	Motor type	Speed (r/min)	Efficiency		Power factor		Current			Torque			Rotor inertia (kgm ²)	Motor weight (kg)	Sound pressure level L _p (dB(A))
			Full load 100%	3/4 load 75%	Full load 100%	3/4 load 75%	I _N (A)	I _S I _N (pu)	I ₀ (A)	T _N (Nm)	T _S T _N (pu)	T _{max} T _N (pu)			
3000 r/min = 2 poles			10000 V 50 Hz												
400	AMD 500L2T	2980	93.7	93.3	0.91	0.90	27	5.8	6.1	1282	0.7	2.4	6.8	4480	83
450	AMD 500L2T	2980	94.1	93.7	0.91	0.91	30	5.8	6.4	1442	0.7	2.4	7.3	4400	83
500	AMD 500L2T	2980	94.4	94.1	0.91	0.91	33	5.8	7.0	1602	0.7	2.3	7.8	4600	83
560	AMD 500L2T	2980	94.4	94.3	0.91	0.90	37	5.7	8.3	1795	0.7	2.3	7.9	4600	83
615	AMD 560L2T	2986	94.7	94.3	0.90	0.88	41	6.2	10.5	1967	0.8	2.5	10.4	5100	83
690	AMD 560L2T	2984	94.9	94.6	0.90	0.89	46	6.1	10.9	2208	0.8	2.4	10.4	5100	83
775	AMD 560L2T	2985	95.1	94.9	0.90	0.89	52	6.2	12.1	2480	0.8	2.5	11.3	5350	83
875	AMD 560L2T	2984	95.3	95.2	0.91	0.90	58	6.1	12.4	2800	0.8	2.4	12.2	5600	83
975	AMD 560L2T	2984	95.6	95.5	0.91	0.90	64	5.9	13.8	3121	0.8	2.3	13.2	5840	83
1120	AMD 630L2T	2987	94.9	94.5	0.91	0.90	74	6.2	15.9	3581	0.7	2.5	22.7	7570	85
1250	AMD 630L2T	2987	95.2	94.8	0.91	0.90	83	6.3	17.8	3996	0.8	2.5	24.2	7870	85
1400	AMD 630L2T	2985	95.3	95.1	0.91	0.90	92	5.7	17.8	4479	0.7	2.3	24.2	7870	85
1600	AMD 710M2T	2989	95.0	94.4	0.92	0.92	104	6.3	18.6	5112	0.5	2.7	48.7	10630	87
1800	AMD 710M2T	2989	95.2	94.7	0.92	0.91	117	6.5	21.7	5750	0.5	2.7	51.1	11000	87
2000	AMD 710M2T	2988	95.5	95.1	0.93	0.92	129	6.3	20.7	6392	0.6	2.6	54.4	11370	87
2250	AMD 710X2T	2989	95.7	95.2	0.92	0.92	145	6.0	22.8	7189	0.5	2.5	63.1	13000	87
2500	AMD 710X2T	2989	95.9	95.5	0.93	0.92	161	6.1	24.9	7988	0.5	2.5	66.3	13390	87
3000	AMD 900L2T	2988	96.0	95.5	0.92	0.92	194	6.3	35.0	9587	0.5	2.7	93.8	18630	88
3550	AMD 900L2T	2989	96.2	95.9	0.92	0.92	229	6.4	40.6	11342	0.5	2.8	99.6	19120	88
1500 r/min = 4 poles			10000 V 50 Hz												
450	AMD 500L4T	1490	97.0	96.9	0.87	0.84	32	5.9	10.9	2884	0.8	2.5	13.2	5120	81
500	AMD 500L4T	1490	97.0	97.1	0.88	0.85	35	5.8	11.1	3205	0.7	2.4	13.5	5120	81
560	AMD 500L4T	1487	97.0	97.1	0.89	0.87	38	5.9	10.8	3596	0.9	2.3	13.6	4790	81
630	AMD 500L4T	1488	97.3	97.3	0.89	0.87	43	5.7	12.7	4043	0.8	2.2	13.5	4790	81
700	AMD 500L4T	1489	97.0	96.9	0.89	0.88	48	6.0	13.0	4491	1.0	2.2	14.8	4980	81
800	AMD 560L4T	1489	97.1	97.1	0.91	0.89	54	6.1	13.9	5131	0.9	2.3	26.9	5600	82
1250	AMD 630L4T	1491	97.1	97.2	0.90	0.89	84	6.0	21.0	8008	0.8	2.3	41.6	7570	83
1400	AMD 630L4T	1491	97.3	97.3	0.91	0.89	93	6.2	22.8	8969	0.9	2.3	44.7	7870	83
1600	AMD 710M4T	1490	96.7	96.7	0.91	0.91	106	5.4	19.6	10258	0.8	2.0	74.1	10930	82
1800	AMD 710M4T	1491	96.8	96.9	0.91	0.90	119	5.9	26.6	11531	0.8	2.3	73.5	10930	82
2000	AMD 710M4T	1490	96.6	96.7	0.92	0.92	131	5.5	24.0	12818	0.8	2.0	79.2	11300	82
2250	AMD 710M4T	1491	96.8	96.9	0.91	0.91	148	5.9	30.5	14406	0.8	2.2	84.4	11650	82
2500	AMD 710L4T	1490	96.9	97.0	0.92	0.92	163	5.4	28.3	16027	0.7	2.1	94.6	12000	82
2800	AMD 710L4T	1490	96.0	96.1	0.92	0.92	183	5.5	34.4	17940	0.7	2.1	100.1	12330	82
3000	AMD 710L4T	1491	96.2	96.2	0.92	0.91	196	5.9	39.6	19212	0.7	2.3	104.6	12660	82
3400	AMD 710X4T	1490	96.4	96.4	0.93	0.93	219	5.4	35.1	21786	0.6	2.2	140.0	14120	82
3600	AMD 710X4T	1491	95.4	95.6	0.93	0.93	231	6.2	41.3	23062	0.7	2.5	145.4	14470	82
3700	AMD 710X4T	1491	95.7	95.8	0.93	0.93	237	5.7	38.1	23705	0.7	2.3	152.2	14810	82
4250	AMD 900L4T	1494	95.9	95.8	0.92	0.92	274	5.9	49.2	27160	0.6	2.2	328.9	21390	85
5150	AMD 900L4T	1491	95.3	95.2	0.91	0.93	338	4.1	40.8	32976	0.4	1.5	340.9	21820	85
5150	AMD 900L4T	1491	95.5	95.4	0.91	0.93	338	4.1	40.8	32976	0.4	1.5	340.9	21820	85
5900	AMD 900L4T	1493	95.7	95.6	0.92	0.92	381	5.3	61.5	37727	0.5	2.0	353.0	22240	85

HV Flameproof motors, AMD T IIB

Technical data for totally enclosed squirrel cage three phase motors

10000 V, 50 Hz

IP55 – IC511 – insulation class F, temperature rise class B

Output (kW)	Motor type	Speed (r/min)	Efficiency		Power factor		Current			Torque			Rotor inertia (kgm ²)	Motor weight (kg)	Sound pressure level L _p (dB(A))
			Full load 100%	3/4 load 75%	Full load 100%	3/4 load 75%	I _N (A)	I _S I _N (pu)	I ₀ (A)	T _N (Nm)	T _S T _N (pu)	T _{max} T _N (pu)			
1000 r/min = 6 poles			10000 V 50 Hz												
630	AMD 560L6T	991	94.6	94.1	0.82	0.80	46	4.5	16.3	6072	0.7	1.7	26.8	5600	81
710	AMD 560L6T	990	94.8	94.4	0.83	0.81	52	4.4	17.0	6847	0.8	1.6	28.8	5840	81
800	AMD 560L6T	991	95.0	94.6	0.83	0.80	59	4.6	19.8	7707	0.8	1.7	31.1	6060	81
900	AMD 630L6T	993	95.1	95.1	0.87	0.85	63	5.9	19.7	8659	0.9	2.2	60.6	7570	80
1000	AMD 630L6T	992	95.3	95.4	0.88	0.87	68	5.9	19.6	9626	1.0	2.2	69.3	8150	80
1120	AMD 630L6T	992	95.4	95.6	0.89	0.87	76	5.7	21.1	10784	1.0	2.1	73.6	8420	80
1250	AMD 710M6T	993	95.8	95.9	0.90	0.89	84	5.6	20.0	12024	0.8	2.1	106.8	10160	79
1400	AMD 710M6T	993	96.0	96.0	0.90	0.89	94	5.8	23.1	13466	0.9	2.2	114.3	10550	79
1600	AMD 710M6T	993	96.2	96.3	0.90	0.90	106	5.8	24.0	15393	0.9	2.1	129.2	11300	79
1800	AMD 710L6T	993	96.3	96.4	0.90	0.90	120	5.7	26.2	17312	0.9	2.1	135.2	12660	79
2000	AMD 710L6T	993	96.4	96.5	0.90	0.90	133	5.7	29.3	19239	0.9	2.1	141.5	12980	79
2250	AMD 710X6T	993	96.6	96.8	0.91	0.91	147	5.8	29.3	21631	0.8	2.1	191.5	14810	79
2500	AMD 710X6T	994	96.7	96.9	0.91	0.91	164	5.7	31.7	24017	0.8	2.1	194.7	14810	79
2500	AMD 900L6T	996	97.0	96.9	0.90	0.89	166	5.6	38.9	23969	0.6	2.1	390.2	21390	86
3150	AMD 900L6T	996	97.1	97.1	0.90	0.90	207	5.8	45.5	30210	0.7	2.1	407.4	21820	86
3550	AMD 900L6T	996	97.1	97.2	0.90	0.89	234	5.9	54.8	34038	0.7	2.1	419.4	22240	86
4000	AMD 900L6T	996	97.3	97.3	0.89	0.88	266	6.2	68.9	38339	0.7	2.2	430.2	22650	86
750 r/min = 8 poles			10000 V 50 Hz												
650	AMD 630L8T	745	96.7	96.7	0.85	0.82	46	6.0	16.6	8332	1.0	2.2	55.6	7570	82
710	AMD 630L8T	745	96.8	96.9	0.86	0.83	50	5.8	17.5	9102	0.9	2.1	59.3	7870	82
850	AMD 630L8T	745	96.6	96.7	0.85	0.82	60	5.8	21.2	10896	0.9	2.1	66.7	8420	82
1000	AMD 710M8T	745	96.8	96.9	0.87	0.85	69	5.7	20.8	12826	0.9	2.1	112.5	10550	74
1120	AMD 710M8T	743	96.9	97.0	0.88	0.86	77	5.5	21.0	14386	0.9	2.0	126.9	11300	74
1250	AMD 710M8T	744	96.0	96.1	0.88	0.86	86	5.7	24.3	16052	1.0	2.1	134.4	11650	74
1400	AMD 710L8T	744	96.2	96.2	0.87	0.85	97	5.9	29.4	17970	1.0	2.2	141.5	12000	74
1600	AMD 710L8T	744	96.4	96.4	0.87	0.85	110	5.9	33.9	20537	1.0	2.2	137.0	12660	74
1800	AMD 710X8T	745	95.4	95.6	0.89	0.88	121	5.6	29.9	23068	0.7	2.2	203.8	15140	74
2000	AMD 710X8T	745	95.7	95.8	0.88	0.88	136	5.4	32.7	25624	0.7	2.0	214.2	15470	74
2000	AMD 900L8T	747	95.9	95.8	0.89	0.87	135	5.5	38.0	25583	0.6	2.2	333.0	21390	80
2500	AMD 900L8T	746	95.3	95.2	0.89	0.88	167	5.7	43.9	31990	0.6	2.2	361.4	22240	80

HV Flameproof motors, AMD T IIB

Technical data for totally enclosed squirrel cage three phase motors

10000 V, 50 Hz

IP55 – IC511 – insulation class F, temperature rise class B

Output (kW)	Motor type	Speed (r/min)	Efficiency		Power factor		Current			Torque			Rotor inertia (kgm ²)	Motor weight (kg)	Sound pressure level L _p (dB(A))
			Full load 100%	3/4 load 75%	Full load 100%	3/4 load 75%	I _N (A)	I _S I _N (pu)	I ₀ (A)	T _N (Nm)	T _S T _N (pu)	T _{max} T _N (pu)			
600 r/min = 10 poles			10000 V 50 Hz												
450	AMD 630M10T	596	95.5	95.4	0.81	0.76	34	5.4	15.0	7209	0.9	2.1	55.5	7570	82
500	AMD 630M10T	596	95.7	95.6	0.79	0.74	39	5.5	18.4	8009	0.9	2.2	55.0	7570	82
560	AMD 630M10T	596	94.6	94.1	0.80	0.75	43	5.4	19.9	8973	0.9	2.2	58.8	7870	82
630	AMD 710M10T	596	94.8	94.4	0.84	0.80	45	5.8	17.3	10091	0.9	2.2	113.8	10550	74
710	AMD 710M10T	596	95.0	94.6	0.84	0.80	51	5.8	19.3	11373	1.0	2.2	121.4	10930	74
800	AMD 710M10T	596	95.7	95.7	0.83	0.80	58	5.7	22.3	12814	0.9	2.2	128.6	11300	74
900	AMD 710M10T	596	95.8	95.8	0.82	0.78	66	5.8	26.6	14413	0.9	2.2	135.8	11650	74
1000	AMD 710L10T	596	95.6	95.8	0.84	0.81	72	5.8	26.0	16014	1.0	2.1	152.8	12330	74
1120	AMD 710L10T	597	95.9	95.9	0.84	0.80	81	5.9	30.7	17929	1.0	2.1	167.6	12980	74
1250	AMD 710X10T	596	95.9	96.0	0.86	0.84	87	5.8	28.1	20032	0.9	2.0	229.0	14810	74
1500	AMD 710X10T	596	96.1	96.2	0.86	0.84	104	6.7	34.4	24018	1.2	2.3	261.5	15790	74
1800	AMD 900M10T	597	96.6	96.7	0.87	0.86	124	4.9	31.9	28807	0.6	1.7	533.7	21390	75
2300	AMD 900L10T	597	96.8	96.9	0.87	0.86	158	5.2	42.0	36803	0.7	1.8	573.6	22240	75
2700	AMD 900L10T	597	96.9	97.0	0.85	0.83	189	6.0	62.1	43162	0.8	2.0	610.2	23050	75
500 r/min = 12 poles			10000 V 50 Hz												
315	AMD 630M12T	493	96.0	96.1	0.74	0.67	27	4.1	14.1	6099	0.7	2.0	39.1	7270	82
355	AMD 630M12T	492	96.2	96.2	0.75	0.70	29	4.0	14.4	6884	0.7	1.9	42.7	7570	82
400	AMD 630M12T	492	96.4	96.4	0.75	0.70	33	4.0	16.5	7760	0.8	1.9	42.7	7570	82
450	AMD 630M12T	494	95.4	95.6	0.75	0.70	37	3.9	17.9	8696	0.6	1.8	47.8	7870	82
500	AMD 710M12T	496	95.7	95.8	0.80	0.75	38	5.3	17.0	9618	0.8	2.3	113.9	10550	74
560	AMD 710M12T	496	95.9	95.8	0.80	0.75	42	5.3	19.1	10772	0.8	2.3	121.4	10930	74
630	AMD 710M12T	496	95.3	95.2	0.80	0.74	48	5.4	22.1	12118	0.8	2.3	129.0	11300	74
710	AMD 710M12T	496	95.5	95.4	0.83	0.79	52	5.0	20.0	13678	0.8	2.1	137.5	11650	74
800	AMD 710L12T	497	95.7	95.6	0.80	0.75	60	5.8	27.7	15382	0.9	2.4	160.0	12660	74
900	AMD 710L12T	496	94.6	94.1	0.82	0.78	66	5.7	28.0	17317	1.0	2.3	175.8	13290	74
1000	AMD 710L12T	496	94.8	94.4	0.82	0.78	74	5.6	31.2	19244	1.0	2.3	183.4	13590	74
1120	AMD 710X12T	496	95.0	94.6	0.85	0.81	80	5.4	29.0	21550	0.8	2.1	213.2	15140	74
1250	AMD 710X12T	496	95.9	96.1	0.84	0.81	89	5.3	32.7	24055	0.8	2.1	222.0	15470	74
1400	AMD 900M12T	497	96.0	96.1	0.83	0.80	102	5.0	37.2	26902	0.6	1.9	506.0	20960	71
1700	AMD 900L12T	497	96.2	96.2	0.82	0.77	125	5.6	51.2	32645	0.7	2.1	545.5	21820	71
2000	AMD 900L12T	497	96.4	96.4	0.82	0.77	147	5.6	59.7	38410	0.8	2.1	585.1	22650	71

HV Flameproof motors, AMD T IIB

Technical data for totally enclosed squirrel cage three phase motors

10000 V, 50 Hz

IP55 – IC511 – insulation class F, temperature rise class B

Output (kW)	Motor type	Speed (r/min)	Efficiency		Power factor		Current			Torque			Rotor inertia (kgm ²)	Motor weight (kg)	Sound pressure level L _p (dB(A))
			Full load 100%	3/4 load 75%	Full load 100%	3/4 load 75%	I _N (A)	I _S I _N (pu)	I ₀ (A)	T _N (Nm)	T _S T _N (pu)	T _{max} T _N (pu)			
430 r/min = 14 poles			10000 V 50 Hz												
500	AMD 710M14T	424	94.6	94.7	0.76	0.71	40	4.2	18.5	11256	0.7	1.8	120.2	11300	74
560	AMD 710M14T	424	94.6	94.8	0.77	0.72	45	4.0	19.8	12614	0.7	1.7	127.3	11650	74
630	AMD 710L14T	424	94.9	95.1	0.77	0.72	50	4.2	22.3	14184	0.7	1.8	148.5	12660	74
710	AMD 710L14T	425	95.2	95.1	0.75	0.69	58	4.7	29.2	15963	0.9	2.0	162.7	13290	74
800	AMD 710L14T	425	95.2	95.2	0.75	0.69	65	4.6	32.5	17990	0.9	2.0	176.8	13890	74
900	AMD 710X14T	425	95.0	95.1	0.81	0.76	67	5.4	29.0	20208	1.0	2.1	217.8	14810	74
1000	AMD 710X14T	426	95.1	94.9	0.79	0.73	77	5.3	36.8	22436	0.9	2.2	236.6	15470	74
1060	AMD 900M14T	426	95.4	95.6	0.83	0.79	78	4.5	28.6	23788	0.6	1.9	526.3	21390	68
1200	AMD 900L14T	426	95.7	95.8	0.81	0.77	89	5.2	37.7	26900	0.7	2.2	566.0	22240	68
1320	AMD 900L14T	426	95.9	95.8	0.80	0.75	99	5.5	44.8	29578	0.8	2.3	585.9	22650	68
375 r/min = 16 poles			10000 V 50 Hz												
400	AMD 710M16T	371	95.3	95.2	0.74	0.69	33	4.1	16.5	10291	0.8	1.8	134.8	11650	74
450	AMD 710M16T	371	95.5	95.4	0.75	0.70	37	4.0	17.8	11585	0.7	1.8	142.4	12000	74
500	AMD 710L16T	371	95.7	95.6	0.74	0.69	41	4.2	20.3	12864	0.8	1.8	165.2	12980	74
560	AMD 710L16T	371	94.4	94.5	0.74	0.69	46	4.2	23.0	14410	0.8	1.9	172.8	13290	74
630	AMD 710X16T	371	94.4	94.5	0.76	0.70	51	4.5	24.7	16195	0.8	1.9	215.6	14810	74
710	AMD 710X16T	372	94.5	94.6	0.75	0.69	58	4.6	29.1	18248	0.9	2.0	224.9	15140	74
800	AMD 710X16T	372	94.7	94.6	0.73	0.67	66	4.8	35.3	20553	0.9	2.1	234.2	15470	74
800	AMD 900M16T	373	95.3	95.2	0.73	0.66	66	5.0	36.3	20488	0.7	2.3	508.8	20960	74
900	AMD 900L16T	373	95.5	95.4	0.74	0.68	73	4.8	38.8	23054	0.7	2.2	548.8	21820	74
1180	AMD 900L16T	373	95.7	95.6	0.73	0.67	97	4.7	51.9	30229	0.7	2.1	588.7	22650	74
335 r/min = 18 poles			10000 V 50 Hz												
600	AMD 900M18T	331	94.6	94.1	0.64	0.56	57	4.7	37.2	17287	0.8	2.4	503.4	20960	63
700	AMD 900L18T	331	94.8	94.4	0.65	0.57	66	4.7	42.6	20169	0.8	2.3	562.8	22240	63
800	AMD 900L18T	331	95.0	94.6	0.66	0.58	74	4.8	47.3	23054	0.8	2.3	585.8	22650	63

HV Flameproof motors, AMD T IIB

Technical data for totally enclosed squirrel cage three phase motors

11000 V, 50 Hz

IP55 – IC511 – insulation class F, temperature rise class B

Output (kW)	Motor type	Speed (r/min)	Efficiency		Power factor		Current			Torque			Rotor inertia (kgm ²)	Motor weight (kg)	Sound pressure level L _p (dB(A))
			Full load 100%	3/4 load 75%	Full load 100%	3/4 load 75%	I _N (A)	I _S I _N (pu)	I ₀ (A)	T _N (Nm)	T _S T _N (pu)	T _{max} T _N (pu)			
3000 r/min = 2 poles		11000 V 50 Hz													
400	AMD 500L2T	2981	93.6	93.2	0.91	0.89	24	5.8	5.9	1281	0.7	2.4	6.7	4200	83
450	AMD 500L2T	2981	93.9	93.6	0.91	0.90	27	5.8	6.1	1442	0.7	2.4	7.3	4400	83
500	AMD 500L2T	2983	94.2	93.9	0.90	0.89	31	6.0	7.7	1601	0.7	2.4	7.7	4600	83
560	AMD 560L2T	2986	94.5	94.0	0.90	0.89	34	5.9	7.9	1791	0.7	2.4	11.5	5350	83
615	AMD 560L2T	2988	94.8	94.3	0.88	0.86	38	6.4	10.5	1966	0.8	2.6	11.2	5350	83
690	AMD 560L2T	2985	95.0	94.7	0.91	0.90	41	6.1	8.6	2207	0.8	2.4	12.3	5600	83
775	AMD 560L2T	2986	95.4	95.0	0.90	0.89	47	6.3	10.6	2478	0.8	2.5	13.0	5840	83
875	AMD 560L2T	2984	95.4	95.3	0.91	0.90	52	5.8	10.6	2800	0.7	2.3	13.2	5840	83
975	AMD 630L2T	2987	94.6	94.1	0.91	0.90	59	6.3	12.5	3117	0.8	2.5	21.3	7270	85
1250	AMD 630L2T	2987	95.1	94.8	0.91	0.89	75	6.5	16.8	3996	0.8	2.6	22.7	7570	85
1400	AMD 710M2T	2989	94.5	93.8	0.93	0.92	83	6.1	14.0	4473	0.5	2.6	51.0	11000	87
1600	AMD 710M2T	2989	94.8	94.2	0.92	0.92	95	6.3	16.3	5112	0.5	2.6	53.8	11370	87
1800	AMD 710X2T	2989	95.1	94.5	0.93	0.93	106	6.2	16.6	5751	0.5	2.6	62.8	13000	87
2000	AMD 710X2T	2989	95.4	94.8	0.93	0.92	118	6.3	19.0	6390	0.5	2.6	62.8	13000	87
2250	AMD 710X2T	2988	95.6	95.2	0.93	0.93	132	6.2	20.3	7190	0.5	2.6	65.9	13390	87
2500	AMD 710X2T	2989	95.8	95.5	0.92	0.92	147	6.3	24.3	7988	0.5	2.7	65.9	13390	87
3000	AMD 900L2T	2987	95.9	95.5	0.92	0.92	176	5.6	26.2	9592	0.5	2.4	93.8	18630	88
3550	AMD 900L2T	2987	96.2	95.9	0.93	0.93	207	5.5	29.1	11350	0.4	2.4	99.6	19120	88
1500 r/min = 4 poles		11000 V 50 Hz													
400	AMD 500L4T	1488	94.0	93.8	0.89	0.88	25	5.5	6.9	2567	0.7	2.2	11.0	4480	81
450	AMD 500L4T	1488	94.2	94.1	0.89	0.86	28	5.7	8.5	2888	0.8	2.3	11.0	4480	81
500	AMD 500L4T	1488	94.4	94.4	0.89	0.87	31	5.7	9.0	3209	0.8	2.3	12.0	4700	81
560	AMD 500L4T	1488	94.7	94.7	0.89	0.87	35	5.8	9.8	3594	0.8	2.3	13.0	4920	81
630	AMD 500L4T	1487	94.9	94.9	0.89	0.87	39	5.9	11.6	4045	0.9	2.3	13.6	5120	81
660	AMD 560L4T	1490	94.6	94.3	0.90	0.88	41	6.5	11.2	4229	0.9	2.5	26.9	5600	82
800	AMD 560L4T	1490	94.9	94.7	0.90	0.88	49	6.6	13.7	5126	1.0	2.5	28.8	5840	82
1120	AMD 630L4T	1491	95.2	95.0	0.91	0.90	68	6.2	16.2	7175	0.9	2.3	41.9	7570	83
1400	AMD 630L4T	1490	95.5	95.4	0.91	0.90	84	6.3	19.2	8970	0.9	2.3	47.3	8150	83
1700	AMD 710M4T	1489	95.4	95.3	0.92	0.92	101	5.5	17.1	10904	0.8	2.1	73.8	10930	82
1900	AMD 710M4T	1490	95.9	95.7	0.91	0.90	115	5.8	25.7	12173	0.9	2.2	78.2	11300	82
2100	AMD 710M4T	1491	96.0	95.9	0.91	0.90	127	6.0	29.1	13447	0.8	2.3	78.5	11300	82
2250	AMD 710L4T	1490	95.9	95.9	0.92	0.92	134	5.3	23.3	14424	0.8	2.0	94.2	12000	82
2500	AMD 710L4T	1490	96.2	96.2	0.92	0.92	148	5.3	25.7	16027	0.8	2.0	99.0	12330	82
2800	AMD 710L4T	1490	96.3	96.4	0.92	0.92	166	5.5	29.1	17940	0.7	2.0	104.9	12660	82
3000	AMD 710X4T	1491	96.4	96.3	0.93	0.93	175	6.1	31.5	19208	0.7	2.5	139.2	14120	82
3250	AMD 710X4T	1490	96.3	96.3	0.93	0.94	190	5.4	28.5	20829	0.6	2.2	145.4	14470	82
3600	AMD 710X4T	1490	96.7	96.8	0.93	0.93	210	5.8	34.7	23067	0.7	2.3	151.6	14810	82
4250	AMD 900L4T	1494	97.0	96.9	0.92	0.92	249	5.5	42.5	27166	0.5	2.1	328.9	21390	84
5150	AMD 900L4T	1494	97.2	97.2	0.92	0.92	302	5.8	53.8	32918	0.6	2.2	340.9	21820	84
6120	AMD 900L4T	1493	97.3	97.3	0.92	0.92	359	5.4	60.7	39136	0.6	2.0	353.0	22240	84

HV Flameproof motors, AMD T IIB

Technical data for totally enclosed squirrel cage three phase motors

11000 V, 50 Hz

IP55 – IC511 – insulation class F, temperature rise class B

Output (kW)	Motor type	Speed (r/min)	Efficiency		Power factor		Current			Torque			Rotor inertia (kgm ²)	Motor weight (kg)	Sound pressure level L _p (dB(A))
			Full load 100%	3/4 load 75%	Full load 100%	3/4 load 75%	I _N (A)	I _S I _N (pu)	I ₀ (A)	T _N (Nm)	T _S T _N (pu)	T _{max} T _N (pu)			
1000 r/min = 6 poles			11000 V 50 Hz												
630	AMD 560L6T	991	94.9	95.1	0.83	0.81	42	4.6	14.4	6071	0.7	1.7	28.8	5840	81
710	AMD 560L6T	990	95.1	95.4	0.83	0.82	47	4.4	15.0	6847	0.7	1.7	30.8	6060	81
800	AMD 630L6T	992	94.9	95.0	0.89	0.87	50	5.8	13.9	7700	1.0	2.2	65.2	7870	80
900	AMD 630L6T	992	95.1	95.2	0.89	0.88	56	5.8	15.0	8665	1.0	2.1	69.5	8150	80
1000	AMD 710M6T	993	95.5	95.4	0.90	0.89	61	6.0	14.4	9612	0.9	2.2	106.8	10160	79
1120	AMD 710M6T	993	95.7	95.6	0.90	0.89	68	5.9	16.4	10767	0.9	2.2	106.8	10160	79
1250	AMD 710M6T	993	95.6	95.7	0.90	0.89	76	5.7	17.6	12025	0.8	2.1	106.8	10160	79
1400	AMD 710M6T	993	95.8	95.9	0.90	0.89	85	5.8	19.6	13467	0.9	2.2	114.3	10550	79
1600	AMD 710L6T	993	96.3	96.4	0.91	0.90	96	5.7	20.2	15386	0.9	2.1	135.2	12660	79
1800	AMD 710L6T	993	96.4	96.4	0.90	0.89	109	6.0	25.6	17301	0.9	2.2	141.1	12980	79
2000	AMD 710X6T	993	96.4	96.6	0.91	0.91	119	5.6	23.1	19229	0.8	2.1	183.5	14470	79
2250	AMD 710X6T	993	96.5	96.7	0.91	0.91	134	5.5	25.7	21640	0.8	2.0	191.5	14810	79
2500	AMD 900L6T	996	97.0	97.0	0.90	0.89	150	5.7	36.0	23958	0.6	2.1	390.2	21390	95
3150	AMD 900L6T	996	97.1	97.1	0.90	0.90	188	5.8	41.4	30201	0.7	2.1	407.4	21820	95
3550	AMD 900L6T	996	97.2	97.3	0.90	0.89	213	5.8	48.7	34032	0.7	2.1	419.4	22240	95
4000	AMD 900L6T	996	97.2	97.3	0.89	0.88	241	5.9	59.4	38342	0.7	2.1	430.2	22650	95
750 r/min = 8 poles			11000 V 50 Hz												
650	AMD 630L8T	745	95.0	95.0	0.83	0.79	43	5.9	17.0	8330	1.0	2.2	58.5	7870	82
770	AMD 630L8T	745	95.1	95.2	0.85	0.82	50	6.0	17.9	9876	1.1	2.1	62.4	8150	82
900	AMD 630L8T	745	95.4	95.4	0.84	0.81	59	6.1	22.1	11540	1.1	2.2	69.8	8690	82
900	AMD 710M8T	743	95.5	95.6	0.87	0.86	57	5.5	16.2	11567	1.0	2.0	111.0	10550	74
1000	AMD 710M8T	744	95.7	95.8	0.88	0.86	63	5.5	17.6	12841	0.9	2.0	119.2	10930	74
1120	AMD 710M8T	744	95.8	96.0	0.88	0.86	70	5.5	19.5	14383	0.9	2.0	126.7	11300	74
1250	AMD 710M8T	743	95.9	96.1	0.88	0.87	78	5.4	20.3	16058	0.9	2.0	142.0	12000	74
1400	AMD 710L8T	745	96.2	96.2	0.86	0.84	88	6.1	28.9	17952	0.9	2.2	136.3	12660	74
1600	AMD 710L8T	743	96.1	96.3	0.88	0.87	99	5.4	24.7	20561	0.9	2.0	150.7	13290	74
1800	AMD 710X8T	745	96.2	96.2	0.89	0.88	111	5.7	28.3	23062	0.7	2.2	212.0	15470	74
2000	AMD 900L8T	747	96.9	96.8	0.89	0.87	122	5.5	34.5	25570	0.6	2.2	333.0	21390	89
2500	AMD 900L8T	746	97.0	97.0	0.90	0.88	151	5.6	38.9	31981	0.6	2.2	361.4	22240	89
3000	AMD 900L8T	746	96.9	97.0	0.89	0.88	182	5.7	48.3	38387	0.7	2.1	373.9	22650	89

HV Flameproof motors, AMD T IIB

Technical data for totally enclosed squirrel cage three phase motors

11000 V, 50 Hz

IP55 – IC511 – insulation class F, temperature rise class B

Output (kW)	Motor type	Speed (r/min)	Efficiency		Power factor		Current			Torque			Rotor inertia (kgm ²)	Motor weight (kg)	Sound pressure level L _p (dB(A))
			Full load 100%	3/4 load 75%	Full load 100%	3/4 load 75%	I _N (A)	I _S I _N (pu)	I ₀ (A)	T _N (Nm)	T _S T _N (pu)	T _{max} T _N (pu)			
600 r/min = 10 poles			11000 V 50 Hz												
400	AMD 630M10T	597	94.5	94.4	0.80	0.74	28	5.9	13.1	6403	0.9	2.4	78.1	7870	82
500	AMD 710M10T	596	94.7	94.8	0.85	0.82	33	5.5	11.7	8011	0.9	2.1	113.7	10550	74
560	AMD 710M10T	596	94.9	95.0	0.86	0.83	36	5.6	12.5	8974	0.9	2.1	121.6	10930	74
630	AMD 710M10T	596	95.0	95.2	0.85	0.82	41	5.6	14.7	10094	0.9	2.1	121.2	10930	74
710	AMD 710M10T	596	95.2	95.4	0.85	0.82	46	5.6	16.2	11378	0.9	2.1	128.8	11300	74
800	AMD 710M10T	596	95.4	95.5	0.85	0.82	52	5.7	18.3	12820	0.9	2.1	136.4	11650	74
900	AMD 710L10T	596	95.5	95.7	0.86	0.83	58	5.8	19.8	14424	1.0	2.1	151.5	12330	74
1000	AMD 710L10T	596	95.8	96.0	0.85	0.82	64	5.8	22.2	16023	1.0	2.1	166.6	12980	74
1120	AMD 710L10T	596	95.9	96.1	0.85	0.82	72	5.9	25.9	17941	1.0	2.1	181.3	13590	74
1250	AMD 710X10T	596	95.8	96.0	0.87	0.85	79	5.5	23.6	20044	0.9	2.0	230.2	14810	74
1500	AMD 710X10T	596	96.2	96.3	0.87	0.85	94	5.8	27.9	24018	0.9	2.0	265.1	15790	74
1800	AMD 900M10T	597	96.7	96.7	0.87	0.86	113	5.2	30.4	28787	0.6	1.8	533.7	21390	84
2300	AMD 900L10T	597	96.8	96.9	0.87	0.86	144	5.3	39.0	36789	0.7	1.8	573.6	22240	84
2700	AMD 900L10T	597	96.9	96.9	0.85	0.83	171	5.8	55.1	43160	0.8	2.0	610.2	23050	84
500 r/min = 12 poles			11000 V 50 Hz												
500	AMD 710M12T	497	95.1	95.0	0.80	0.74	35	5.4	16.1	9615	0.8	2.3	113.9	10550	74
560	AMD 710M12T	496	95.2	95.2	0.80	0.75	39	5.4	17.8	10771	0.8	2.3	121.4	10930	74
630	AMD 710M12T	496	95.3	95.3	0.80	0.74	43	5.4	20.1	12117	0.8	2.3	129.0	11300	74
710	AMD 710M12T	496	95.2	95.4	0.83	0.79	47	5.0	18.2	13678	0.8	2.0	137.5	11650	74
800	AMD 710L12T	497	95.3	95.3	0.80	0.74	55	5.7	25.9	15382	1.0	2.4	152.4	12330	74
1120	AMD 710X12T	496	95.7	95.9	0.84	0.80	73	5.5	28.0	21543	0.8	2.2	213.2	15140	74
1250	AMD 710X12T	496	95.7	95.9	0.84	0.80	82	5.5	31.3	24049	0.9	2.2	222.0	15470	74
1400	AMD 900M12T	497	96.0	96.1	0.83	0.79	93	5.1	35.0	26885	0.6	2.0	506.0	20960	80
1700	AMD 900L12T	497	96.2	96.2	0.82	0.77	114	5.6	46.5	32636	0.7	2.1	545.5	21820	80
2000	AMD 900L12T	497	96.3	96.3	0.82	0.78	133	5.5	52.9	38409	0.7	2.0	585.1	22650	80

HV Flameproof motors, AMD T IIB

Technical data for totally enclosed squirrel cage three phase motors

11000 V, 50 Hz

IP55 – IC511 – insulation class F, temperature rise class B

Output (kW)	Motor type	Speed (r/min)	Efficiency		Power factor		Current			Torque			Rotor inertia (kgm ²)	Motor weight (kg)	Sound pressure level L _p (dB(A))
			Full load 100%	3/4 load 75%	Full load 100%	3/4 load 75%	I _N (A)	I _S I _N (pu)	I ₀ (A)	T _N (Nm)	T _S T _N (pu)	T _{max} T _N (pu)			
425 r/min = 14 poles		11000 V 50 Hz													
500	AMD 710M14T	425	94.6	94.6	0.75	0.69	37	4.4	18.3	11246	0.8	1.9	120.2	11300	74
560	AMD 710M14T	424	94.6	94.7	0.76	0.71	41	4.3	19.4	12604	0.8	1.8	127.3	11650	74
630	AMD 710L14T	424	94.9	95.0	0.76	0.71	46	4.3	21.3	14176	0.8	1.9	148.5	12660	74
710	AMD 710L14T	425	95.1	95.1	0.74	0.68	53	4.7	27.1	15960	0.9	2.0	162.7	13290	74
800	AMD 710L14T	425	95.2	95.2	0.75	0.69	59	4.6	29.5	17990	0.9	2.0	176.8	13890	74
900	AMD 710X14T	424	94.8	95.1	0.84	0.81	59	4.9	21.8	20292	0.9	2.1	232.7	15470	74
1060	AMD 900M14T	426	95.4	95.6	0.82	0.79	71	4.7	27.3	23773	0.6	2.0	526.3	21390	76
1200	AMD 900L14T	426	95.7	95.7	0.81	0.76	81	5.2	34.9	26892	0.7	2.2	566.0	22240	76
1320	AMD 900L14T	426	95.8	95.8	0.80	0.75	90	5.5	40.8	29574	0.8	2.3	585.9	22650	76
375 r/min = 16 poles		11000 V 50 Hz													
400	AMD 710L16T	371	94.2	94.2	0.74	0.68	30	4.2	15.1	10283	0.7	1.9	157.1	12660	74
450	AMD 710L16T	372	94.4	94.2	0.72	0.65	35	4.5	19.4	11557	0.8	2.1	164.7	12980	74
500	AMD 710L16T	372	94.5	94.3	0.71	0.65	39	4.5	21.8	12843	0.9	2.1	172.3	13290	74
560	AMD 710X16T	372	94.3	94.1	0.73	0.67	42	5.0	22.9	14374	0.9	2.2	215.6	14810	74
600	AMD 710X16T	372	94.3	94.3	0.76	0.70	44	4.5	21.7	15419	0.8	2.0	224.9	15140	74
700	AMD 710X16T	371	94.3	94.4	0.76	0.70	51	4.5	24.9	17996	0.8	1.9	234.2	15470	74
800	AMD 900M16T	373	95.2	95.2	0.75	0.69	59	4.7	30.3	20492	0.6	2.1	508.8	20960	74
900	AMD 900L16T	373	95.4	95.3	0.73	0.66	68	5.0	37.1	23043	0.7	2.3	548.8	21820	74
1180	AMD 900L16T	373	95.6	95.5	0.73	0.66	89	4.7	48.1	30222	0.7	2.1	588.7	22650	74
335 r/min = 18 poles		11000 V 50 Hz													
600	AMD 900M18T	332	94.4	93.8	0.62	0.54	54	5.0	36.8	17274	0.9	2.5	503.4	20960	71
700	AMD 900L18T	332	94.6	94.1	0.63	0.55	61	4.9	41.4	20157	0.8	2.5	562.8	22240	71
800	AMD 900L18T	332	94.9	94.4	0.64	0.56	69	5.0	45.5	23043	0.9	2.4	585.8	22650	71

HV Flameproof motors, AMD T IIB

Technical data for totally enclosed squirrel cage three phase motors

6600 V, 60 Hz

IP55 – IC511 – insulation class F, temperature rise class B

Output (kW)	Motor type	Speed (r/min)	Efficiency		Power factor		Current			Torque			Rotor inertia (kgm ²)	Motor weight (kg)	Sound pressure level L _p (dB(A))
			Full load 100%	3/4 load 75%	Full load 100%	3/4 load 75%	I _N (A)	I _S I _N (pu)	I ₀ (A)	T _N (Nm)	T _S T _N (pu)	T _{max} T _N (pu)			
3600 r/min = 2 poles			6600 V 60 Hz												
1230	AMD 560L2T	3579	95.8	95.6	0.92	0.91	121	6.0	22.0	3282	0.7	2.4	13.2	5840	86
1370	AMD 560L2T	3582	96.1	95.8	0.91	0.90	136	6.4	27.9	3653	0.8	2.6	13.9	6060	86
1530	AMD 560L2T	3581	96.1	95.9	0.91	0.90	151	6.4	30.3	4080	0.8	2.6	14.8	6280	86
1590	AMD 630M2T	3586	95.3	94.8	0.91	0.90	159	6.2	33.0	4235	0.7	2.5	23.1	7570	88
1970	AMD 630L2T	3585	95.8	95.4	0.91	0.90	196	6.3	38.9	5247	0.8	2.5	25.1	8150	88
2150	AMD 630L2T	3586	96.0	95.7	0.92	0.91	211	6.4	36.7	5726	0.8	2.5	30.7	9200	88
2200	AMD 630L2T	3586	96.0	95.7	0.91	0.90	219	6.5	45.2	5858	0.8	2.6	27.8	8690	88
1800 r/min = 4 poles			6600 V 60 Hz												
1100	AMD 560L4T	1790	95.4	95.1	0.88	0.86	114	6.5	34.4	5867	0.9	2.4	23.3	5600	85
1230	AMD 560L4T	1787	95.3	95.3	0.90	0.89	126	5.4	26.9	6572	0.9	1.9	25.1	5840	85
1370	AMD 560L4T	1790	95.9	95.7	0.89	0.88	140	6.1	36.9	7308	0.8	2.3	26.8	6060	85
1750	AMD 630L4T	1791	95.9	95.6	0.90	0.89	176	6.4	44.5	9332	0.9	2.4	40.1	7870	86
1970	AMD 630L4T	1791	96.1	95.8	0.91	0.90	197	6.5	47.6	10505	0.9	2.5	45.0	8420	86
3070	AMD 710M4T	1791	96.6	96.4	0.92	0.91	303	6.2	61.7	16366	0.7	2.4	83.9	11650	85
3500	AMD 710L4T	1792	96.6	96.4	0.92	0.91	343	6.5	73.7	18655	0.7	2.6	94.0	12330	85
1200 r/min = 6 poles			6600 V 60 Hz												
960	AMD 560L6T	1191	96.2	96.3	0.87	0.85	100	5.5	28.7	7695	1.0	1.9	35.2	6490	84
1100	AMD 560L6T	1190	96.1	96.3	0.87	0.86	115	4.8	28.7	8831	0.8	1.7	35.2	6490	84
1230	AMD 630L6T	1193	95.9	95.7	0.88	0.86	128	6.3	38.6	9843	1.0	2.2	50.9	7870	83
1370	AMD 630L6T	1193	96.0	95.8	0.88	0.85	142	6.4	43.6	10964	1.0	2.3	54.1	8150	83
1530	AMD 630L6T	1193	96.1	96.0	0.89	0.87	157	6.4	43.9	12246	1.1	2.3	63.8	8950	83
2460	AMD 710L6T	1193	96.6	96.6	0.90	0.90	246	6.2	54.4	19699	1.0	2.2	138.8	12980	82
900 r/min = 8 poles			6600 V 60 Hz												
690	AMD 560L8T	893	95.7	95.7	0.85	0.81	75	5.8	26.8	7375	1.0	2.2	32.8	5840	84
780	AMD 560L8T	894	95.9	95.8	0.83	0.79	86	6.2	33.5	8328	1.1	2.2	35.9	6060	84
830	AMD 560L8T	893	95.7	95.8	0.85	0.82	89	5.9	30.8	8872	1.1	2.1	39.7	6490	84
880	AMD 630L8T	894	95.7	95.6	0.84	0.80	96	6.2	36.5	9401	1.1	2.3	50.2	7270	85
980	AMD 630L8T	893	95.4	95.3	0.86	0.84	104	5.8	33.5	10479	1.0	2.1	57.7	7870	85
1130	AMD 630L8T	893	95.7	95.6	0.86	0.84	120	6.0	39.2	12081	1.1	2.2	65.1	8420	85
1320	AMD 710M8T	894	96.3	96.2	0.88	0.86	137	5.8	38.2	14101	1.0	2.0	126.8	11300	77
1750	AMD 710M8T	894	96.6	96.5	0.87	0.86	182	5.7	51.4	18686	0.9	2.0	142.6	12000	77
1970	AMD 710L8T	894	96.6	96.7	0.89	0.88	201	6.3	51.3	21041	1.1	2.2	165.4	12980	77
720 r/min = 10 poles			6600 V 60 Hz												
500	AMD 560L10T	712	94.3	94.5	0.78	0.75	59	4.2	23.5	6706	0.8	1.7	36.9	6280	83
550	AMD 560L10T	711	94.2	94.5	0.79	0.75	65	4.3	25.8	7384	0.9	1.7	38.4	6490	83
710	AMD 630M10T	715	95.5	95.4	0.81	0.76	80	5.7	35.1	9479	0.9	2.2	53.9	7570	85
800	AMD 630M10T	715	95.7	95.6	0.81	0.76	91	6.0	40.4	10677	1.0	2.3	61.4	8150	85
880	AMD 630M10T	716	95.9	95.7	0.80	0.75	100	6.2	46.6	11739	1.0	2.4	72.4	8950	85
1230	AMD 710M10T	716	96.3	96.1	0.83	0.80	134	6.0	51.2	16398	1.0	2.1	146.2	11300	77
1370	AMD 710L10T	716	96.5	96.5	0.86	0.83	145	5.6	46.2	18271	0.9	2.0	180.8	12660	77

HV Flameproof motors, AMD T IIB

Technical data for totally enclosed squirrel cage three phase motors

6600 V, 60 Hz

IP55 – IC511 – insulation class F, temperature rise class B

Output (kW)	Motor type	Speed (r/min)	Efficiency		Power factor		Current			Torque			Rotor inertia (kgm ²)	Motor weight (kg)	Sound pressure level L _p (dB(A))
			Full load 100%	3/4 load 75%	Full load 100%	3/4 load 75%	I _N (A)	I _S I _N (pu)	I ₀ (A)	T _N (Nm)	T _S T _N (pu)	T _{max} T _N (pu)			
600 r/min = 12 poles			6600 V 60 Hz												
310	AMD 560L12T	595	93.4	93.1	0.74	0.69	39	4.4	19.7	4978	0.8	1.9	30.4	5600	83
340	AMD 560L12T	595	93.7	93.2	0.73	0.68	43	4.6	22.3	5456	0.9	2.0	34.9	6060	83
390	AMD 560L12T	594	93.7	93.6	0.76	0.71	48	4.5	22.6	6265	0.9	1.9	39.5	6490	83
490	AMD 630M12T	595	94.5	94.2	0.76	0.71	60	4.6	28.9	7868	0.8	2.0	49.5	7270	85
550	AMD 630M12T	595	94.5	94.3	0.76	0.70	67	4.6	32.9	8831	0.8	2.0	53.1	7570	85
610	AMD 630M12T	595	94.7	94.5	0.76	0.71	74	4.8	36.0	9793	0.8	2.0	60.5	8150	85
670	AMD 630M12T	594	94.6	94.5	0.78	0.74	79	4.5	34.9	10765	0.8	1.9	67.8	8690	85
1100	AMD 710L12T	596	96.0	96.0	0.82	0.78	122	5.5	51.1	17628	0.8	2.2	170.3	12330	77
510 r/min = 14 poles			6600 V 60 Hz												
220	AMD 560L14T	507	91.8	91.5	0.71	0.65	30	3.9	16.2	4141	0.8	1.9	29.0	5600	83
270	AMD 560L14T	507	92.1	92.0	0.72	0.67	35	3.7	18.1	5090	0.7	1.7	33.3	6060	83
330	AMD 560L14T	506	92.6	92.6	0.74	0.69	42	3.9	20.7	6224	0.8	1.8	39.8	6700	83
420	AMD 630M14T	508	93.5	93.5	0.74	0.69	53	3.7	25.3	7894	0.7	1.7	54.3	7870	85
460	AMD 630M14T	509	94.0	93.9	0.75	0.70	57	3.8	26.9	8636	0.6	1.7	62.4	8420	85
510	AMD 630M14T	509	94.0	93.8	0.73	0.68	65	3.9	32.3	9566	0.6	1.8	69.8	8950	85
690	AMD 710M14T	510	95.1	95.1	0.78	0.73	81	4.6	37.4	12927	0.7	2.1	133.5	11650	77
880	AMD 710L14T	510	95.2	95.3	0.79	0.75	102	4.6	45.0	16492	0.8	2.0	163.8	12980	77
990	AMD 710L14T	509	95.6	95.6	0.80	0.76	113	4.7	48.1	18556	0.8	2.1	194.0	14180	77
450 r/min = 16 poles			6600 V 60 Hz												
310	AMD 630M16T	443	92.6	92.5	0.71	0.66	41	3.4	21.2	6687	0.7	1.7	60.0	8420	85
340	AMD 630M16T	444	92.6	92.2	0.69	0.63	47	3.7	26.1	7321	0.7	1.8	63.6	8690	85
390	AMD 630M16T	443	92.8	92.5	0.70	0.64	53	3.6	28.5	8404	0.7	1.8	70.7	9200	85
690	AMD 710L16T	446	95.2	95.1	0.74	0.69	85	4.5	42.6	14764	0.8	2.0	172.8	13290	77
780	AMD 710L16T	447	95.4	95.2	0.72	0.66	99	4.7	53.7	16677	0.9	2.1	195.7	14180	77

HV Flameproof motors, AMD Rg 355 (IEC) Ex db/(db eb) IIB/IIC T3/T4 Dimension drawings

Antifriction bearings, IM 1001 (IM B3), IC411, cast iron frame

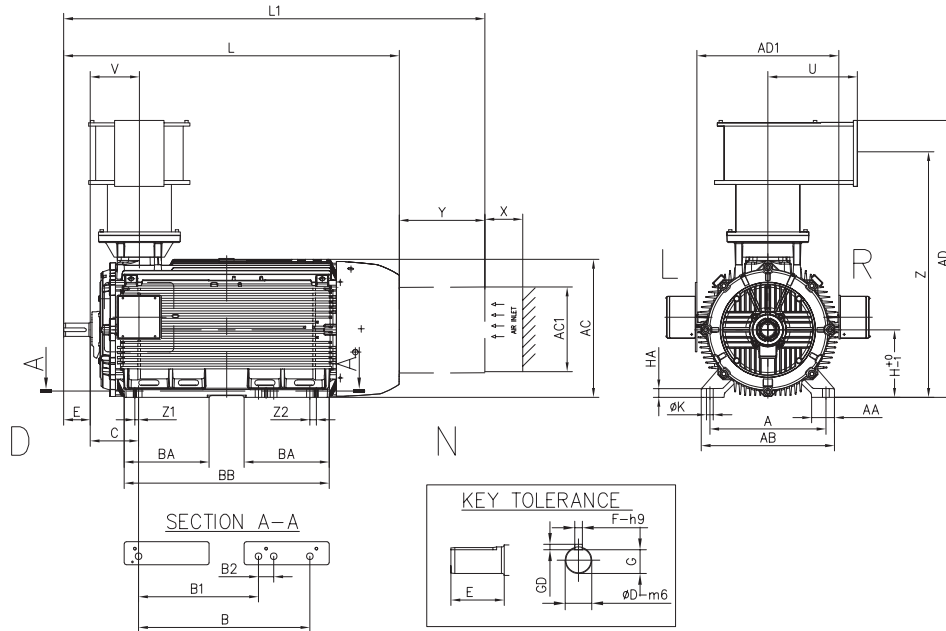

AMDRg	Poles	Frequency (Hz)	GAS Group	A	B	B1	B2	C	D	E	F	G	H	K	L	L1	U	V	X	Y
355 L	2	50-60	IIB	610	900	630	80	254	70	140	20	62.5	355	35	1770	2220	470	258	200	450
355 L	4-6	50-60		610	900	630	80	280	100	210	28	90	355	35	1865	2315	470	285	200	450
355 L	2	50-60	IIC	610	900	630	80	254	70	140	20	62.5	355	35	1770	2220	470	258	200	450
355 L	4-6	50-60		610	900	630	80	280	100	210	28	90	355	35	1865	2315	470	285	200	450

AMDRg	Poles	Frequency (Hz)	GAS Group	Z	Z1	Z2	AA	AB	AC	AC1	AD	AD1	BA	BB	GD	HA	D-END Bearing	N-END Bearing
355 L	2	50-60	IIB	1290	20	35	120	700	725	450	1455	750	437	1080	12	45	6316-C3	6316-C3
355 L	4-6	50-60		1290	20	35	120	700	725	450	1455	750	437	1080	16	45	6322-C3	6316-C3
355 L	2	50-60	IIC	1330	20	35	120	700	725	450	1495	750	437	1080	12	45	6316-C3	6316-C3
355 L	4-6	50-60		1330	20	35	120	700	725	450	1495	750	437	1080	16	45	6322-C3	6316-C3

Table gives main dimensions in mm. Please refer to order documentation for final dimensions.

HV Flameproof motors, AMD Rg 400 (IEC) Ex db/(db eb) IIB/IIC T3/T4

Dimension drawings

Antifriction bearings, IM 1001 (IM B3), IC411, cast iron frame

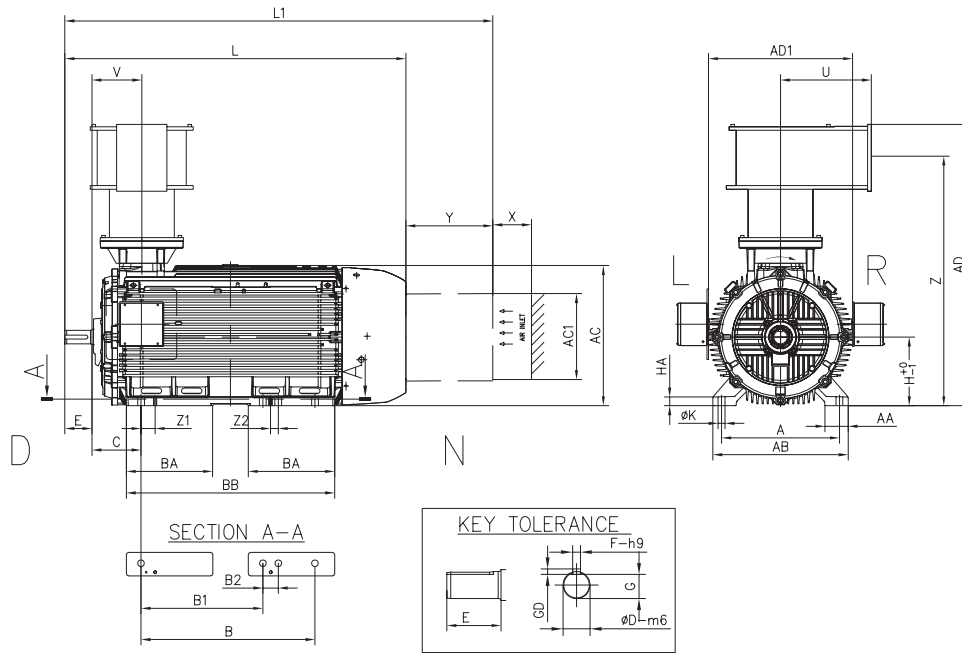

AMDRg	Poles	Frequency (Hz)	GAS Group	A	B	B1	B2	C	D	E	F	G	H	K	L	L1	U	V	X	Y
400 L	2	50-60	IIB	710	1120	900	100	224	80	170	22	71	400	35	2015	2465	470	308	200	450
400 L	4-8	50-60		710	1120	900	100	224	110	210	28	100	400	35	2055	2505	470	309	200	450
400 L	2	50-60	IIC	710	1120	900	100	224	80	170	22	71	400	35	2015	2465	470	308	200	450
400 L	4-8	50-60		710	1120	900	100	224	110	210	28	100	400	35	2055	2505	470	309	200	450

AMDRg	Poles	Frequency (Hz)	GAS Group	Z	Z1	Z2	AA	AB	AC	AC1	AD	AD1	BA	BB	GD	HA	D-END Bearing	N-END Bearing
400 L	2	50-60	IIB	1375	73	50	150	840	815	450	1545	835	410	1316	14	45	6317-C3	6317-C3
400 L	4-8	50-60		1375	73	50	150	840	815	450	1545	835	410	1316	16	45	6324-C3	6319-C3
400 L	2	50-60	IIC	1415	73	50	150	840	815	450	1585	835	410	1316	14	45	6317-C3	6317-C3
400 L	4-8	50-60		1415	73	50	150	840	815	450	1585	835	410	1316	16	45	6324-C3	6319-C3

Table gives main dimensions in mm. Please refer to order documentation for final dimensions.

HV Flameproof motors, AMD Rg 450-500 (IEC) Ex db/(db eb) IIB/IIC T3/T4 Dimension drawings

Antifriction bearings, IM 1001 (IM B3), IC411, cast iron frame

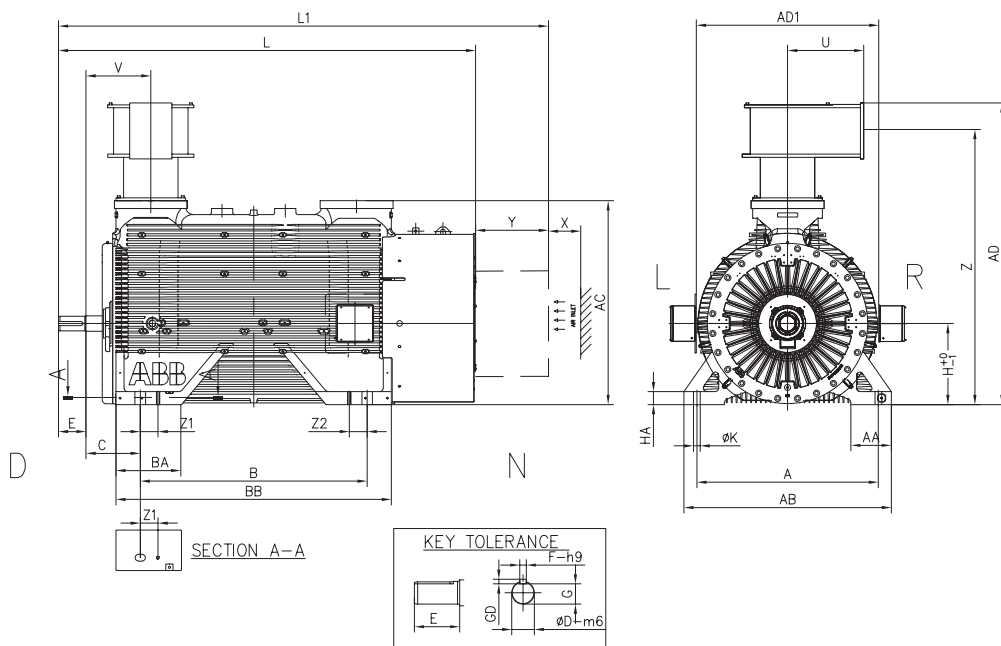

AMDRg	Poles	Frequency (Hz)	GAS Group	A	B	C	D	E	F	G	H	K	L	L1	U	V	X	Y
450 M	2	50-60	IIB	900	1250	375	80	170	22	71	450	42	2425	3090	470	369	250	665
450 M	4-14	50-60		900	1250	375	110	210	28	100	450	42	2465	3130	470	369	250	665
500 S	2	50-60		1120	1400	335	90	170	25	81	500	42	2585	3250	470	397	250	665
500 S	4-18	50-60		1120	1400	335	140	250	36	128	500	42	2655	3320	470	397	250	665
500 M	4-18	50-60		1120	1500	335	140	250	36	128	500	42	2805	3470	470	397	250	665
450 M	2	50-60	IIC	900	1250	375	80	170	22	71	450	42	2425	3090	470	369	250	665
450 M	4-14	50-60		900	1250	375	110	210	28	100	450	42	2465	3130	470	369	250	665
500 S	2	50-60		1120	1400	335	90	170	25	81	500	42	2585	3250	470	397	250	665
500 S	4-18	50-60		1120	1400	335	140	250	36	128	500	42	2655	3320	470	397	250	665
500 M	4-18	50-60		1120	1500	335	140	250	36	128	500	42	2805	3470	470	397	250	665

AMDRg	Poles	Frequency (Hz)	GAS Group	Z	Z1	Z2	AA	AB	AC	AD	AD1	BA	BB	GD	HA	D-END Bearing	N-END Bearing
450 M	2	50-60	IIB	1560	75	75	170	1050	1125	1730	1010	288	1610	14	80	6317-C3	6317-C3
450 M	4-14	50-60		1560	75	75	170	1050	1125	1730	1010	288	1610	16	80	6324-C3	6324-C3
500 S	2	50-60		1695	110	110	250	1280	1258	1865	1130	400	1700	14	80	6319-C3	6319-C3
500 S	4-18	50-60		1695	110	110	250	1280	1258	1865	1130	400	1700	20	80	6330-C3	6330-C3
500 M	4-18	50-60		1695	110	110	250	1280	1258	1865	1130	405	1850	20	80	6330-C3	6330-C3
450 M	2	50-60	IIC	1600	75	75	170	1050	1125	1770	1010	288	1610	14	80	6317-C3	6317-C3
450 M	4-14	50-60		1600	75	75	170	1050	1125	1770	1010	288	1610	16	80	6324-C3	6324-C3
500 S	2	50-60		1735	110	110	250	1280	1258	1905	1130	400	1700	14	80	6319-C3	6319-C3
500 S	4-18	50-60		1735	110	110	250	1280	1258	1905	1130	400	1700	20	80	6330-C3	6330-C3
500 M	4-18	50-60		1735	110	110	250	1280	1258	1905	1130	405	1850	20	80	6330-C3	6330-C3

Table gives main dimensions in mm. Please refer to order documentation for final dimensions.

HV Flameproof motors, AMD Rg 355 (IEC) Ex db/(db eb) IIB T3/T4

Dimension drawings

Sleeve bearings, IM 1001 (IM B3), IC411, cast iron frame

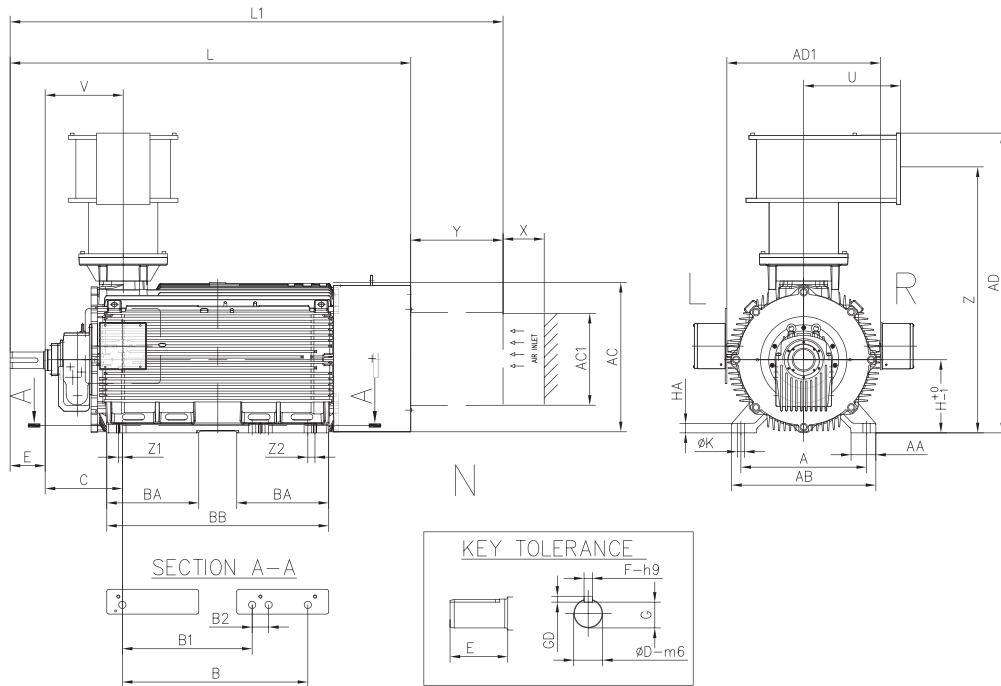

AMDRg	Poles	Frequency (Hz)	GAS Group	A	B	B1	B2	C	D	E	F	G	H	K	L	L1	U	V	X	Y
355 L	2	50	IIB	610	900	630	80	375	80	170	22	71	355	35	1950	2400	470	380	200	450
355 L	4-6	50-60		610	900	630	80	375	90	170	25	81	355	35	1950	2400	470	380	200	450

AMDRg	Poles	Frequency (Hz)	GAS Group	Z	Z1	Z2	AA	AB	AC	AC1	AD	AD1	BA	BB	GD	HA	D-END Bearing	N-END Bearing
355 L	2	50	IIB	1290	20	35	120	700	725	450	1455	750	437	1080	14	45	EFZLB9-80	EFZLQ9-80
355 L	4-6	50-60		1290	20	35	120	700	725	450	1455	750	437	1080	14	45	EFZLB9-80	EFZLQ9-80

Table gives main dimensions in mm. Please refer to order documentation for final dimensions.

HV Flameproof motors, AMD Rg 400 (IEC) Ex db/(db eb) IIB T3/T4

Dimension drawings

Sleeve bearings, IM 1001 (IM B3), IC411, cast iron frame

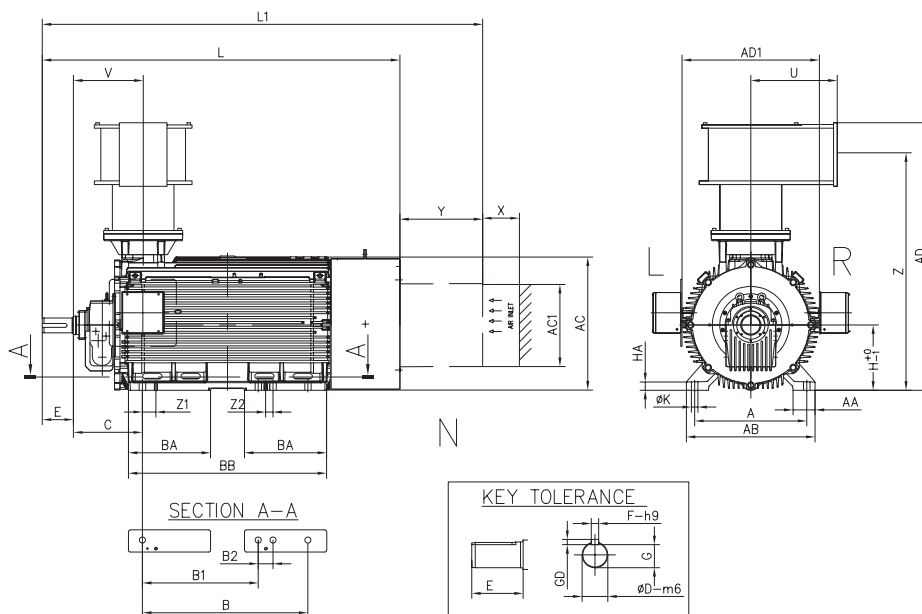

AMDRg	Poles	Frequency (Hz)	GAS Group	A	B	B1	B2	C	D	E	F	G	H	K	L	L1	U	V	X	Y
400 L	2	50	IIB	710	1120	900	100	335	80	170	22	71	400	35	2240	2690	470	308	200	450
400 L	4-8	50-60		710	1120	900	100	375	110	210	28	100	400	35	2370	2820	470	309	200	450

AMDRg	Poles	Frequency (Hz)	GAS Group	Z	Z1	Z2	AA	AB	AC	AC1	AD	AD1	BA	BB	GD	HA	D-END Bearing	N-END Bearing
400 L	2	50	IIB	1375	73	50	150	840	815	450	1545	835	410	1316	14	45	EFZLB9-80	EFZLQ9-80
400 L	4-8	50-60		1375	73	50	150	840	815	450	1545	835	410	1316	16	45	EFZLB11-125	EFZLQ9-100

Table gives main dimensions in mm. Please refer to order documentation for final dimensions.

HV Flameproof motors, AMD Rg 450-500 (IEC) Ex db/(db eb) IIB T3/T4

Dimension drawings

Sleeve bearings, IM 1001 (IM B3), IC411, cast iron frame

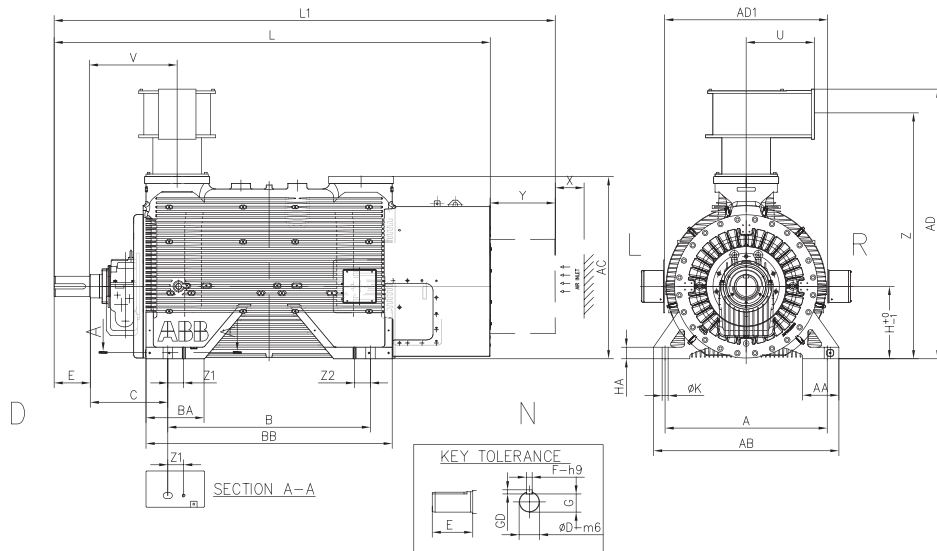

AMDRg	Poles	Frequency (Hz)	A	B	B1	B2	C	D	E	F	G	H	K	L	L1	U	V	X	Y
450 M	2	50-60	900	1250	0	0	600	80	170	22	71	450	42	2810	3475	470	595	250	665
450 M	4-14	50-60	900	1250	0	0	500	100	210	28	90	450	42	2695	3360	470	495	250	665
500 M	2	50-60	1120	1400	0	0	600	100	210	28	90	500	42	3180	3845	470	640	250	665
500 S	4	50-60	1120	1400	0	0	535	140	250	36	128	500	42	3025	3690	470	600	250	665
500 M	4	50-60	1120	1500	0	0	560	140	250	36	128	500	42	3175	3840	470	600	250	665

AMDRg	Poles	Frequency (Hz)	Z	Z1	Z2	AA	AB	AC	AD	AD1	BA	BB	GD	HA	D-END Bearing	N-END Bearing
450 M	2	50-60	1560	75	75	170	1050	1125	1730	1010	288	1610	14	80	EFZLK9-90	EFZLQ9-90
450 M	4-14	50-60	1560	75	75	170	1050	1125	1730	1010	288	1610	16	80	EFZLB9-90	EFZLQ9-90
500 M	2	50-60	1695	110	110	250	1280	1258	1865	1130	400	1700	16	80	EFZLK9-90	EFZLQ9-90
500 S	4	50-60	1695	110	110	250	1280	1258	1865	1130	400	1700	20	80	EFZLB14-125	EFZLQ11-125
500 M	4	50-60	1695	110	110	250	1280	1258	1865	1130	405	1850	20	80	EFZLB14-125	EFZLQ11-125

Table gives main dimensions in mm. Please refer to order documentation for final dimensions.

HV Flameproof motors, AMD Rg 355-400 (IEC) Ex db/(db eb) IIB/IIC T3/T4 Dimension drawings

Antifriction bearings, IM 3011 (IM V1), IC411, cast iron frame

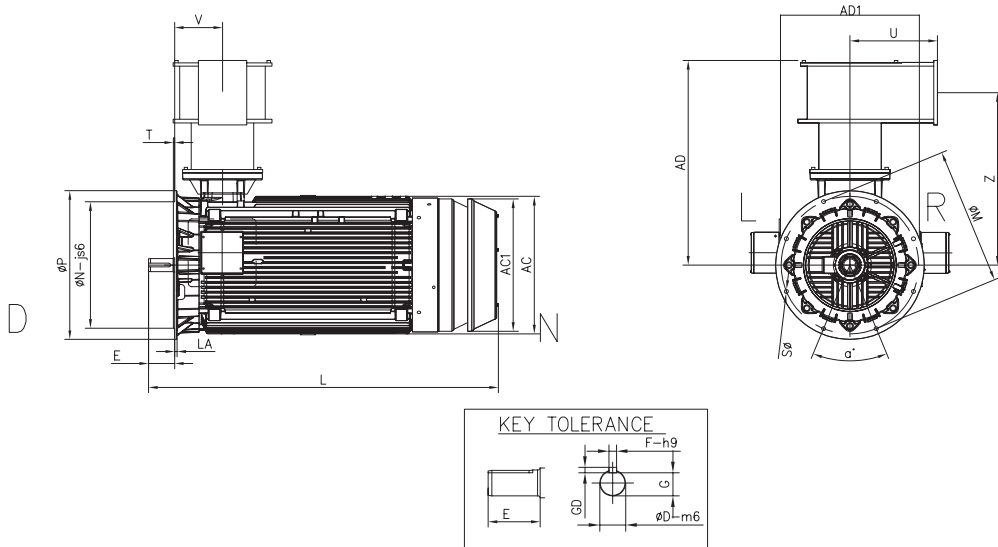

AMDRg	Poles	Frequency (Hz)	GAS Group	D	E	F	G	GD	M	N	L	S	N° holes (S) equidist	a°	V
355 L	2	50-60	IIB	70	140	20	62.5	12	740	680	1885	23	8	45	258
355 L	4-6	50-60		100	210	28	90	16	740	680	1955	23	8	45	258
355 L	2	50-60	IIC	70	140	20	62.5	12	740	680	1885	23	8	45	258
355 L	4-6	50-60		100	210	28	90	16	740	680	1955	23	8	45	258
400 L	2	50-60	IIB	80	170	22	71	14	940	880	2130	28	8	45	310
400 L	4-8	50-60		110	210	28	100	16	940	880	2170	28	8	45	310
400 L	2	50-60	IIC	80	170	22	71	14	940	880	2130	28	8	45	310
400 L	4-8	50-60		110	210	28	100	16	940	880	2170	28	8	45	310

AMDRg	Poles	Frequency (Hz)	GAS Group	AD	Z	AD1	AC	AC1	LA	P	T	U	D-END Bearing	N-END Bearing
355 L	2	50-60	IIB	1100	940	750	740	715	13	800	6	470	6316-C3	7213
355 L	4-6	50-60		1100	940	750	740	715	13	800	6	470	6322-C3	6316-C3
355 L	2	50-60	IIC	1140	980	750	740	715	13	800	6	470	6316-C3	7213
355 L	4-6	50-60		1140	980	750	740	715	13	800	6	470	6322-C3	6316-C3
400 L	2	50-60	IIB	1145	980	835	810	805	13	1000	6	470	6217-C3	7217
400 L	4-8	50-60		1145	980	835	810	805	13	1000	6	470	6324-C3	6319-C3
400 L	2	50-60	IIC	1185	1020	835	810	805	13	1000	6	470	6217-C3	7217
400 L	4-8	50-60		1185	1020	835	810	805	13	1000	6	470	6324-C3	6319-C3

Table gives main dimensions in mm. Please refer to order documentation for final dimensions.

HV Flameproof motors, AMD Rg 450-500 (IEC) Ex db/(db eb) IIB/IIC T3/T4 Dimension drawings

Antifriction bearings, IM 4011 (IM V1), IC411, cast iron frame

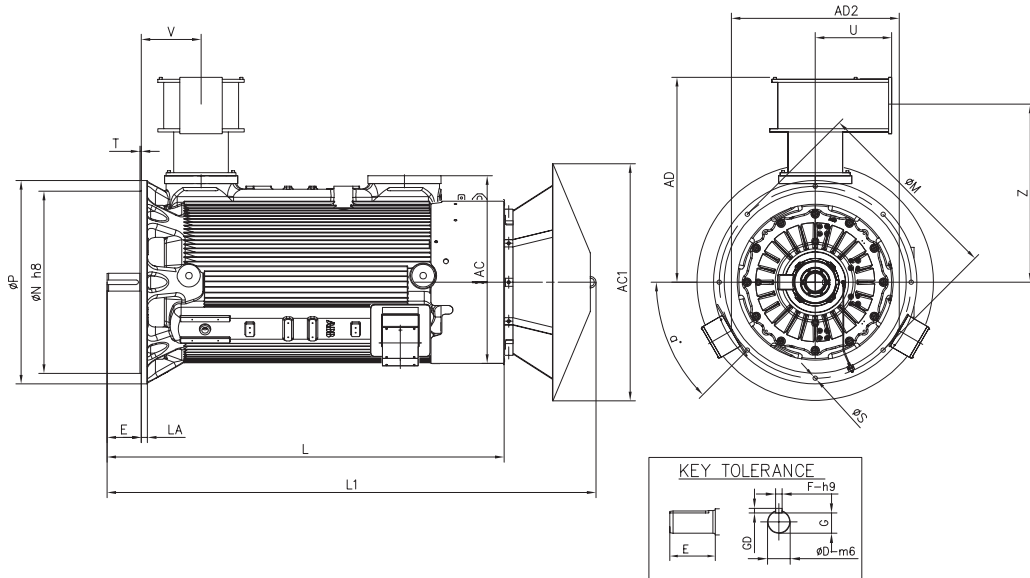

AMDRg	Poles	Frequency (Hz)	GAS Group	D	E	F	G	GD	M	N	L	L1	S	N° holes (S) equidist	a°	V
450 M	2	50-60	IIB	80	170	22	71	14	1180	1120	2230	2795	28	8	45	368
450 M	4-14	50-60		110	210	28	100	16	1180	1120	2440	3010	28	8	45	368
500 M	4-18	50-60		140	250	36	128	20	1320	1250	2790	3360	28	8	45	395
450 M	2	50-60	IIC	80	170	22	71	14	1180	1120	2230	2795	28	8	45	368
450 M	4-14	50-60		110	210	28	100	16	1180	1120	2440	3010	28	8	45	368
500 M	4-18	50-60		140	250	36	128	20	1320	1250	2790	3360	28	8	45	395

AMDRg	Poles	Frequency (Hz)	GAS Group	AD	Z	AD1	AC	AC1	LA	P	T	U	D-END Bearing	N-END Bearing
450 M	2	50-60	IIB	1260	1095	1035	1155	1460	38	1250	7	470	6317-C3	7317
450 M	4-14	50-60		1260	1095	1035	1155	1460	38	1250	7	470	6324-C3	7324
500 M	4-18	50-60		1315	1150	1135	1260	1650	42	1400	8	470	6330-C3	7330
450 M	2	50-60	IIC	1300	1135	1035	1155	1460	38	1250	7	470	6317-C3	7317
450 M	4-14	50-60		1300	1135	1035	1155	1460	38	1250	7	470	6324-C3	7324
500 M	4-18	50-60		1355	1190	1135	1260	1650	42	1400	8	470	6330-C3	7330

Table gives main dimensions in mm. Please refer to order documentation for final dimensions.

HV Flameproof motors, AMD T 500-900 (IEC) Ex db/(db eb) IIB T3/T4

Dimension drawings

Antifriction bearings, IM 1001 (IM B3), IC511, welded steel frame

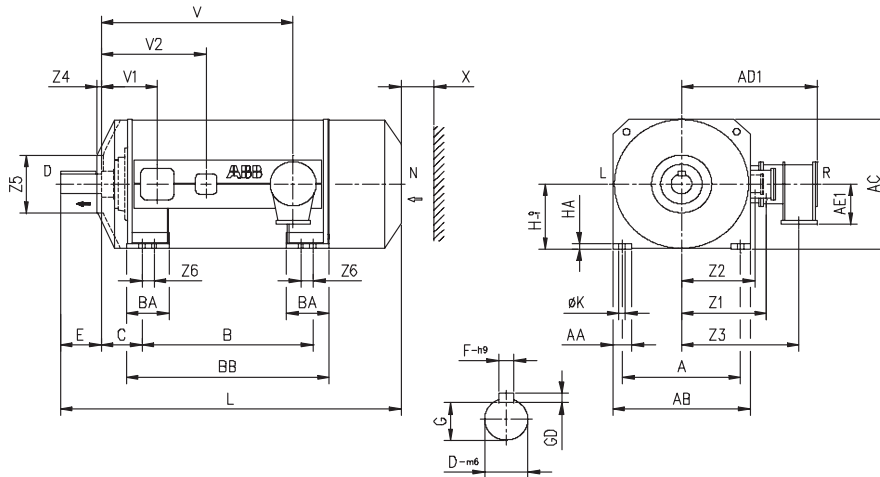

AMD	Poles	Frequency (Hz)	A	B	C	D	E	F	G	H	K	L	V	V1	V2	X	Z1	Z2	Z3	Z4
500 L	2	50	900	1320	224	80	170	22	71	500	42	2590	1370	360	735	200	643	615	1094	60
500 L	4	50-60	900	1320	224	110	210	32	99	500	42	2280	1370	360	735	200	643	615	1094	60
560 L	2	50	1000	1400	224	90	170	25	81	560	42	2675	1455	355	730	250	665	645	1120	60
560 L	4	50-60	1000	1400	250	120	210	32	109	560	42	2390	1480	380	755	250	665	645	1120	35
630 M	2	50	1120	1400	250	90	170	25	81	630	42	2800	1480	380	755	300	730	715	1180	115
630 M	10-14	50-60	1120	1500	250	140	250	36	128	630	42	2615	1580	380	755	300	730	715	1180	56
630 L	4-8	50-60	1120	1600	250	140	250	36	128	630	42	2715	1680	380	755	300	760	740	1210	56
710 M	4-12	50-60	1250	1750	280	160	300	40	147	710	42	2945	1835	435	810	350	850	825	1295	10
710 L	4-12	50-60	1250	2000	280	160	300	40	147	710	42	3195	2085	435	810	350	850	825	1295	10
710 X	4	50-60	1320	2100	280	160	300	40	147	710	42	3300	2185	435	810	350	865	840	1300	10
710 X	6-12	50-60	1320	2000	280	160	300	40	147	710	42	3200	2085	435	810	350	865	840	1300	10
900 L	6	50	1600	2240	335	200	350	45	185	900	42	4250	2409	461	836	350	1023	993	1464	170
900 L	6-18	50	1600	2240	355	220	350	50	203	900	42	4000	2404	506	881	350	1023	993	1464	170
900 M	8-18	50	1600	2100	400	220	350	50	203	900	42	3950	2360	540	915	350	1023	993	1464	-

AMD	Poles	Frequency (Hz)	Z5	Z6	AA	AB	AC	AD1	AE1	BA	BB	GD	HA	D-END Bearing	N-END Bearing
500 L	2	50	630	100	200	1100	1075	1295	470	350	1600	14	35	6317-C3	6317-C3
500 L	4	50-60	630	100	200	1100	1075	1295	470	350	1600	18	35	6324-C3	6319-C3
560 L	2	50	710	100	160	1150	1125	1327	470	350	1690	14	45	6319-C3	6319-C3
560 L	4	50-60	710	100	160	1150	1125	1327	470	350	1690	18	45	6326-C3	6322-C3
630 M	2	50	800	100	180	1280	1265	1392	470	350	1690	14	45	6319-C3	6319-C3
630 M	10-14	50-60	800	100	180	1280	1265	1392	470	350	1790	20	45	6330-C3	6324-C3
630 L	4-8	50-60	800	100	200	1320	1290	1425	470	350	1890	20	45	6330-C3	6324-C3
710 M	4-12	50-60	900	100	240	1490	1455	1477	470	350	1990	22	45	6034-C3 + NU1034-EC	NU322-EC3
710 L	4-12	50-60	900	100	240	1490	1455	1477	470	350	2240	22	45	6034-C3 + NU1034-EC	NU322-EC3
710 X	4	50-60	900	100	260	1560	1490	1507	470	350	2340	22	45	6034-C3 + NU1034-EC	NU322-EC3
710 X	6-12	50-60	900	100	260	1560	1490	1507	470	350	2240	22	45	6034-C3 + NU1034-EC	NU322-EC3
900 L	6	50	1150	124	325	1840	1850	1680	470	450	2540	25	45	6044 M1-C3 + NU1044 M1-C3	NU1044 M1-C3
900 L	6-18	50	1150	124	325	1840	1850	1680	470	450	2490	28	45	6048-C3 + NU1048-C3	NU1048-C3
900 M	8-18	50	-	124	325	1840	1850	1680	470	450	2412	28	45	6048-C3 + NU1048-C3	NU1048-C3

Table gives main dimensions in mm. Please refer to order documentation for final dimensions.

HV Flameproof motors, AMD T 500-900 (IEC) Ex db/(db eb) IIB T3/T4

Dimension drawings

Sleeve bearings, IM 1001 (IM B3), IC511, welded steel frame

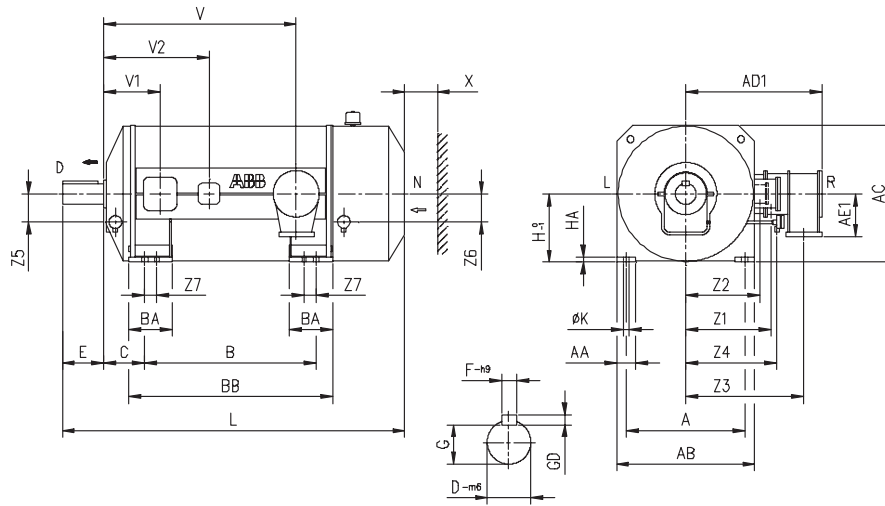

AMD	Poles	Frequency (Hz)	A	B	C	D	E	F	G	H	K	L	V	V1	V2	X	Z1	Z2	Z3	Z4
500 L	2	50-60	900	1320	475	80	170	22	71	500	42	3110	1619	611	986	250	643	615	1094	700
500 L	4	50-60	900	1320	500	110	210	32	99	500	42	2755	1644	636	1026	250	643	615	1094	700
560 M	2	50-60	1000	1250	375	90	170	25	81	560	42	2880	1454	506	881	250	665	640	1120	850
560 L	2	50-60	1000	1400	375	90	170	25	81	560	42	3040	1604	506	881	250	665	640	1120	850
560 L	4	50-60	1000	1400	400	120	210	32	109	560	42	2670	1630	531	906	250	665	640	1120	850
630 M	2	50-60	1120	1400	375	90	170	25	81	630	42	2960	1604	506	881	300	740	715	1180	900
630 M	10-12	50-60	1120	1500	450	140	250	36	128	630	42	2975	1780	581	956	300	740	715	1180	900
630 L	2	50-60	1120	1700	375	100	210	28	90	630	42	3300	1905	506	881	300	755	740	1210	920
630 L	4/8	50-60	1120	1600	450	140	250	36	128	630	42	3075	1880	581	956	300	755	740	1210	920
710 S	2	50-60	1250	1500	375	120	210	32	109	710	42	3310	1590	531	906	350	830	805	1295	1010
710 M	2	50-60	1250	1600	400	120	210	32	109	710	42	3320	1805	556	931	350	810	790	1260	1000
710 M	4-6	50-60	1250	1750	450	160	300	40	147	710	42	3245	2005	606	981	350	830	805	1295	1010
710 M	8-12	50-60	1250	1750	450	160	300	40	147	710	42	3315	2005	606	981	350	830	805	1295	1010
710 L	4-6	50-60	1250	2000	450	160	300	40	147	710	42	3565	2255	606	981	350	830	805	1295	1010
710 L	8-12	50-60	1250	2000	450	160	300	40	147	710	42	3565	2255	606	981	350	830	805	1295	1010
710 X	2	50-60	1250	1800	375	120	210	32	109	710	42	3600	1980	531	895	350	865	840	1320	1030
710 X	4	50-60	1320	2100	450	175	300	45	160	710	42	3650	2355	606	981	350	820	845	1300	1010
710 X	6-12	50-60	1320	2000	450	175	300	45	160	710	42	3800	2255	606	981	350	820	845	1300	1010
900 L	2	50	1600	2000	500	140	300	36	128	900	42	4050	2305	660	1030	350	1023	993	1464	1150
900 L	4	50	1600	2240	560	200	350	45	185	900	42	4450	2634	686	1061	350	1023	993	1464	1150
900 L	6-18	50	1600	2240	530	220	350	50	203	900	42	4100	2579	681	1056	350	1023	993	1464	1150
900 M	8-18	50	1600	2100	560	220	350	50	203	900	42	4050	2520	700	1075	350	1023	993	1464	1150

Table gives main dimensions in mm. Please refer to order documentation for final dimensions.

HV Flameproof motors, AMD T 500-900 (IEC) Ex db/(db eb) IIB T3/T4

Dimension drawings

Antifriction bearings, IM 4011 (IM V1), IC511, welded steel frame

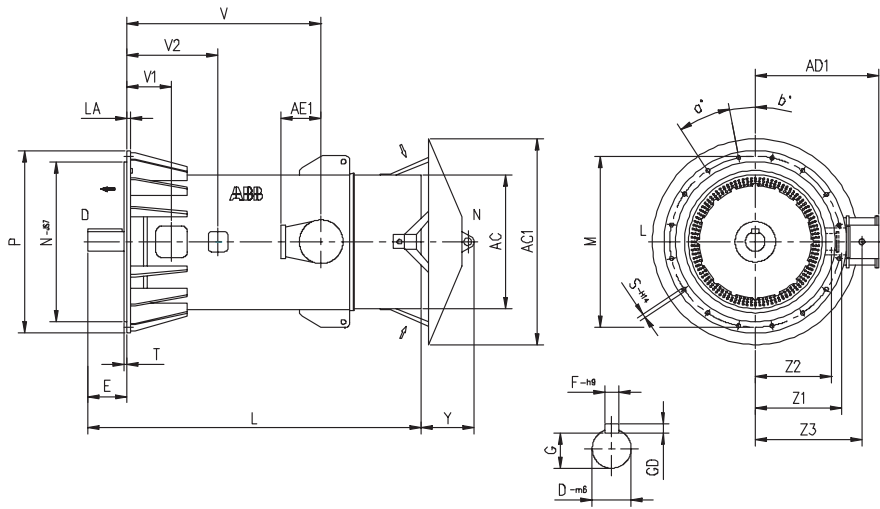

AMD	Poles	Frequency (Hz)	D	E	F	G	L	M	N	P	S	T	V	V1	V2	Y	Z1
500 L	4	50-60	110	210	32	99	2300	1180	1120	1250	28	7	1390	380	770	340	615
560 L	4	50-60	120	210	32	109	2380	1320	1250	1400	28	8	1480	381	746	340	650
630 M	10-14	50-60	140	250	36	128	2645	1600	1500	1700	34	10	1616	418	803	340	747
630 L	4-12	50-60	140	250	36	128	2750	1600	1500	1700	34	10	1716	418	803	340	747
710 M	4-12	50	160	300	40	147	2950	1700	1600	1800	26	10	1834	436	811	400	820
710 L	4-12	50	160	300	40	147	3194	1700	1600	1800	26	10	2155	436	811	400	820
710 X	6-12	50	160	300	40	147	3208	1900	1800	2000	35	10	2104	446	821	340	880
900 L	6-18	50	200	350	45	185	3775	2360	2240	2500	35	10	2354	456	831	290	1060
900 M	6-18	50	200	350	45	185	3695	2360	2240	2500	35	10	2276	456	831	290	1060

AMD	Poles	Frequency (Hz)	Z2	Z3	AC	AC1	AD1	AE1	GD	LA	N° holes	a°	b°	D-END Bearing	N-END Bearing
500 L	4	50-60	615	1050	1010	1310	1252	470	18	30	8	45	22.5	6024-C3	7319
560 L	4	50-60	650	1115	1090	1360	1327	470	18	40	8	45	22.5	6026-C3	7322
630 M	10-14	50-60	747	1210	1276	1545	1415	470	20	57	12	30	0	6030-C3	7324
630 L	4-12	50-60	747	1210	1276	1545	1415	470	20	57	12	30	0	6030-C3	7324
710 M	4-12	50	790	1270	1390	1430	1477	470	22	47	12	30	15	6034-C3	7330
710 L	4-12	50	790	1270	1390	1430	1477	470	22	47	12	30	15	6034-C3	7330
710 X	6-12	50	835	1315	1482	1762	1522	470	22	67	12	30	15	6034-C3	7330
900 L	6-18	50	1015	1495	1830	2145	1688	470	25	67	12	30	15	6044-C3	2x 7334
900 M	6-18	50	1015	1495	1830	2145	1688	470	25	67	12	30	15	6044-C3	2x 7334

Table gives main dimensions in mm. Please refer to order documentation for final dimensions.

Total product offering

ABB offers a wide range of motors, generators and mechanical power transmission products with a complete portfolio of services.



IEC motors

- Low voltage motors
- High voltage induction motors
- Synchronous motors
- Marine motors
- Motors for explosive atmospheres
- Motors for food and beverage
- Motors for variable speed drives
- Permanent magnet motors
- Synchronous reluctance motors
- Traction motors

NEMA motors

- Low voltage motors
- High voltage induction motors
- Synchronous motors
- Marine motors
- Motors for explosive atmospheres
- Motors for variable speed drives
- Permanent magnet motors
- Servomotors
- Washdown motors

Generators

- Generators for wind turbines
- Generators for diesel and gas engine power plants
- Generators for steam and gas turbine power plants
- Generators for marine applications
- Generators for industrial applications
- Generators for traction applications

Synchronous condensers

Mechanical power transmission components, bearings, gearings

- Mounted bearings
- Enclosed gearing
- Couplings
- Conveyor components
- Geared motor units

Life cycle services and support

Life cycle services and support

From pre-purchase to migration and upgrades

ABB offers a complete portfolio of services to ensure trouble-free operation and long product lifetimes. These services cover the entire life cycle. Local support is provided through a global network of ABB service centers and certified partners.

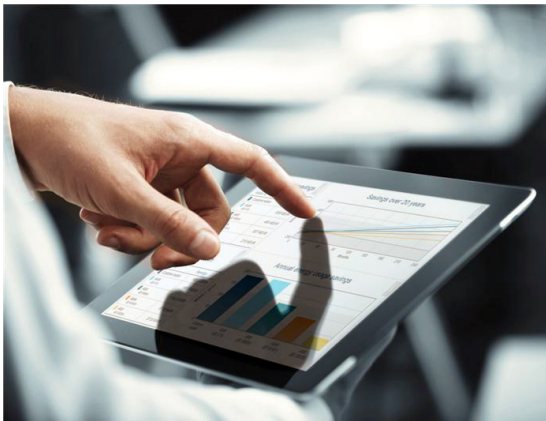

Pre-purchase



ABB's front-end sales organization can help customers to quickly and efficiently select, configure and optimize the right motor for their application.

Installation and commissioning



Professional installation and commissioning by ABB's certified engineers represent an investment in availability and reliability over the entire life cycle.

Engineering and consulting



ABB's experts provide energy efficiency and reliability appraisals, advanced condition and performance assessments and technical studies.

Condition Monitoring and Diagnosis



Unique services provide early warnings before failures occur. Data can be collected by an engineer on-site or by remote monitoring. With the ABB Ability™ platform data can be transmitted to the cloud and accessed and analyzed remotely, allowing even greater insight into the health of the equipment. The services focus on the bearings, rotor winding, stator winding insulation and overall mechanical condition.

Maintenance and field services



ABB offers life cycle management plans and preventive maintenance products. The recommended four-level maintenance program covers the entire product lifetime.

Spare parts



Spare parts and support are offered throughout the life cycle of ABB products. In addition to individual spares, tailored spare part packages are also available.

Repair and refurbishment



Support for all ABB generators and other brands is provided by ABB's global service organization. Specialist teams can also deliver emergency support.

Migration and upgrades



Life cycle audits determine the optimum upgrades and migration paths. Upgrades range from individual components to direct replacement motors.

Training



Product and service training courses take a practical approach. The training ranges from standard courses to specially tailored programs to suit customer requirements.

Specialized support



Specialized support is offered through ABB's global service organization. Local units provide major and minor repairs as well as overhauls and reconditioning.

Service contracts



Service contracts are tailored to the customer's needs. The contracts combine ABB's entire service portfolio and 120 years of experience to deploy the optimal service practices.

Additional information

We reserve the right to make technical changes or modify the contents of this document without prior notice. With regard to purchase orders, the agreed particulars shall prevail. ABB does not accept any responsibility whatsoever for potential errors or possible lack of information in this document.

We reserve all rights in this document and in the subject matter and illustrations contained therein. Any reproduction, disclosure to third parties or utilization of its contents – in whole or in parts – is forbidden without prior written consent of ABB.



—
For more information, please contact
your local ABB representative or visit

new.abb.com/motors-generators