



Keeping Industry Turning

Single Phase Motors

Frame sizes 60 to 100L



Single phase motors

63 - 100L



Brook Crompton

Brook Crompton is a leading manufacturer of electric motors for the global industrial market, with motor solutions which benefit a wide range of customers.

Our products are used in almost every industrial activity including water treatment, building services, chemical/petrochemicals, general processing and manufacturing where they drive fans, pumps, compressors and conveyors, amongst other things.

Brook Crompton incorporates many well known names including Brook Motors, Crompton Parkinson, Electrodrives, Newman, Bull Electric and Hawker Siddeley Electric Motors.

We have extensive stocks of motors around the world, backed-up by a network of distributors, ensuring excellent local support wherever needed.

Quality assurance

Stringent quality procedures are observed from first design to finished product in accordance with the ISO9001 documented quality systems.

All of our factories have been assessed to meet these requirements, a further assurance that only the highest possible standards of quality are accepted.

Single phase motors

Single phase motors are used primarily in small workshops and farms with a domestic supply. Some industrial equipment are specifically designed for use with a single phase electricity supply, such as fans, blowers, centrifugal pumps and high pressure washers

Efficiency

Brook Crompton are an approved manufacturer of ac electric motors within the UK Government's Enhanced Capital Allowance (ECA) scheme. A wide range of single and multi-speed motors are included on the UK Energy Technology List. Please check the ECA scheme website: www.eca.gov.uk at time of purchase for current listing.

Standards and environment

Standards

Standards						
Single phase motors can be manufactured to the international standards listed below:						
Range	International	National standard	North American*			
Standard	IEC	BS	VDE	DIN	NF	NEMA
Outputs	–	BS 5000 part 10	–	DIN 42673, DIN 42677	NF C51-110	MG1 part 10
Performance	IEC 60034-1	BS EN 60034-1	VDE 0530 part 1	–	NF C51-111	MG1 part 12
Dimensions	IEC 60072-1	BS 4999 part 141	–	DIN 42673, DIN 42677	NF C51-105, NF C51-120	MG1 part 4
Mounting	IEC 60034-7	BS EN 60034-7	–	DIN 42950	NF C51-117	MG1 part 4
Degrees of protection	IEC 60034-5	BS EN 60034-5	–	DIN 40050	NF C51-115	MG1-1.26B

standard BS and European specification motor complies
 optional
 BS specification motor complies except flange tolerances to IEC 60072-1 Annex C.1.7 Option 1
 European specification motors
 Motors complying with IEC 60034-1 also comply with many of the national standards of other European countries, eg CEI 203 (Italy), NBN7 (Belgium), NEN 3173 (Netherlands), SEN 2601 01 (Sweden)
 * Motors to NEMA standards have CSA approval and generally comply with Canadian (EEMAC) standards
 Standard motors also meet CSA standard C390 (energy efficient) and USA 'EPAc' legislation

Environment Enclosure

All motors have degrees of IP protection as defined in IEC EN 60034-5.

European directives

Four European directives apply in varying degrees to ac induction motors. Brook Crompton comply in the following manner:

Motor cooling

Motors are cooled in accordance with EN 60034-6. The normal arrangement is IC411 (Totally Enclosed Fan Ventilated) via a fan mounted at the non-drive end. Alternative methods of cooling available on request.

Compliance with European directives applying to AC induction motors				
Directives	Low voltage (LV)	Machinery (MD)	Electromagnetic compatibility (EMC)	ATEX
Reference numbers	73/23/EEC 93/68/EEC	89/392/EEC 91/368/EEC 93/44/EEC 93/68/EEC	89/336/EEC 92/31/EEC 93/68/EEC	94/9/EC
Motor CE marked	Yes	No	No	YES
Standards	EN 60034	Not applicable	EN 60034-1	
Documentation for customers' technical file	Declaration of conformity	Certificate of incorporation	Statement ⁽¹⁾	Declaration of conformity
Safety instructions with every motor	Yes	Yes	Yes	Yes
Comment	Relevant electrical equipment operating between 50 to 1000 volts AC	Statement ⁽²⁾	Component	Hazardous atmosphere equipment - mandatory after July 2003

⁽¹⁾ Motors operating from a correctly applied, sinusoidal (AC) supply meet the requirements of the EMC directive and are within the limits specified in standard EN 60034-1

⁽²⁾ When installed in accordance with our customer safety and installation and maintenance instructions, they can be put into service only when the machinery into which they are being incorporated, has been declared to be in conformity with the machinery directive in accordance with Article 4(2) and Annex IIB of that Directive (98/37/EEC)

Specification

Single phase designs

Dependent on the application we are able to offer different types of single phase motor, these are described as follows:

Permanent capacitor - PDA

- Standard design: Direct-on-line starting only, with any spot voltage between 200-250 volts available. Suitable for fans, blowers and centrifugal pump drives with light starting requirements. Starting torque is between 25% and 55% of full load torque, according to frame size. Clockwise or anticlockwise rotation of the shaft available by re-connection.

- High torque design: Direct-on-line starting, with any spot voltage between 200-250 volts available. Suitable for fans, blowers, centrifugal pumps and compressors requiring a higher starting torque. Starting torque is between 70% and 80% of full load dependent on frame size.

- Variable voltage speed control: For use on variable voltage (thyristor) speed control. Suitable for fan applications. Outputs and frames sizes are detailed on page 9.

Capacitor start - EDA/TDA

Available in either Capacitor Start/Induction Run design (EDA) or Capacitor Start/Capacitor Run design (TDA). Direct-on-line starting with any spot voltage between 200-500 volts available. High starting performances suitable for industrial and agricultural applications of a more demanding nature. Starting torque is between 160% and 300% of full load torque according to frame size. Clockwise or anticlockwise rotation of the shaft available by re-connection.

High pressure washer - TDA

Direct-on-line starting only. Motors are designed with starting characteristics to suit operation from single phase socket outlets even when delivering 2.2kW. Motors are specifically designed to start under the worst possible conditions, i.e. against full back pressure (a condition which should not occur but often does). 110 volt versions are available.

Motors are available with a standard shaft extension or with a female hollow shaft, having one bearing at the non drive end.

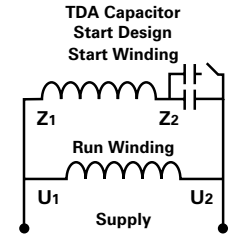
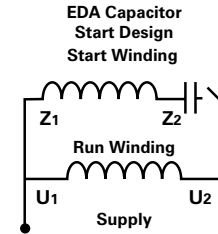
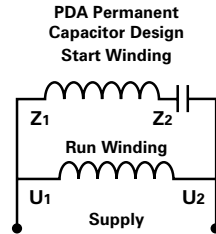

Enclosure

The standard enclosure is designed to give IP55 protection against the harmful ingress of dust and water.

Insulation and temperature rise

All motors are wound with Class F (Dupont) insulation (temperature limit 145°C). Insulation materials include 'NOMEX' meta-aramid paper and 'MYLAR' polyester film. Temperature rise is normally Class B, where Class F rise is utilised, the individual frame sizes are detailed on pages 5-9. ('NOMEX' and 'MYLAR' are registered trade marks of Du Pont.)

Temperature rise	
Class B	80°C
Class F	105°C

Site conditions

Motors will operate satisfactorily in an ambient temperature range of -10°C to +40°C and at altitudes of up to 1000 metres above sea level.

Shafts

All shafts are machined to IEC72 (BS4999 Part 141) (see dimensions on pages 10/12). For ease of fitting, removal or securing fitments, a tapped hole in the drive end is provided as standard on all motor shafts.

Balance

All motors are dynamically balanced to IEC34-14 (BS4999 Part 142) normal balance. Reduced or special balance is available, where centrifugal switch is not fitted.

Stator frame

Stator frames are produced in die-cast aluminium with clean aesthetic styling. Adaptability of mounting/alternative terminal box positions are an important feature of the single phase range.

Terminal box

Customers may specify their preferred position at the time of order or make their own modification at a later stage. Rotating the terminal box in steps of 90° gives the user 4 alternative cable entry positions on all frame sizes, dependent on position and capacitor mounting.

Paint

The paint system, which is totally compatible with modern environmental requirements, provides excellent paint adhesion, maximum corrosion protection and the highest quality finish. Immediately after castings have cooled they are cleaned in a vibratory finisher. A chemical dip prepares the surface and this is followed by cold and hot washing of the components prior to coating with primer. After assembly the finished motor is sprayed with a medium gloss top coat in Water Blue colour – RAL 5021

Rating plate

Motors are fitted with a fully stamped anodised aluminium rating plate.

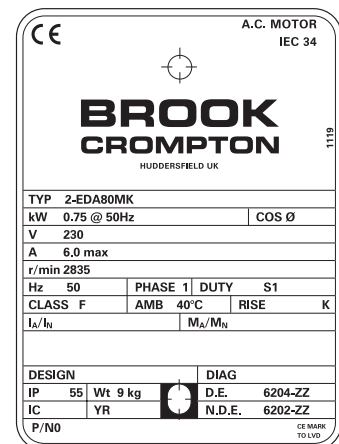

Example of rating plate

Performance data

Capacitor start induction run 3000 min⁻¹ (2 pole)

Rated power P_N kW (hp)	Full load speed in revolutions per minute n min ⁻¹	Frame reference and size Type	Full load current at rated voltage I_N 230 V A	Efficiency η		Power factor Cos ϕ	Full load torque M_N Nm	Direct on line starting torque ratio $\frac{M_A}{M_N}$	Direct on line starting current ratio $\frac{I_A}{I_N}$	Start capacitor μF Start
				1.0 P_N 0.75 P_N 0.5 P_N	1.0 P_N 0.75 P_N 0.5 P_N					
0.18 (0.25)	2850	2-EDA71MG	1.65	61.0 60.0 52.0	0.77 0.67 0.56	0.6	2.2	5.3	55	
0.25 (0.33)	2850	2-EDA71MK	2.3	61.0 60.0 52.0	0.78 0.68 0.58					
0.37 (0.50)	2850	2-EDA71MR	3	68.0 67.0 63.0	0.80 0.70 0.56	1.24	2	4.5	100	
0.55 (0.75)	2810	2-EDA80MF	3.1	64.0 64.0 61.0	0.79 0.68 0.58	1.87	1.4	3.9	100	
0.75 (1.0)	2835	2-EDA80MK	6	68.0 69.0 65.0	0.80 0.72 0.58	2.53	1.9	4.37	100	
1.1 (1.5)	2875	2-EDA90SJ	8.8	71.5 71.0 67.0	0.76 0.67 0.53	3.65	1.5	4.7	100	
1.5 (2.0)	2865	2-EDA90LS	11.2	75.5 77.0 74.5	0.79 0.70 0.57	5	1.7	5	100	

Capacitor start induction run 1500 min⁻¹ (4 pole)

P_N kW (hp)	n min ⁻¹	Type	I_N 230 V A	η		Cos ϕ	M_N Nm	$\frac{M_A}{M_N}$	$\frac{I_A}{I_N}$	μF Start
				1.0 P_N 0.75 P_N 0.5 P_N	1.0 P_N 0.75 P_N 0.5 P_N					
0.12 (0.25)	1430	2-EDA71MG	1.75	47.0 43.0 34.0	0.63 0.54 0.45	0.8	2.5	4	55	
0.18 (0.25)	1410	2-EDA71MK⁽¹⁾	2.3	51.0 49.0 42.0	0.66 0.57 0.48					
0.25 (0.33)	1420	2-EDA71MR⁽¹⁾	2.8	60.0 58.0 52.0	0.64 0.55 0.44	1.68	2.4	4	100	
0.37 (0.50)	1430	2-EDA80MG	4.2	58.0 56.0 51.0	0.67 0.58 0.45	2.5	2.1	4.1	100	
0.55 (0.75)	1430	2-EDA80MR	6	61.0 58.0 50.0	0.67 0.57 0.49	3.7	2	5.1	100	
0.75 (1.0)	1420	2-EDA90LK⁽¹⁾	8	60.0 58.0 54.0	0.68 0.60 0.49	5	2.3	4.1	100	
1 (1.34)	1420	2-EDA90LT⁽¹⁾	9.75	65.0 64.0 57.0	0.69 0.60 0.49	6.7	1.9	4.5	100	

⁽¹⁾ Class F temperature rise

Performance data

Capacitor start capacitor run 3000 min⁻¹ (2 pole)

<i>Rated power</i>	<i>Full load speed in revolutions per minute</i>	<i>Frame reference and size</i>	<i>Full load current at rated voltage</i>	<i>Efficiency</i>	<i>Power factor</i>	<i>Full load torque</i>	<i>Direct on line starting torque ratio</i>	<i>Direct on line starting current ratio</i>	<i>Start capacitor</i>	<i>Run capacitor</i>
P_N kW (hp)	n min ⁻¹	Type	I_N 230 V A	η $1.0 P_N$ $0.75 P_N$ $0.5 P_N$	$\cos \phi$ $1.0 P_N$ $0.75 P_N$ $0.5 P_N$	M_N Nm	$\frac{M_A}{M_N}$	$\frac{I_A}{I_N}$	μF Start	μF Run
0.25 (0.33)	2830	2-TDA71MG	1.6	$\left\{ \begin{matrix} 67.0 & 0.99 \\ 64.0 & 0.98 \\ 55.0 & 0.97 \end{matrix} \right\}$		0.84	1.3	4.4	55	10
0.37 (0.50)	2870	2-TDA71MK	2.2	$\left\{ \begin{matrix} 74.0 & 0.99 \\ 73.0 & 0.98 \\ 62.0 & 0.96 \end{matrix} \right\}$		1.23	1.9	6.2	55	10
0.55 (0.75)	2850	2-TDA71MR	3.5	$\left\{ \begin{matrix} 69.0 & 0.99 \\ 65.0 & 0.98 \\ 56.0 & 0.97 \end{matrix} \right\}$		1.84	1.7	5	100	20
0.75 (1.0)	2810	2-TDA80MF	4.7	$\left\{ \begin{matrix} 73.0 & 0.97 \\ 72.0 & 0.93 \\ 67.0 & 0.84 \end{matrix} \right\}$		2.55	1.9	4.3	100	15
1.1 (1.5)	2830	2-TDA80MK	6.8	$\left\{ \begin{matrix} 74.5 & 0.94 \\ 74.0 & 0.90 \\ 67.5 & 0.80 \end{matrix} \right\}$		3.71	1.8	4.3	100	20
1.5 (2.0)	2860	2-TDA90SJ	9	$\left\{ \begin{matrix} 79.5 & 0.91 \\ 70.5 & 0.86 \\ 78.0 & 0.77 \end{matrix} \right\}$		5.01	2.5	5.75	200	20
2.2 (3.0)	2870	2-TDA90LS	13.2	$\left\{ \begin{matrix} 81.0 & 0.90 \\ 81.5 & 0.84 \\ 79.0 & 0.74 \end{matrix} \right\}$		7.32	2.1	5.15	200	25
3 (4.0)	2880	TDA100LZ	19.54 ⁽¹⁾	$\left\{ \begin{matrix} 75.0 & 0.89 \\ 74.0 & 0.82 \\ 72.0 & 0.70 \end{matrix} \right\}$		9.5	1.6	5.8	200	50

⁽¹⁾ $I_N = 240V$

Capacitor start capacitor run 1500 min⁻¹ (4 pole)

P_N kW (hp)	n min ⁻¹	Type	I_N 230 V A	η $1.0 P_N$ $0.75 P_N$ $0.5 P_N$	$\cos \phi$ $1.0 P_N$ $0.75 P_N$ $0.5 P_N$	M_N Nm	$\frac{M_A}{M_N}$	$\frac{I_A}{I_N}$	μF Start	μF Run
0.18 (0.25)	1430	2-TDA71MJ	1.3	$\left\{ \begin{matrix} 61.0 & 0.99 \\ 57.0 & 0.99 \\ 45.0 & 0.97 \end{matrix} \right\}$		1.2	2	5.2	55	10
0.25 (0.33)	1420	2-TDA71MK	1.7	$\left\{ \begin{matrix} 65.0 & 0.98 \\ 60.0 & 0.97 \\ 49.0 & 0.95 \end{matrix} \right\}$		1.68	1.8	5	55	15
0.37 (0.50)	1410	2-TDA71MR	2.4	$\left\{ \begin{matrix} 68.0 & 0.90 \\ 67.0 & 0.99 \\ 57.0 & 0.98 \end{matrix} \right\}$		2.51	2	5	100	20
0.55 (0.75)	1440	2-TDA80MG	3.4	$\left\{ \begin{matrix} 72.0 & 0.99 \\ 68.5 & 0.99 \\ 58.0 & 0.98 \end{matrix} \right\}$		3.63	1.85	5	100	20
0.75 (1.0)	1430	2-TDA80MR	4.5	$\left\{ \begin{matrix} 73.5 & 0.98 \\ 70.0 & 0.98 \\ 60.0 & 0.96 \end{matrix} \right\}$		5	2	4.8	100	25
1.1 (1.5)	1430	2-TDA90SK	6.35	$\left\{ \begin{matrix} 77.5 & 0.98 \\ 77.5 & 0.97 \\ 71.0 & 0.96 \end{matrix} \right\}$		7.3	2.15	5.6	200	30
1.5 (2.0)	1430	2-TDA90LT	8.7	$\left\{ \begin{matrix} 80.0 & 0.94 \\ 80.0 & 0.92 \\ 76.0 & 0.88 \end{matrix} \right\}$		10	2	5.1	200	30
2.2 (3.0)	1440	TDA100LZ	15 ⁽¹⁾	$\left\{ \begin{matrix} 75.0 & 0.85 \\ 73.0 & 0.79 \\ 69.0 & 0.66 \end{matrix} \right\}$		14	2	5.35	200	25

⁽¹⁾ $I_N = 240V$

Performance data

Capacitor start capacitor run 1000 min⁻¹ (6 pole)

P_N kW (hp)	n min ⁻¹	Type	Full load current at rated voltage		Efficiency		Power factor	Full load torque M_N Nm	Direct on line starting torque ratio $\frac{M_A}{M_N}$	Direct on line starting current ratio $\frac{I_A}{I_N}$	Start capacitor μF Start	Run capacitor μF Run
			230 V A	I_N	η $1.0 P_N$ $0.75 P_N$ $0.5 P_N$	$\cos \phi$ $1.0 P_N$ $0.75 P_N$ $0.5 P_N$						
0.37 (0.50)	945	2-TDA90SK	2.5		66.0 60.0 46.0	0.99 0.98 0.91		3.75	2.6	5.8	100	20
0.55 (0.75)	945	2-TDA90LT	3.7		68.5 62.0 50.0	0.95 0.95 0.91		5.5	2.9	6.8	200	30
0.75 (1.0)	940	TDA100LZ	7.3		62.0 62.0 57.0	0.72 0.64 0.53		7.2	2.4	4	100	12

High pressure washer motors

Capacitor start, high output, low running current 3000 min⁻¹ (2 pole) - 220/240V

P_N kW (hp)	n min ⁻¹	Type	I_N		Efficiency		$\cos \phi$	M_N Nm	$\frac{M_A}{M_N}$	$\frac{I_A}{I_N}$	μF Start	μF Run
			220 V A	240 V A	η $1.0 P_N$ $0.75 P_N$ $0.5 P_N$	$1.0 P_N$ $0.75 P_N$ $0.5 P_N$						
2.2 (3.0)	2900	TDA100LZ	13.4	12.3	78.0 76.0 72.0	0.96 0.95 0.93		7.2	1.75	5.75	200	25

Capacitor start, high output, low running current 1500 min⁻¹ (4 pole) - 220/240V

P_N kW (hp)	n min ⁻¹	Type	I_N		Efficiency		$\cos \phi$	M_N Nm	$\frac{M_A}{M_N}$	$\frac{I_A}{I_N}$	μF Start	μF Run
			220 V A	240 V A	η $1.0 P_N$ $0.75 P_N$ $0.5 P_N$	$1.0 P_N$ $0.75 P_N$ $0.5 P_N$						
1.8 (2.5)	1440	TDA100LZ	11.2	10.3	77.0 74.0 67.0	0.95 0.92 0.86		11.9	2.2	5.8	200	25
2.2 (3.0)	1430	TDA100LZ	13.6	12.5	78.0 76.0 71.0	0.96 0.94 0.98		14.7	1.8	4.8	200	25

Capacitor start, high output, low running current 1500 min⁻¹ (4 pole) - 110V

P_N kW (hp)	n min ⁻¹	Type	I_N		Efficiency		$\cos \phi$	M_N Nm	$\frac{M_A}{M_N}$	$\frac{I_A}{I_N}$	μF Start	μF Run
			110 V A		η $1.0 P_N$ $0.75 P_N$ $0.5 P_N$	$1.0 P_N$ $0.75 P_N$ $0.5 P_N$						
1.8 (2.5)	1440	TDA100LZ	24.0		73.0 72.0 66.0	0.95 0.93 0.89		11.9	1.4	4.2	2 x 400	2 x 60
2.2 (3.0)	1430	TDA100LZ	30.0		73.0 73.0 69.0	0.92 0.91 0.81		14.7	1.35	4.3	2 x 135	2 x 60

Performance data

Permanent capacitor - standard design 3000 min⁻¹ (2 pole)

P _N kW (hp)	n min ⁻¹	Type	I _N 230 V A	Efficiency		Power factor	Full load torque M _N Nm	Direct on line starting torque ratio $\frac{M_A}{M_N}$	Direct on line starting current ratio $\frac{I_A}{I_N}$	Start & run capacitor μF Start & run
				η 1.0 P _N 0.75 P _N 0.5 P _N	Cos Ø 1.0 P _N 0.75 P _N 0.5 P _N					
0.12 (0.166)	2870	PDA63SF	1.08	{ 51.0 0.95 46.0 0.92 35.0 0.87 }		0.38	0.3	2.75	15	
0.18 (0.25)	2870	PDA63SF	1.25	{ 64.0 0.98 59.0 0.97 49.0 0.94 }		0.57	0.4	3	15	
0.25 (0.33)	2830	2-PDA71MG	1.6	{ 67.0 0.99 64.0 0.98 55.0 0.97 }		0.84	0.5	3.3	10	
0.37 (0.50)	2870	2-PDA71MK	2.2	{ 74.0 0.99 73.0 0.98 62.0 0.96 }		1.23	0.4	3.5	10	
0.55 (0.75)	2850	2-PDA71MR	3.5	{ 69.0 0.99 65.0 0.98 56.0 0.97 }		1.84	0.4	3.5	20	
0.75 (1.0)	2810	2-PDA80MF	4.7	{ 73.0 0.97 72.0 0.93 67.0 0.84 }		2.55	0.25	3.7	15	
1.1 (1.5)	2830	2-PDA80MK	6.8	{ 74.5 0.94 74.0 0.90 67.5 0.80 }		3.71	0.3	3.4	20	
1.5 (2.0)	2820	2-PDA90SJ	9.2	{ 71.0 0.99 69.0 0.98 62.0 0.97 }		5.08	0.3	3.8	30	
2.2 (3.0)	2870	2-PDA90LS	13.2	{ 81.0 0.90 81.5 0.84 79.0 0.74 }		7.32	0.2	4.95	25	

Permanent capacitor - standard design 1500 min⁻¹ (4 pole)

P _N kW (hp)	n min ⁻¹	Type	I _N 230 V A	Efficiency		Power factor	Full load torque M _N Nm	Direct on line starting torque ratio $\frac{M_A}{M_N}$	Direct on line starting current ratio $\frac{I_A}{I_N}$	Start & run capacitor μF Start & run
				η 1.0 P _N 0.75 P _N 0.5 P _N	Cos Ø 1.0 P _N 0.75 P _N 0.5 P _N					
0.09 (0.125)	1420	PDA63SF	0.81	{ 51.0 0.95 46.0 0.92 35.0 0.90 }		0.57	0.5	2	15	
0.12 (0.166)	1420	PDA63SG	1.1	{ 51.0 0.93 44.0 0.91 35.0 0.87 }		0.76	0.45	2.75	15	
0.18 (0.25)	1430	2-PDA71MJ	1.3	{ 61.0 0.99 57.0 0.99 45.0 0.97 }		1.2	0.5	2.9	10	
0.25 (0.33)	1420	2-PDA71MK	1.7	{ 65.0 0.98 60.0 0.97 49.0 0.95 }		1.68	0.4	3	15	
0.37 (0.50)	1410	2-PDA71MR	2.4	{ 68.0 0.99 67.0 0.99 57.0 0.98 }		2.51	0.4	3.5	20	
0.55 (0.75)	1410	2-PDA80MG	3.5	{ 69.0 0.99 66.0 0.99 56.0 0.98 }		3.73	0.45	3	20	
0.75 (1.0)	1420	2-PDA80MR	4.5	{ 73.5 0.99 70.0 0.99 60.0 0.98 }		5.05	0.35	3.5	25	
1.1 (1.5)	1430	2-PDA90SK	6.3	{ 77.5 0.99 75.0 0.99 64.0 0.97 }		7.3	0.4	3.5	40	
1.5 (2.0)	1435	2-PDA90LT	8.5	{ 78.0 0.99 74.0 0.99 65.0 0.97 }		9.9	0.3	4.1	50	

Performance data

Permanent capacitor - high torque design 1500 min⁻¹ (4 pole)

Rated power P_N kW (hp)	Full load speed in revolutions per minute n min ⁻¹	Frame reference and size Type	Full load current at rated voltage I_N 230 V A	Efficiency η		Power factor Cos ϕ		Full load torque M_N Nm	Direct on line starting torque ratio $\frac{M_A}{M_N}$	Direct on line starting current ratio $\frac{I_A}{I_N}$	Start & run capacitor μ F
				1.0 P_N 0.75 P_N 0.5 P_N	1.0 P_N 0.75 P_N 0.5 P_N	1.0 P_N 0.75 P_N 0.5 P_N	1.0 P_N 0.75 P_N 0.5 P_N				
0.37 (0.50)	2870	2-PDA80MG	2.8	59.0 50.0 40.0	0.99 0.98 0.97	2.5	0.85	3.2	25		
0.5 (0.67)		2-PDA80MG⁽¹⁾	3.7	59.0 50.0 40.0	0.98 0.97 0.95	3.5	0.85	2.5	30		
0.67 (0.9)		2-PDA80MR⁽¹⁾	4.5	59.0 50.0 40.0	0.99 0.99 0.98	5.05	0.35	3.5	25		
0.75 (1.0)		2-PDA90SK	5.1	59.0 50.0 40.0	0.98 0.97 0.95	5	0.75	3.7	40		
0.9 (1.21)		2-PDA90LK⁽¹⁾	5.7	59.0 50.0 40.0	0.99 0.99 0.97	6	0.7	4.15	40		
1.1 (1.5)		2-PDA90LT⁽¹⁾	7	59.0 50.0 40.0	0.99 0.99 0.97	7.4	0.7	4.2	50		

⁽¹⁾ Class F temperature rise

Permanent capacitor for speed control by voltage variation 3000 min⁻¹ (2 pole)

P_N kW (hp)	n min ⁻¹	Type	I_N 230 V A	η		Cos ϕ		M_N Nm	$\frac{M_A}{M_N}$	$\frac{I_A}{I_N}$	μ F Start & run
				1.0 P_N 0.75 P_N 0.5 P_N	1.0 P_N 0.75 P_N 0.5 P_N	1.0 P_N 0.75 P_N 0.5 P_N	1.0 P_N 0.75 P_N 0.5 P_N				
0.37 (0.50)	2770	2-PDA80MG	2.35	67.0 64.0 61.0	0.99 0.99 0.98	1.3	0.4	4.2	10 ⁽¹⁾		

⁽¹⁾ Some high inertia applications may require a 15 μ F capacitor

Permanent capacitor for speed control by voltage variation 1500 min⁻¹ (4 pole)

P_N kW (hp)	n min ⁻¹	Type	I_N 230 V A	η		Cos ϕ		M_N Nm	$\frac{M_A}{M_N}$	$\frac{I_A}{I_N}$	μ F Start & run
				1.0 P_N 0.75 P_N 0.5 P_N	1.0 P_N 0.75 P_N 0.5 P_N	1.0 P_N 0.75 P_N 0.5 P_N	1.0 P_N 0.75 P_N 0.5 P_N				
0.37 (0.50)	1370	2-PDA80MG	2.5	64.0 58.0 46.0	0.95 0.89 0.84	2.6	0.75	2.6	25		
0.75 (1.0)	1380	2-PDA90SK	4.65	71.0 68.0 53.0	0.95 0.88 0.79	5	0.65	2.8	40		
1 (1.34)	1390	2-PDA90LT	6.1	71.0 66.0 55.0	0.97 0.94 0.89	6.9	0.6	3.5	50		
1.1 ⁽²⁾ (1.5)	1380	2-PDA90LT	6.5	71.0 68.0 58.0	0.99 0.97 0.91	7.6	0.55	3.3	50		

⁽¹⁾ Identical to 1kW, but increased output may be available on special applications

Dimensions

Foot, flange and face mounting - frame sizes 63 - 100L

IM B3
IM 1001
Mounting options

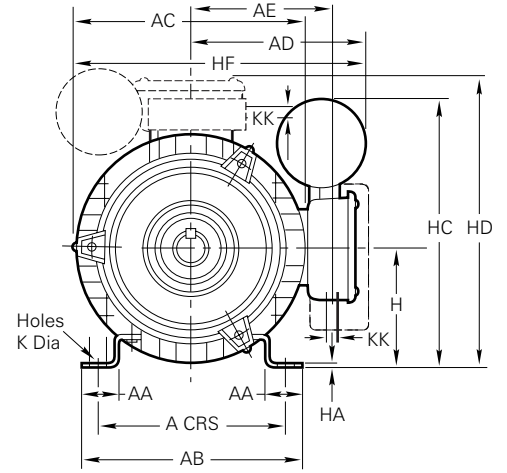
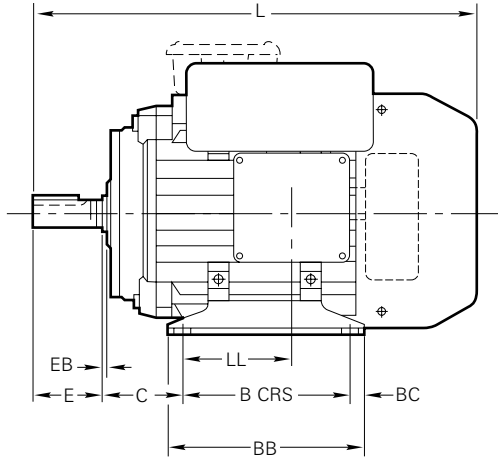

IM B5/IM B35
IM 3001/IM 2001
Mounting options

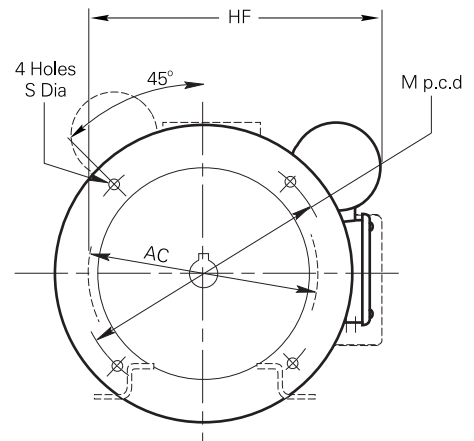
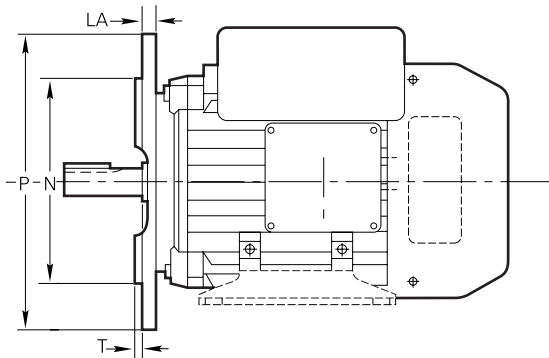

IM B14/IM B34
IM 3601/IM 2101
Mounting options

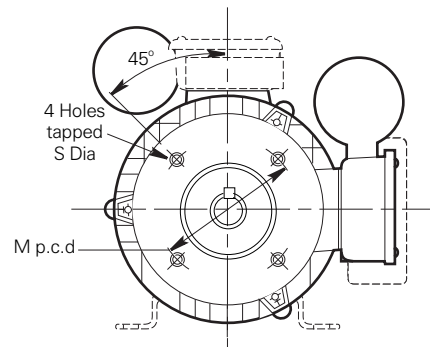
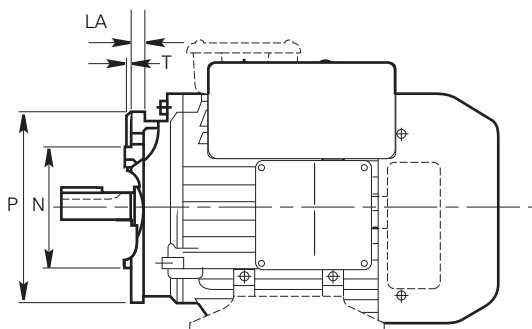

Foot, flange and face mounting - frame sizes 63 - 100L

Type	General																	
	A	B	C	H	K	L	LL	AA	AB	AC	AD	AE	BB	BC	HA	HC	HF	KK
63S	100	80	40	63	7	207	74	19	119	126	127	-	100	10	2	169	190	20
71M	112	90	45	71	7	238	116.5	19	131	140	126	95.5	110	10	2	197	165.5	20
80M	125	100	50	80	10	278	75	27	157	160	145	102	127	13.5	4	208	224	20
90S	140	100	56	90	10	322	100	28	164	178	153	110	150	13.5	4	218	242	20
90L	140	125	56	90	10	322	100	28	164	178	153	110	150	13.5	4	218	242	20
100L	160	140	63	100	12	368	117	28	184	208	125	120	170	15	4	250	-	20

Type	IM B5 mounting						IM B14 mounting					
	M	N	P	S	T	LA	M	N	P	S	T	LA
63S	115	95	140	10	3	7	75	60	90	M5	2.5	7
71M	130	110	160	10	3.5	7	85	70	105	M6	2.5	9
80M	165	130	200	12	3.5	12	100	80	120	M6	3	9
90S	165	130	200	12	3.5	10	115	95	140	M8	3	9
90L	165	130	200	12	3.5	10	115	95	140	M8	3	9
100L	215	180	250	15	4	11	130	110	160	M8	3.5	22

Type	Shaft						
	D	E	F	G	GD	EB	DH
63S	11	23	4	8.5	4	1.5	M4 x 10
71M	14	30	5	11	5	6.5	M5 x 12.5
80M	19	40	6	15.5	6	1.5	M6 x 16
90S/L	24	50	8	20	7	1.5	M8 x 19
100L	28	60	8	23.9	7	1.5	M10 x 22

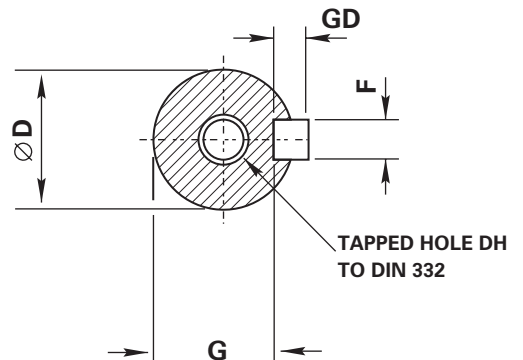

Dimensions

Rod/pad mounting - frame sizes 63 - 100L

IM B30, IM V30, IM V31
IM 9201, IM 9211,
IM 9231

Mounting options

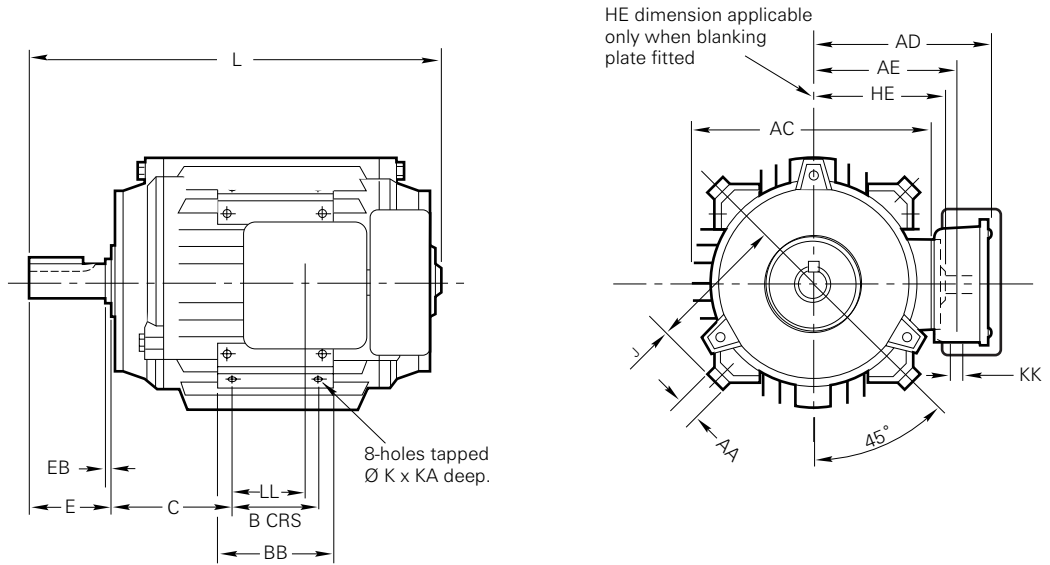

Type	General													
	B	C	J	K	L	LL	AA	AC	AD	AE	BB	HE	KA	KK
63S	90	40	70	M8	180	37	18	126	127	76	119	73	12	20
71M	90	45	83.5	M8	203.5	116.5	17	140	126	95.5	107	84	12	20
80M	90	55	95	M12	253	70	23	160	145	102	113	102	14	20
90S/L	90	73.5	103	M12	299	83	24	178	153	110	114	110	13	20
100L	100	83	112.5	M12	327	97	20	195	125	120	120	113	15	20

Type	Shaft						
	D	E	F	G	GD	EB	DH
63S	11	23	4	8.5	4	10	M4 x 10
71M	14	30	5	11	5	20	M5 x 12.5
80M	19	40	6	15.5	6	32	M6 x 16
90S/L	24	50	8	20	7	40	M8 x 19
100L	28	60	8	23.9	7	50	M10 x 22

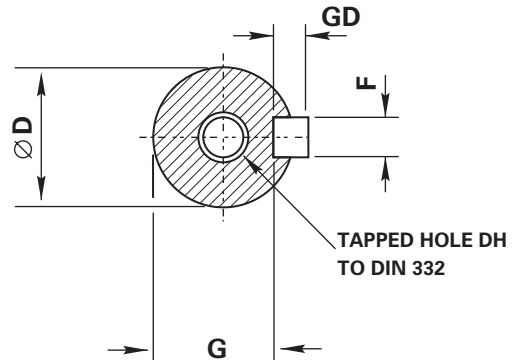

Mounting options

Horizontal shaft:

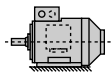

IM B3
IM 1001
foot mounted

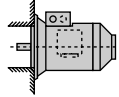

IM B5
IM 3001
flange at DE
no feet



IM B6
IM 1051
foot wall mounted with
feet on left-hand side
when viewed from DE



IM B7
IM 1061
foot wall mounted with
feet on right-hand side
when viewed from DE



IM B8
IM 1071
ceiling mounted
with feet
above motor

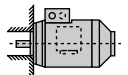

IM B14
IM 3601
face at DE
no feet

Vertical shaft:

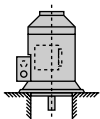

IM V1
IM 3011
flange at DE
shaft down
no feet

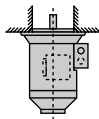

IM V3
IM 3031
flange at DE
shaft up
no feet

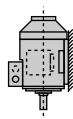

IM V5
IM 1011
vertical foot
wall mounted
shaft down

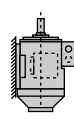

IM V6
IM 1031
vertical foot
wall mounted
shaft up

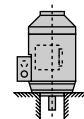

IM V18
IM 3611
face at DE
shaft down
no feet

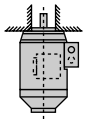

IM V19
IM 3631
face at DE
shaft down
no feet

Approximate shipping specifications

Type	Net weight (kg)	Gross weight (kg)	Cubage (m ³)
63	5	5.4	0.010
71	6	6.4	0.010
80	9	10	0.020
90S	12.5	13.5	0.030
90L	14.5	15.5	0.030
100L	19	21	0.038

Technical information: Mechanical

Bearings and greasing arrangements

Bearings are pre-packed with a grease type dependant on frame size and re-greasing facility as detailed in table opposite:

Standard and re-greasing facilities		
Type	Standard grease	Re-greasing facility
63 - 100	EA6 Polyurea	Available on request

Bearing references and oil seals for horizontally-mounted motors only					
Type	Polarity	Bearings ⁽¹⁾		Oil seals ⁽²⁾	
		Drive end	Non-drive end	Drive end	Non-drive end
63	All	6202ZZ	6202ZZ	15 x 24 x 5	15 x 24 x 5
71	All	6003ZZ	6003ZZ	17 x 28 x 6	17 x 28 x 6
80	All	6204ZZ	6202ZZ	20 x 30 x 7	15 x 24 x 5
90	All	6205ZZ	6205ZZ	25 x 35 x 7	17 x 28 x 6
100	All	6206ZZ	6206ZZ	30 x 42 x 7	20 x 30 x 7

⁽¹⁾ Frame sizes 63 to 90 have bearings with CN clearances, frame sizes 100 have bearings with C3 clearance 'medium' series
⁽²⁾ Sizes given are in mm, and represent bore x outside diameter x width.
 Material: Nitrile rubber and Silicon rubber

Grease life expected at 80°C bearing temperature x 10 ³ hours								
Type	3000 min ⁻¹		1500 min ⁻¹		1000 min ⁻¹		750 min ⁻¹	
	Horizontal	Vertical	Horizontal	Vertical	Horizontal	Vertical	Horizontal	Vertical
63	22	22	32	32	35	35	35	35
71	22	22	32	32	35	35	35	35
80	22	22	32	32	35	35	35	35
90	22	22	32	32	35	35	35	35
100	26	26	35	35	35	35	35	35

Axial and radial loads

Maximum permissible external axial thrust and radial loads in Newtons (N)								
Type	Poles	Horizontal shaft		Vertical shaft				Maximum permissible radial load at end of shaft (standard mounting)
		Load towards motor	Load away from motor	Shaft up		Shaft down		
				Load towards motor	Load away from motor	Load towards motor	Load away from motor	
63	2	294	383	284	432	314	412	196
	4	392	471	383	491	402	451	284
	6	461	530	451	540	471	520	304
71	2	167	314	147	334	177	304	255
	4	216	363	196	392	235	535	284
	6	245	402	226	422	275	383	304
80	2	275	441	245	481	294	432	638
	4	373	549	343	569	392	520	785
	6	441	618	412	647	471	589	903
90	2	412	638	294	598	373	520	824
	4	540	765	402	716	471	628	903
	6	638	863	491	814	589	716	981
100	2	853	853	932	932	814	814	1207
	4	1010	1010	1118	1118	961	961	1393
	6	1207	1207	1295	1295	1265	1265	1530

All figures are based on L10aah life of 20,000 hours
 Lna = adusted L10 life taking account of reliability, material improvements, lubrication conditions

Performance data – page notes

Permanent capacitor DOL starting (BS EN 60034-12 Design N)

Typical speed/current curve

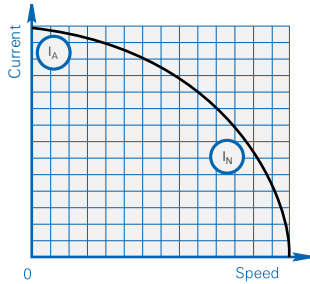

Typical speed/torque curve

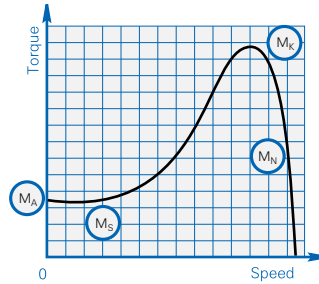

- (I_A) Starting current
- (I_N) Full load current
- (M_A) Starting torque
- (M_S) Pull up torque
- (M_K) Pull out torque
- (M_N) Full load torque

Torque/speed curves for specific motors can be supplied on request.

Performance figures are subject to IEC tolerances.

Capacitor start DOL starting (BS EN 60034-12 Design N)

Typical speed/current curve

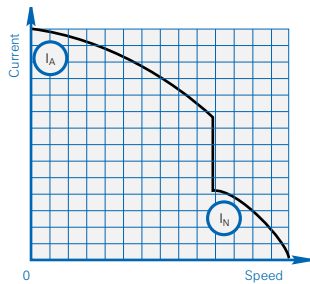

Typical speed/torque curve

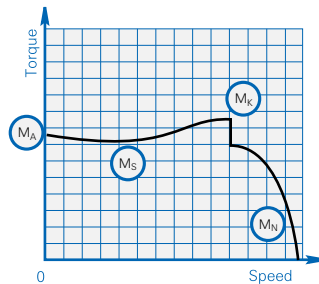

Dimensions – page notes

Flange	Face	Tolerances to IEC 60072-1 Annex C.1.7 Option 1	
Dim N	Dim N	Tol	Limits
	60 and 80	j6	+0.012 -0.007
95 and 110	95 and 110	j6	+0.013 -0.009
130 and 180	130	j6	+0.014 -0.011
230		h6	+0.016 -0.013

Shaft	British and European	
Dim D	Tol	Limits
11 to 18	j6	+0.008 -0.003
19 to 28	j6	+0.009 -0.004
32 to 48	k6	+0.018 +0.002

All dimensions in millimetres

Drain holes are available on request.

Cable entry can be arranged in any one of four positions at 90° intervals

B5 mounted motors have suffix 'D' in the frame reference, eg 2-PDA80MC-D and B35 mounted motors have suffix 'H' in the frame reference, eg 2-PDA80MC-H

B14 mounted motors have suffix 'C' in the frame reference, eg, 2-PDA80MC-C and B3/B14 mounted motors have suffix 'H' in the frame reference, eg 2-PDA80MC-H

Pad mounted motors have a suffix 'P' in the frame reference, eg 2-PDA80MC-P and rod mounted motors have suffix 'R' in the frame reference, eg 2-PDA80MC-R.

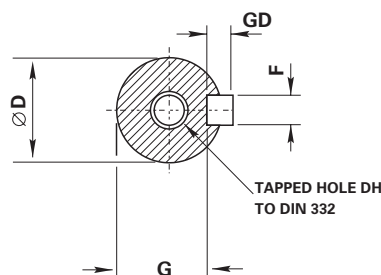

Dimensions should not be used for installation purposes unless specially endorsed.

The position and mounting arrangement of the capacitor housings may vary dependent on frame size frame and output.

Capacitor start, capacitor run motors have 1 or 2 capacitors fitted in addition to those shown on the diagrams.

63 frame pad/rod mounting available only without terminal box.

Rotating Electrical Machines

Worldwide sales and service network

Every care has been taken to ensure the accuracy of the information contained in this publication, but, due to a policy of continuous development and improvement the right is reserved to supply products which may differ slightly from those illustrated and described in this publication

For the most recent version of any Brook Crompton catalogue/leaflet, please refer to www.brookcrompton.com



**BROOK
CROMPTON**

Brook Crompton
St Thomas' Road, Huddersfield
West Yorkshire HD1 3LJ UK
Tel: +44 (0) 1484 557200
Fax: +44 (0) 1484 557201
E-mail: csc@brookcrompton.com
Internet: www.brookcrompton.com

Printed in England
nt122/08/03 2227E Issue 1.1e
© Copyright 2003. Brook Crompton. All rights reserved.