



Keeping Industry Turning

W Aluminium AC motors

Frame sizes 63 to 180



**BROOK
CROMPTON** 
Keeping Industry Turning

20112E iss 5

WOLONG
Power your future

Introduction

2

W Aluminium specification

Specification		
	Standard product	Option
Frame sizes	63 - 180	-
Enclosure	IP55	IP56, IP65, IP66
Mounting option	Foot (B3), Flange (B5), Face (B14) or Pad (B30)	Foot & Flange (B35), Foot & Face (B34)
Terminal box position	Top	Right hand side, left hand side
Voltage	3 kW and below: 230 / 400 4 kW and above: 400 / 690	-
Frequency	50 Hz	60 Hz
Cooling	IC411	IC410, IC416 & IC418
Bearing location	Non Drive end	Drive end
Lubrication	63 - 180 double-shielded bearings	80 - 180 regreasing
Insulation	class F	class H
Temperature rise	class B	class F
Paint colour	water blue (RAL 5021)	on request
Fan cover	Steel	-
Thermal protection	-	63 - 180
Anti condensation heaters	-	63 - 180
Drain holes	160 - 180	63 - 132
Inverter Duty (with derate)	Variable Torque: 10:1 Constant Torque: 2:1	- Alternative speed range
Ambient temperature	-20°C to +40°C	-30°C to +60°C
AC & DC brake option	63 - 180	-
Brake kit friendly *	63 - 132	-

The above specification and options give a brief summary of features available for the W Aluminium range.

For a full listing of optional features, please contact Brook Crompton sales.

* Brake kit friendly indicates motor can be fitted with a brake from stock

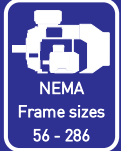
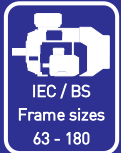

Brook Crompton Keeping Industry Turning

Brook Crompton, the original innovator in electric motor development, is a leading provider of energy efficient electric motors.

With over 110 years' technical & design expertise, UK-based Brook Crompton delivers consistently reliable electric motors to a global market.

Trusted to power limitless industrial activities across diverse market sectors, the robust design of Brook Crompton's electric motors drives fans, pumps, compressors, conveyors and more, every second, of every day, of every year.

Renowned for their adaptability, Brook Crompton's extensive motor stock can be modified to suit the needs of different market sectors, with technical support from the company's knowledgeable team readily available to ensure the correct selection of motors for any application.

For bespoke situations and complete flexibility, Brook Crompton will design and manufacture to meet individual customer specifications.

Brook Crompton has a long-standing reputation for efficient customer service, supporting customers worldwide through its global network. Specialist Brook Crompton Motor Centres operate alongside approved product distributors throughout the UK, mainland Europe, Middle East, Canada, USA, and Asia Pacific.

Shaping the future of electric motors, Brook Crompton is focused on the development of new products that improve energy efficiency, offer lower cost of ownership throughout the motor lifetime and reduce environmental impact.

Brook Crompton, the original innovator in electric motors.

Quality assurance

Stringent quality procedures are observed from first design to finished product in accordance with the ISO 9001 documented quality systems.

All factories have been assessed to meet these requirements.

W Aluminium range

The Brook Crompton W motor range covers products with outputs from 0.12kW up to 22kW in frame sizes 63 to 180.

They are suitable for use in a diverse range of applications. Many applications often have adverse operating conditions including repeated starting and occasional overloading, the W range is well suited to these situations. A virtual 'go anywhere' motor, this aluminium range has a full 3-year guarantee.

Multi-Mount

By simply changing the position of the feet, the user is able to obtain right, left or top mounted terminal box positions.

The standard endshield can be removed and fitted with either a D flange or C face for alternative mounting options.

Benefits include:

- high reliability for long life
- low noise levels
- cool running for long insulation life
- Eurovoltage: 400V ±10%
- high torque with smooth acceleration
- ease of maintenance
- IP55 protection
- 4-position cable entry
- multi-mount for adaptability



Standards, environment & efficiency

Standards

The W range of motors are manufactured to the international standards listed below:

Standards			
Motors of cast iron construction can be manufactured to the following international standards listed below:			
Standard	IEC	EN	BS
Outputs	IEC 60072-1	EN 60072-1	BS EN 500347
Performance	IEC 60034-1	EN 60034-1	BS EN 60034-1
Dimensions	IEC 60072-1	EN 60072-1	BS EN 500347 / BS 4999-141
Mounting	IEC 60034-7	EN 60034-7	BS EN 60034-7
Degrees of protection	IEC 60034-5	EN 60034-5	BS EN 60034-5
Starting	IEC 60034-12	EN 60034-12	BS EN 60034-12
Noise	IEC 60034-9	EN 60034-9	BS EN 60034-9
Efficiency	IEC 60034-30	EN 60034-30	BS EN 60034-30

Motors complying with IEC 60034-1 also comply with many of the national standards of other European countries.

Environment Enclosure

All motors have degrees of IP protection as defined in EN 60034-5.

The standard arrangement is IP55.

See Specification on page 2 for alternatives.

Motor cooling

Motors are cooled in accordance with EN 60034-6.

The standard arrangement is IC411 (Totally Enclosed Fan Ventilated) via a fan mounted at the non-drive end.

See Specification on page 2 for alternatives.

European directives and regulations

Compliance with European Directives & Regulations applying to AC induction motors				
Directives / Regulation	Low voltage (LV)	Machinery (MD)	Electromagnetic compatibility (EMC)	Ecodesign regulation (ErP)
Reference numbers	2014/35/EU	2006/42/EC ⁽³⁾	2014/30/EU	2019/1781 ⁽⁴⁾
Motor CE / UKCA* marked	Yes	No	No	Yes
Standards	EN 60034	Not applicable	EN 60034-1	EN 60034-30
Documentation for customers technical file	Declaration of conformity	Declaration of incorporation	Statement ⁽¹⁾	Declaration of conformity
Safety instructions with every motor	Yes	Yes	Yes	-
Comment	Relevant electrical equipment operating between 50 to 1000 volts AC	Statement ⁽²⁾	Component	Minimum efficiency levels (see Ecodesign requirements AC induction motors below)

* UKCA marked in accordance to the relevant Statutory Instruments and Designated Standards, with equivalence to the EU regulations quoted above.

⁽¹⁾ Motors operating from a correctly applied, sinusoidal (AC) supply meet the requirements of the EMC directive and are within the limits specified in standard EN 60034-1

⁽²⁾ When installed in accordance with our customer safety and installation and maintenance instructions, they can be put into service only when the machinery into which they are being incorporated, has been declared to be in conformity with the machinery directive in accordance with Article 6 (2) and Annex II, Part 1, Section B.

⁽³⁾ Machinery Directive 2006/42/EC to be repealed in January 2027, replaced by Regulation (EU) 2023/1230.

⁽⁴⁾ And amending Regulation (EU) 2021/341.

Ecodesign requirements AC induction motors

Ecodesign regulation [EU] 2019/1781, was introduced in two stages, stage one came into effect on the 1st July 2021, the second stage two years later on the 1st July 2023.

Stage one:

Stage one - 1st July 2021.

This stage introduces efficiency requirements for motors 0.12 to 0.74kW, which must now meet IE2 efficiency levels. Previously the IE3 efficiency requirement stopped at 375kW, this has now been increased to 1000kW.

In addition to the efficiency level changes above, the following motor types are to be introduced in stage one: 8 pole speeds, Brake motors, Hazardous area motors: Ex ec, Ex tb, Ex tc & Ex db. Totally Enclosed Air Overmmotors (IC418) and motors with duty cycles: S1, S3 ≥ 80%, S6 ≥ 80%.

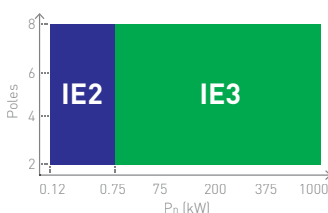

Introduction of IE2 0.12 to 0.74kW
IE3 from 0.75kW to 1000kW

Stage two:

Stage two - 1st July 2023.

IE4 is introduced, this will be mandatory for motor outputs 75kW to 200kW in 2, 4 & 6 poles, but excludes ATEX motors according to 2014/34/EU and brake motors.

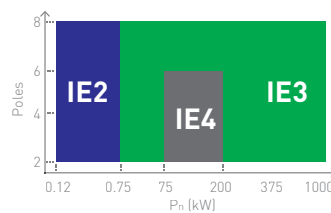

Introduction of IE4 75kW to 200kW

Stage two also introduces a minimum efficiency value of IE2 for single phase motors and Ex eb (increased safety) motors.

As in stage one, the following motors are exempt: High voltage motors, Mining motors and Totally Enclosed Non-Ventilated (IC410) motors.

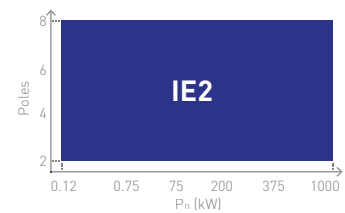

Introduction of Single phase & Ex eb 0.12kW to 1000kW

Please note: IE2 + VSD = IE3 is no longer applicable.

Motors exempt from the new regulation:
High voltage motors, Mining motors and Totally Enclosed Non-Ventilated (IC410) motors.

Performance data

IE2 & IE3

4 2 pole (3000min⁻¹)

P _N kW (hp)	n min ⁻¹	Type	Frame reference and size	IE2	Full load current at rated voltage			η 1.0 P _N 0.75 P _N 0.5 P _N	Cos φ 1.0 P _N 0.75 P _N 0.5 P _N	Power factor	Full load torque	Direct on line starting torque ratio	Direct on line pull up torque ratio	Direct on line pull out torque ratio	Direct on line starting current ratio	Star delta starting torque ratio	Star delta pull up torque ratio	Star delta starting current ratio	Rotor inertia Wk ²	Mean sound pressure level (d 1m on no load)
					230V A	400V A	690V A													
0.12 (0.17)	2805	WU-DA63SF ⁽¹⁾		IE2	0.67	0.39	-	53.6 52.8 48.5	0.84 0.74 0.61		0.41	1.7	1.4	1.1	4.2	-	-	-	0.0005	52
0.18 (0.25)	2770	WU-DA63SG ⁽¹⁾		IE2	0.86	0.50	-	60.4 58.8 53.7	0.87 0.78 0.64		0.62	1.8	1.5	1.2	4.5	-	-	-	0.00063	52
0.25 (0.33)	2715	WU-DA63SG ⁽¹⁾		IE2	1.1	0.63	-	64.8 67.6 66.6	0.88 0.81 0.68		0.88	1.5	1.2	1.1	4.0	-	-	-	0.00063	52
0.37 (0.5)	2860	WU-DA71SK ⁽¹⁾		IE2	1.61	0.93	-	69.5 71.3 69.3	0.88 0.75 0.61		1.24	2.3	2.0	1.9	5.7	-	-	-	0.00063	51
0.55 (0.75)	1460	WU-DA71SK ⁽¹⁾		IE2	2.3	1.32	-	74.1 74.4 71.7	0.81 0.72 0.55		1.84	2.2	1.9	1.9	5.5	-	-	-	0.00063	51
0.75 (1.0)	2890	WP-DA80MM ⁽¹⁾		IE3	2.70	1.55	-	80.7 81.0 77.0	0.86 0.80 0.68		2.48	3.2	2.2	2.3	7.7	-	-	-	0.0013	64
1.1 (1.5)	2885	WP-DA80MS ⁽¹⁾		IE3	3.95	2.30	-	82.7 83.4 81.5	0.84 0.78 0.66		3.64	3.6	3.0	3.1	7.7	-	-	-	0.0012	64
1.5 (2.0)	2880	WP-DA90SMX ⁽¹⁾		IE3	5.25	3.0	-	84.2 84.6 83.2	0.86 0.81 0.70		5.0	3.4	2.7	2.8	8.2	-	-	-	0.0014	64
2.2 (3.0)	2885	WP-DA90LSX ⁽¹⁾		IE3	7.9	4.6	-	85.9 86.2 84.5	0.81 0.73 0.59		7.3	3.8	3.5	3.6	8.6	-	-	-	0.0016	64
3.0 (4.0)	2880	WP-DA100LMF ⁽¹⁾		IE3	9.3	5.3	-	87.1 88.0 87.8	0.93 0.90 0.84		10.0	3.0	2.7	3.3	8.2	-	-	-	0.0058	60
4.0 (5.5)	2895	WP-DA112MR ⁽¹⁾		IE3	-	7.4	4.3	88.1 88.3 87.0	0.89 0.83 0.73		13.2	3.9	2.9	3.0	10	1.2	0.9	3.1	0.0064	60
5.5 (7.5)	2930	WP-DA132SGX ⁽¹⁾		IE3	-	10.7	6.2	89.2 88.6 86.8	0.83 0.76 0.63		17.9	3.9	3.6	4.0	10	1.2	1.1	3.1	0.015	66
7.5 (10)	2930	WP-DA132SMX ⁽¹⁾		IE3	-	13.8	8.0	90.1 89.9 88.4	0.87 0.81 0.70		24.4	3.6	3.3	3.8	9.6	1.1	1.0	3.0	0.018	66
11 (15)	2945	WP-DA160MJ ⁽¹⁾		IE3	-	19.8	11.5	91.2 91.0 89.7	0.88 0.85 0.77		35.7	2.5	2.2	2.9	8.3	0.8	0.7	2.6	0.045	68
15 (20)	2940	WP-DA160MR ⁽¹⁾		IE3	-	26.2	15.2	91.9 91.7 90.0	0.90 0.87 0.79		48.7	2.4	2.1	2.5	8.2	0.8	0.7	2.6	0.056	68
18.5 (25)	2955	WP-DA160LT ⁽¹⁾		IE3	-	32.8	19.0	92.4 92.4 91.0	0.88 0.84 0.75		59.8	2.6	2.3	3.1	9.1	0.8	0.7	2.8	0.063	68
22 (30)	2950	WP-DA180MF ⁽¹⁾		IE3	-	38.5	22.3	92.7 93.0 92.7	0.89 0.85 0.77		71.2	2.3	2.0	3.1	9.0	0.7	0.6	2.8	0.089	68

⁽¹⁾ European & BS frame reference.

Performance data

IE2 & IE3

5

4 pole (1500min⁻¹)

P _N kW (hp)	n min ⁻¹	Type	IE2	I _N			η		Cos φ		M _N Nm	M _A M _N	M _S M _N	M _R M _N	I _A I _N	M _A M _N Y	M _S M _N Y	I _A I _N Y	J kgm ²	L _{PA} dB(A)
				230V A	400V A	690V A	1.0 P _N 0.75 P _N	0.75 P _N 0.5 P _N	1.0 P _N 0.75 P _N	0.75 P _N 0.5 P _N										
0.12 (0.17)	1410	WU-DA63SG ⁽¹⁾	IE2	0.76	0.44	-	59.1 57.1 51.1	0.67 0.57 0.44		0.8	2.2	1.9	2.5	4.0	-	-	-	0.00063	39	
0.18 (0.25)	1395	WU-DA63SK ⁽¹⁾	IE2	0.94	0.54	-	64.7 64.8 59.1	0.74 0.63 0.49		1.2	2.2	1.9	2.5	3.9	-	-	-	0.0008	39	
0.25 (0.33)	1410	WU-DA71SK ⁽¹⁾	IE2	1.39	0.80	-	68.5 66.8 61.3	0.66 0.56 0.44		1.7	2.3	2.0	2.3	4.9	-	-	-	0.00087	38	
0.37 (0.50)	1395	WU-DA71SR ⁽¹⁾	IE2	1.73	0.99	-	72.7 73.2 70.2	0.74 0.65 0.51		2.5	2.1	1.8	2.4	7.5	-	-	-	0.0011	38	
0.55 (0.75)	1435	WU-DA80MS ⁽¹⁾	IE2	2.63	1.51	-	77.1 76.2 72.5	0.68 0.58 0.45		3.7	4.0	3.7	4.3	6.5	-	-	-	0.0028	47	
0.75 (1.0)	1420	WP-DA80MS ⁽¹⁾	IE3	3.20	1.85	-	82.5 82.0 79.5	0.71 0.62 0.47		5.04	3.2	2.9	3.2	6.2	-	-	-	0.0028	47	
1.1 (1.5)	1430	WP-DA90LTX ⁽¹⁾	IE3	4.3	2.5	-	84.1 84.4 84.0	0.77 0.70 0.57		7.3	2.1	1.8	2.2	6.2	-	-	-	0.0037	48	
1.5 (2.0)	1440	WP-DA90LWX ⁽¹⁾	IE3	6.3	3.6	-	85.3 85.1 83.5	0.70 0.60 0.48		10.0	3.6	3.3	3.6	7.4	-	-	-	0.0042	48	
2.2 (3.0)	1450	WP-DA100LRF ⁽¹⁾	IE3	8.1	4.6	-	86.7 87.0 86.0	0.79 0.70 0.57		14.5	3.2	2.9	3.3	7.3	-	-	-	0.0106	54	
3.0 (4.0)	1460	WP-DA100LTF ⁽¹⁾	IE3	11.6	6.7	-	87.7 87.3 85.4	0.74 0.63 0.50		19.6	3.7	3.4	3.8	8.1	-	-	-	0.0121	54	
4.0 (5.5)	1450	WP-DA112MWX ⁽¹⁾	IE3	-	8.4	4.8	88.6 88.6 88.0	0.78 0.70 0.56		26.3	3.5	3.2	3.5	8.0	1.1	1.0	2.5	0.0151	54	
5.5 (7.5)	1460	WP-DA132STX ⁽¹⁾	IE3	-	10.9	6.3	89.6 90.0 88.7	0.81 0.73 0.60		36.0	3.3	3.0	3.9	8.7	1.0	0.9	2.7	0.03	59	
7.5 (10)	1450	WP-DA132MVX ⁽¹⁾	IE3	-	14.6	8.5	90.4 90.4 90.2	0.82 0.76 0.67		49.4	2.8	2.5	3.0	7.6	0.9	0.8	2.4	0.033	59	
11 (15)	1475	WP-DA160MR ⁽¹⁾	IE3	-	21.2	12.3	91.4 91.4 90.6	0.82 0.76 0.67		71.2	2.5	2.2	2.7	9.0	0.8	0.7	2.8	0.084	63	
15 (20)	1475	WP-DA160LU ⁽¹⁾	IE3	-	28.3	16.4	92.1 92.0 91.0	0.83 0.76 0.67		97.1	2.5	2.2	2.8	8.2	0.8	0.7	2.6	0.098	63	
18.5 (25)	1475	WP-DA180MJ ⁽¹⁾	IE3	-	34.3	19.9	92.6 92.8 92.0	0.84 0.79 0.69		120	2.4	2.1	2.6	7.5	0.8	0.7	2.3	0.19	62	
22 (30)	1470	WP-DA180LM ⁽¹⁾	IE3	-	41.1	23.8	93.0 93.0 91.5	0.83 0.78 0.67		143	2.4	2.1	2.6	8.8	0.8	0.7	2.8	0.22	62	

⁽¹⁾ European & BS frame reference.

Rated power
Full load speed in
revolutions per minute
and size
Frame reference

Full load current at
rated voltage

Efficiency

Power factor

Full load torque
Direct on line
starting torque ratio
Direct on line
pull up torque ratio
Direct on line
pull out torque ratio
Direct on line
starting current ratio
Star delta
starting torque ratio
Star delta
pull up torque ratio
Star delta
starting current ratio
Rotor inertia Wk²
Mean sound pressure
level (d 1m on no load)

Performance data

IE2 & IE3

6 6 pole (1000min⁻¹)

P _N kW (hp)	n min ⁻¹	Type	IE2/IE3	Full load current at rated voltage			η 0.75 P _N 0.5 P _N	Cos φ 1.0 P _N 0.75 P _N 0.5 P _N	M _N Nm	M _Δ M _N	M _S M _N	M _R M _N	I _A I _N	M _Δ M _N Y	M _S M _N Y	I _A I _N Y	J kgm ²	L _{PA} dB(A)
				230V A	400V A	690V A												
0.12 (0.17)	905	WU-DA71SK ⁽¹⁾	IE2	0.92	0.53	-	{ 50.6 0.65 48.7 0.55 42.7 0.44 }	1.27	1.6	1.4	1.8	3.0	-	-	-	0.00097	44	
0.18 (0.25)	905	WU-DA71SR ⁽¹⁾	IE2	1.35	0.78	-	{ 56.6 0.59 54.5 0.50 48.5 0.40 }	1.9	1.8	1.6	2.0	3.0	-	-	-	0.00124	44	
0.25 (0.33)	905	WU-DA71SR ⁽¹⁾	IE2	1.80	1.10	-	{ 61.6 0.56 61.0 0.47 55.2 0.37 }	2.6	1.7	1.5	1.9	3.0	-	-	-	0.00124	44	
0.37 (0.5)	925	WU-DA80MM ⁽¹⁾	IE2	2.29	1.31	-	{ 67.6 0.60 66.0 0.51 60.4 0.39 }	3.8	2.4	2.1	2.6	3.7	-	-	-	0.0021	49	
0.55 (0.75)	930	WU-DA90LT ^{^ (1)}	IE2	2.90	1.67	-	{ 73.1 0.65 72.9 0.56 69.4 0.43 }	5.6	2.5	2.2	2.7	4.5	-	-	-	0.0039	65	
0.75 (1.0)	935	WP-DA90LWX ⁽¹⁾	IE3	3.7	2.1	-	{ 78.9 0.64 78.5 0.56 76.0 0.44 }	7.7	2.9	2.6	3.1	4.6	-	-	-	0.0042	65	
1.1 (1.5)	-	TBA	IE3	-	-	-	{ - - - - - - }	-	-	-	-	-	-	-	-	-	-	
1.5 (2.0)	970	WP-DA100LTF ⁽¹⁾	IE3	7.6	4.4	-	{ 82.5 0.60 82.1 0.51 78.9 0.40 }	14.8	3.5	3.2	4.1	6.2	-	-	-	0.012	58	
2.2 (3.0)	960	WP-DA112MWX ⁽¹⁾	IE3	10.1	5.8	-	{ 84.3 0.65 84.4 0.58 81.8 0.43 }	21.9	2.8	2.5	3.0	5.6	-	-	-	0.015	54	
3.0 (4.0)	970	WP-DA132SMX ⁽¹⁾	IE3	12.7	7.3	-	{ 85.6 0.69 85.7 0.62 82.0 0.43 }	29.5	2.3	2.0	2.5	6.1	-	-	-	0.032	58	
4.0 (5.5)	960	WP-DA132MTX ⁽¹⁾	IE3	-	9.8	5.8	{ 86.8 0.68 86.5 0.59 83.3 0.49 }	39.8	2.3	2.0	2.5	5.5	0.7	0.6	1.7	0.038	58	
5.5 (7.5)	965	WP-DA132MVX ⁽¹⁾	IE3	-	13.3	7.7	{ 88.0 0.68 87.0 0.53 84.0 0.42 }	54.5	2.6	2.3	3.0	6.5	0.8	0.7	2.0	0.041	58	
7.5 (10)	975	WP-DA160MM ⁽¹⁾	IE3	-	16.6	9.6	{ 89.1 0.73 89.3 0.65 88.9 0.56 }	73.5	1.7	1.5	1.6	5.1	0.5	0.5	1.6	0.10	59	
11 (15)	980	WP-DA160LV ⁽¹⁾	IE3	-	23.4	13.6	{ 90.3 0.75 90.3 0.67 88.5 0.56 }	107	2.0	1.7	2.5	5.7	0.6	0.5	1.8	0.12	59	
15 (20)	980	WP-DA180LM ⁽¹⁾	IE3	-	30.4	17.6	{ 91.2 0.78 91.5 0.72 89.9 0.61 }	146	2.0	1.7	2.4	6.0	0.6	0.5	1.9	0.24	59	

⁽¹⁾ European & BS frame reference. ^ Up a frame size

Performance data

IE2 & IE3

7

8 pole (750min⁻¹)

P _N kW (hp)	n min ⁻¹	Type	IE2/IE3	Full load current at rated voltage			Efficiency		Power factor	Full load torque	Direct on line starting torque ratio	Direct on line pull up torque ratio	Direct on line pull out torque ratio	Direct on line starting current ratio	Star delta starting torque ratio	Star delta pull up torque ratio	Star delta starting current ratio	Rotor inertia Wkg ²	Mean sound pressure level (d 1m on no load)
				230V A	400V A	690V A	1.0 P _N 0.75 P _N 0.5 P _N	1.0 P _N 0.75 P _N 0.5 P _N											
0.18 (0.25)	665	WU-DA80MG ⁽¹⁾	IE2	1.73	0.99	-	{ 45.9 42.0 34.8 }	{ 0.57 0.49 0.40 }	2.6	2.1	1.9	2.0	2.6	-	-	-	0.0017	46	
0.25 (0.33)	665	WU-DA80MM ⁽¹⁾	IE2	2.18	1.25	-	{ 50.6 47.0 39.7 }	{ 0.57 0.48 0.39 }	3.6	2.1	1.9	2.0	2.7	-	-	-	0.0021	46	
0.37 (0.5)	680	WU-DA90SM ⁽¹⁾	IE2	2.71	1.56	-	{ 56.1 54.2 48.4 }	{ 0.61 0.51 0.40 }	5.2	2.0	1.8	2.0	2.8	-	-	-	0.0035	50	
0.55 (0.75)	685	WU-DA90LS ⁽¹⁾	IE2	3.93	2.26	-	{ 61.7 59.2 52.5 }	{ 0.57 0.47 0.37 }	7.7	2.4	2.2	2.4	3.0	-	-	-	0.0040	50	
0.75 (1.0)	-	TBA	IE3	-	-	-	{ - - - }	{ - - - }	-	-	-	-	-	-	-	-	-	-	
1.1 (1.5)	-	TBA	IE3	-	-	-	{ - - - }	{ - - - }	-	-	-	-	-	-	-	-	-	-	
1.5 (2.0)	-	TBA	IE3	-	-	-	{ - - - }	{ - - - }	-	-	-	-	-	-	-	-	-	-	
2.2 (3.0)	725	WP-DA132STX ⁽¹⁾	IE3	11.6	6.7	-	{ 81.9 81.0 77.7 }	{ 0.58 0.49 0.37 }	29	2.2	1.9	2.5	4.8	-	-	-	0.035	57	
3.0 (4.0)	715	WP-DA132MVX ⁽¹⁾	IE3	14.3	8.2	-	{ 83.5 83.6 81.4 }	{ 0.63 0.54 0.42 }	40.1	1.8	1.6	2.0	4.6	-	-	-	0.041	57	
4.0 (5.5)	725	WP-DA160MM ⁽¹⁾	IE3	-	9.9	5.7	{ 84.8 84.9 83.3 }	{ 0.69 0.61 0.49 }	52.7	1.5	1.3	1.7	4.8	-	-	-	0.11	53	
5.5 (7.5)	730	WP-DA160MV ⁽¹⁾	IE3	-	13.7	8.0	{ 86.2 85.9 83.9 }	{ 0.67 0.59 0.46 }	72	1.9	1.7	2.4	5.3	-	-	-	0.14	53	
7.5 (10)	730	WP-DA160LX ⁽¹⁾	IE3	-	18.2	10.6	{ 87.3 87.2 85.5 }	{ 0.68 0.60 0.47 }	98.1	1.9	1.7	2.3	5.3	0.6	0.5	1.7	0.186	53	
11 (15)	730	WP-DA180LR ⁽¹⁾	IE3	-	27.2	15.7	{ 88.6 88.4 86.9 }	{ 0.66 0.58 0.46 }	144	1.9	1.7	2.3	5.1	0.6	0.5	1.6	0.247	58	

⁽¹⁾ European & BS frame reference.

Dimensions - IEC & BS specifications

8

Foot, flange and face mounting
Frame sizes 63 to 180 aluminium

IM B3
IM 1001
Mounting options

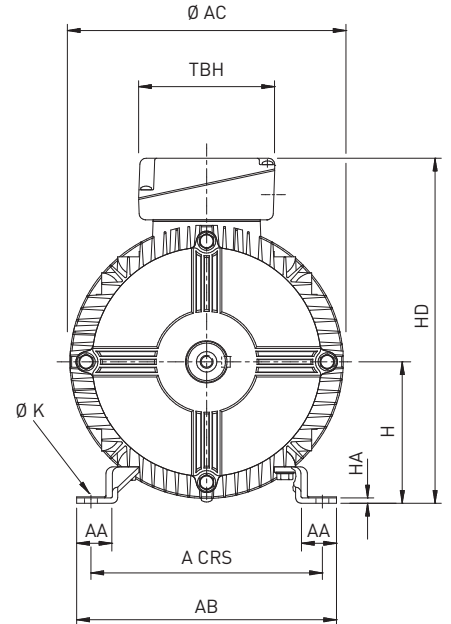
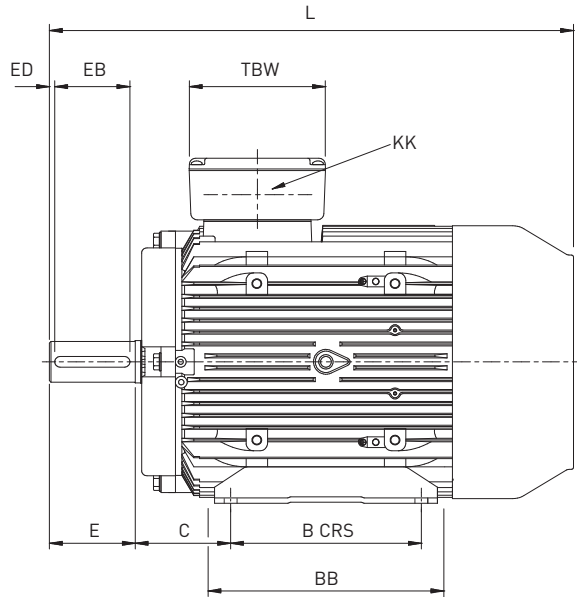

IM B5 / IM B35
IM 3001 / IM 2001
Mounting options

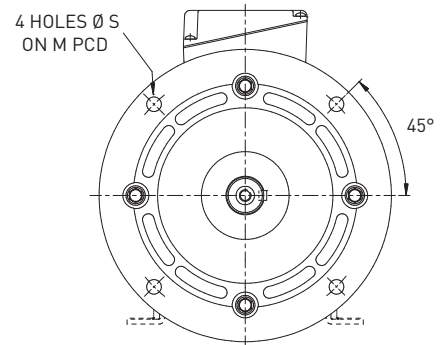
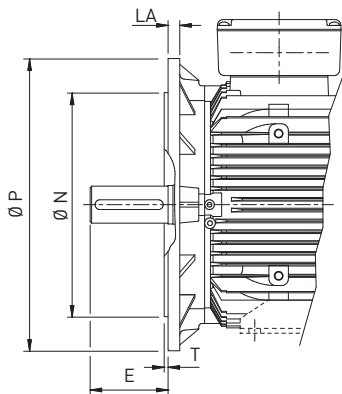

IM B5 / IM B35
IM 3001 / IM 2001
Mounting options

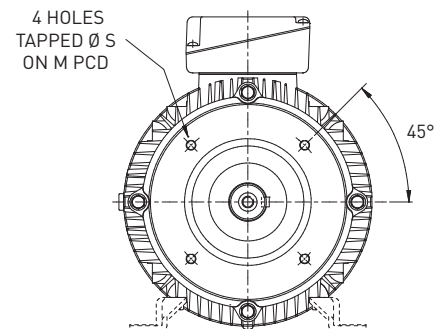
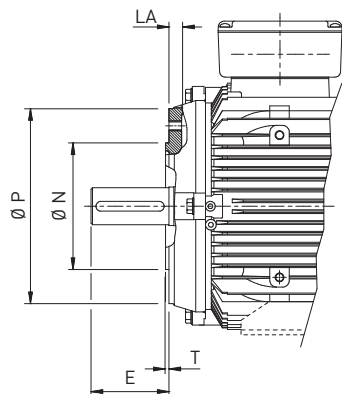

Dimensions - IEC & BS specifications

Foot, flange and face mounting
Frame sizes 63 to 180 aluminium

General Dimensions

Type	A	B	C	H	K	L	AA	AB	∅ AC	BB	HA	HD	TBW	TBH	KK
WU-DA63S	100	80	40	63	7	207	19	119	126	100	2	163	86	86	1 x CM20
WU-DA71S	112	90	45	71	7	238	19	131	140	110	2	186	86	86	1 x CM20
WP/U-DA80M	125	100	50	80	10	278	27	157	160	127	4	212	86	86	1 x CM20
WU-DA90S	140	100	56	90	10	322	28	164	178	150	4	225	86	86	1 x CM20
WU-DA90L	140	125	56	90	10	322	28	164	178	150	4	225	86	86	1 x CM20
WP-DA90SX	140	100	56	90	10	349	28	164	178	150	4	225	86	86	1 x CM20
WP-DA90LX	140	125	56	90	10	349	28	164	178	150	4	225	86	86	1 x CM20
WP-DA100L	160	140	63	100	12	368	28	184	199	170	4	254	106	106	2 x CM20
WP-DA100LF	160	140	63	100	12	442	28	184	199	170	4	254	127	127	2 x CM20
WP-DA112M	190	140	70	112	12	382	40	218	215	170	4	279	127	127	2 x CM25
WP-DA112MX	190	140	70	112	12	442	40	218	199	170	4	279	127	127	2 x CM25
WP-DA132SX	216	140	89	132	12	489	47	242	256	208	5	323	127	127	2 x CM25
WP-DA132MX	216	178	89	132	12	489	47	242	256	208	5	323	127	127	2 x CM25
WP-DA160M	254	210	108	160	15	605	55	304	315	304	5	400	140	140	2 x CM32
WP-DA160L	254	254	108	160	15	605	55	304	315	304	5	400	140	140	2 x CM32
WP-DA180M	279	241	121	180	15	667	64	329	358	329	6	440	140	140	2 x CM32
WP-DA180L	279	279	121	180	15	667	64	329	358	329	6	440	140	140	2 x CM32

D Flange

Type	IM B5 flange mounting					
	M	N	P	S	T	LA
WU-DA63	115	95	140	10	3	7
WU-DA71	130	110	160	10	3.5	7
WP/U-DA80	165	130	200	12	3.5	12
WP/U-DA90	165	130	200	12	3.5	12
WP-DA100	215	180	250	15	4	12
WP-DA112	215	180	250	15	4	12
WP-DA132	265	230	300	15	4	12
WP-DA160	300	250	350	19	5	13
WP-DA180	300	250	350	19	5	15

For flange spigot tolerance details 'N', see page 15

C Face

Type	IM B14 flange mounting					
	M	N	P	S	T	LA
WU-DA63	75	60	90	M5	2.5	7
WU-DA71	85	70	105	M6	2.5	9
WP/U-DA80	100	80	120	M6	3	9
WP/U-DA90	115	95	140	M8	3	9
WP-DA100	130	110	160	M8	3.5	12.5
WP-DA112	130	110	164	M8	3.5	13
WP-DA132	165	130	200	M10	3.5	14
WP-DA160	215	180	250	M12	4	13
WP-DA180	-	-	-	-	-	-

Note, care must be taken to ensure mounting bolts do not protrude beyond the 'C' face casting thickness 'LA'

For face spigot tolerance details 'N', see page 15

Shaft

Type	All poles							
	∅ D	E	F	G	GD	EB	ED	DH
WU-DA63	11	23	4	8.5	4	10	0	M4 x 10
WU-DA71	14	30	5	11	5	20	5	M5 x 12.5
WP/U-DA80	19	40	6	15.5	6	32	4	M6 x 16
WP/U-DA90	24	50	8	20	7	40	5	M8 x 19
WP-DA100	28	60	8	24	7	50	5	M10 x 22
WP-DA112	28	60	8	24	7	50	5	M10 x 22
WP-DA132	38	80	10	33	8	70	5	M12 x 28
WP-DA160	42	110	12	37	8	100	5	M16 x 36
WP-DA180	48	110	14	42.5	9	100	5	M16 x 36

For shaft tolerance details, see page 15

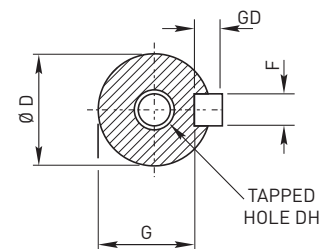

Shaft dimensions

Dimensions

10

Pad / Rod mounting
Frame sizes 63 to 180 aluminium

IM B30
IM 9201
Mounting options

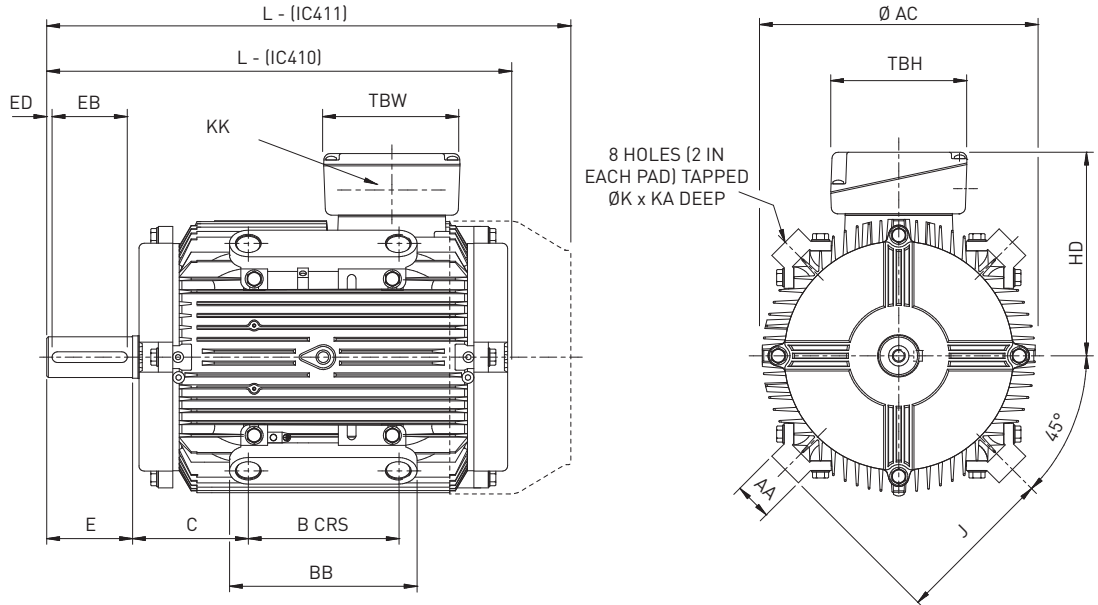

General Dimensions - Pad / Rod

Type	B	C	J	K	KA	L ^{IC410}	L ^{IC411}	AA	Ø AC	BB	HD	TBW	TBH	KK
WU-DA63S	90	45	70	M8	12	180	207	18	126	119	100	86	86	1 x CM20
WU-DA71S	90	45	83.5	M8	12	204	238	17	140	107	115	86	86	1 x CM20
WP/U-DA80M	90	55	95	M12	14	253	278	23	160	113	132	86	86	1 x CM20
WU-DA90L	90	73.5	103	M12	13	299	322	24	178	114	135	86	86	1 x CM20
WP-DA90LX	90	73.5	103	M12	13	326	349	24	178	114	135	86	86	1 x CM20
WP-DA100L	100	83	112.5	M12	15	322	409	24	199	124	154	106	106	2 x CM20
WP-DA100LF	100	90 [^]	125	M12	15	396	442	24	199	124	167	127	127	2 x CM20
WP-DA112M	100	90	125	M12	18	336	382	24	215	124	167	127	127	2 x CM25
WP-DA112MX	100	90	125	M12	15	396	442	24	199	124	167	127	127	2 x CM25
WP-DA132MX	140	108	150	M16	19	430	485	35	256	175	188	127	127	2 x CM25
WP-DA160L	200	135	181	M20	22	533	604	35	315	245	240	140	140	2 x CM32
WP-DA180L	200	160.5	202	M20	22	590	663	35	358	235	260	140	140	2 x CM32

[^] non standard dimension
63 frame pad / road mounting is not available with a terminal box.

Shaft

Type	All poles							
	Ø D	E	F	G	GD	EB	ED	DH
WU-DA63	11	23	4	8.5	4	10	0	M4 x 10
WU-DA71	14	30	5	11	5	20	5	M5 x 12.5
WP/U-DA80	19	40	6	15.5	6	32	4	M6 x 16
WP/U-DA90	24	50	8	20	7	40	5	M8 x 19
WP-DA100	28	60	8	24	7	50	5	M10 x 22
WP-DA112	28	60	8	24	7	50	5	M10 x 22
WP-DA132	38	80	10	33	8	70	5	M12 x 28
WP-DA160	42	110	12	37	8	100	5	M16 x 36
WP-DA180	48	110	14	42.5	9	100	5	M16 x 36

For shaft tolerance details, see page 15

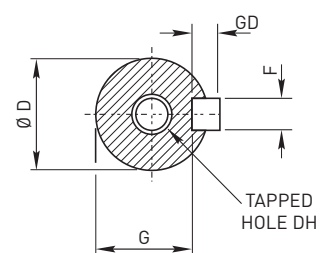

Shaft dimensions

Drip Proof Canopy & Mounting options

Drip proof canopy (impact canopy)

A drip proof canopy (impact canopy) can be fitted to the W aluminium range.

To find the overall length of a motor fitted with a drip proof canopy, please add dimension 'DPC' to dimension 'L'.

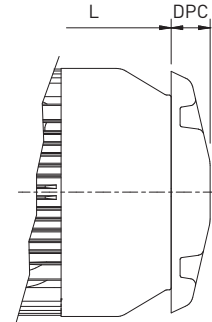

Type	L + DPC
63 to 90	'L' + 29mm
100 to 112	'L' + 30mm
132 to 180	'L' + 40mm

Mounting options

Horizontal shaft:

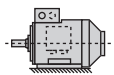

IM B3
IM 1001
foot mounted

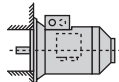

IM B5
IM 3001
flange at DE
no feet



IM B6
IM 1051
foot wall mounted with
feet on left-hand side
when viewed from DE



IM B7
IM 1061
foot wall mounted with
feet on right-hand side
when viewed from DE



IM B8
IM 1071
ceiling mounted
with feet
above motor

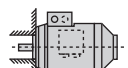

IM B14
IM 3601
face at DE
no feet

Vertical shaft:

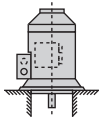

IM V1
IM 3011
flange at DE
shaft down
no feet

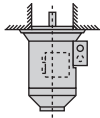

IM V3
IM 3031
flange at DE
shaft up
no feet

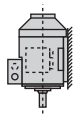

IM V5
IM 1011
vertical foot
wall mounted
shaft down

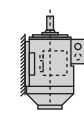

IM V6
IM 1031
vertical foot
wall mounted
shaft up

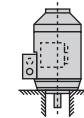

IM V18
IM 3611
face at DE
shaft down
no feet

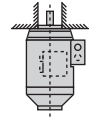

IM V19
IM 3631
face at DE
shaft up
no feet

Combinations of the above are possible. e.g. B3/B5 or B35 (IM2001), B3/B14 or B34 (IM2101).
B14, V18 & V19 available upto and including the 160 frame.
B30 pad / rod mounting option available (not shown above).

Mechanical: Axial and radial loads frames 63 to 180

Maximum permissible external axial thrust and radial loads in Newtons (N)								
Type	Poles	Horizontal shaft		Vertical shaft				Maximum permissible radial load at end of shaft (standard mounting)
		Load towards motor	Load away from motor	Shaft up		Shaft down		
				Load towards motor	Load away from motor	Load towards motor	Load away from motor	
WU-DA63	2	324	480	316	491	335	472	434
	4	253	409	245	420	264	401	372
WU-DA71	2	236	392	227	405	249	383	340
	4	207	363	196	380	224	352	314
	6	189	345	174	362	206	330	292
WP/U-DA80	2	339	539	321	565	362	521	774
	4	303	503	283	530	330	583	729
	6	284	484	260	516	316	460	646
WP/U-DA90	8	296	496	272	528	328	472	662
	2	444	684	421	716	476	661	915
	4	398	638	366	682	442	606	854
	6	349	589	309	641	401	549	720
WP-DA100	8	369	609	334	656	416	574	747
	2	781	1101	743	1159	839	1063	1295
	4	710	1030	655	1107	787	975	1215
	6	560	880	506	963	643	826	1145
WP-DA112	8	580	900	521	985	665	841	1018
	2	768	1088	715	1170	850	1035	1295
	4	690	1010	612	1131	811	932	1202
WP-DA132	6	541	861	463	979	659	783	1141
	8	565	885	487	1003	683	807	1009
	2	1355	1707	1266	1838	1486	1618	1614
	4	1253	1605	1130	1779	1427	1482	2068
WP-DA160	6	1167	1519	1035	1711	1359	1387	1968
	8	997	1349	858	1556	1204	1210	1600
	2	2144	2639	1951	2920	2425	2446	3613
	4	2123	2618	1895	2959	2464	2390	3738
WP-DA180	6	1973	2468	1669	2905	2410	2164	3544
	8	1464	1959	1144	2358	1863	1639	3233
	2	2711	3274	2465	3667	3104	3027	4374
	4	2749	3312	2426	3801	3238	2988	4556
WP-DA180	6	2575	3138	2166	3785	3222	2728	4334
	8	1464	1959	2435	1144	1940	1344	3233

All figures are based on L10aah life of 20,000 hours

Typical speed / torque curve

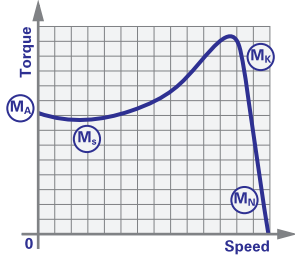

(M_A) - Starting torque or locked rotor torque
 (M_B) - Pull up torque or run up torque
 (M_C) - Pull out torque or breakdown torque
 (M_N) - Full load torque

Typical speed / current curve

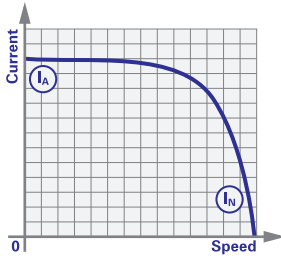

(I_A) - Starting current
 (I_N) - Full load current

Notes

With Star-Delta starting, during the run up period in Star, there must be an adequate excess of motor torque over the load torque. The change to Delta must not occur until the motor is near the operating speed.

Refer to Brook Crompton for running up against a load in excess of 70% full load during Star Delta starting.

Motors are wound for either 230 / 400 volts or 400 / 690 volts

Performance figures are subject to EN tolerances.

Performance figures are based on a 400 volt winding.

Performance data within this catalogue, is from motor testing in accordance with EN 60034-2-1.

J Rotor Inertia

$$J \text{ (WK}^2 \text{ or WR}^2) = \frac{GD^2}{4}$$

$$J \text{ in lb ft}^2 : \frac{\text{kgm}^2}{0.042}$$

Environmental conditions

High ambient temperatures and High Altitudes

The kW ratings listed in this catalogue apply to standard motors operating in ambient temperatures not exceeding 40°C and altitudes up to 1000m above sea level.

When operating a standard motor in higher ambient temperatures or at higher altitudes, derating may be necessary in order to maintain its operating temperature limit.

The listed factors in the table to the right should be used for derating.

Eup Efficiency Levels

Motors working from -30°C to +60°C and up to 4000m above sea level, efficiencies must be in-line with the legislated ErP efficiency levels.

Derating factor for high ambient temperatures	Ambient temperature			
	45°C	50°C	55°C	60°C
Class B temperature limits	0.96	0.93	0.87	0.83
Class F temperature limits	1.0	1.0	1.0	0.95

Derating factor for altitude	Altitude			
	1000m	2000m	3000m	4000m
Class B temperature limits	1.0	0.94	0.85	0.75
Class F temperature limits	1.0	1.0	1.0	0.95

Dimension page notes

Shaft and Flange spigot tolerances

Shaft		
Dim \varnothing D	Tol.	Limits
11 to 14	j6	+0.008 -0.003
19 to 28	j6	+0.009 -0.004
38 to 48	k6	+0.018 +0.002

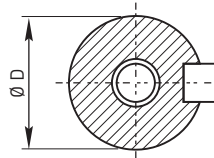

All dimensions shown are in millimetres

Dimensions should not be used for installation purposes unless specially endorsed

B5 D Flange mounted motors have suffix '-D' in the frame reference, eg WP-DA112MVX-D.

B35 Foot & D Flange mounted motors have suffix '-H' in the frame reference, eg WP-DA112MVX-H

B14 C face mounted motors have suffix 'C' in the frame reference, eg WP-DA112MVX-C and

B34 Foot & C Face mounted motors have suffix '-H' in the frame reference, eg WP-DA112MVX-H

D Flange		
Dim \varnothing N	Tol.	Limits
95 & 110	j6	+0.013 -0.009
130 & 180	j6	+0.014 -0.011
230 & 250	j6	+0.016 -0.013
300	j6	+0.016 -0.016

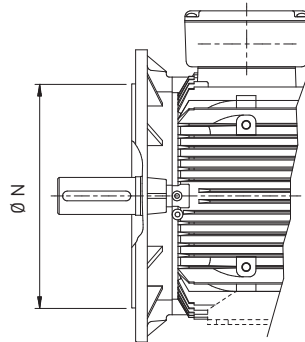

C Face		
Dim \varnothing N	Tol.	Limits
60 to 80	j6	+0.012 -0.007
95 & 110	j6	+0.013 -0.009
130 & 180	j6	+0.014 -0.011

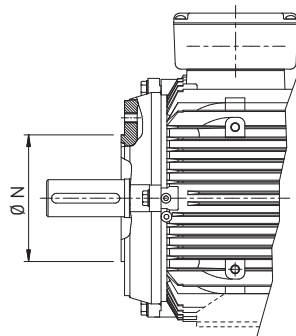

Europe

Brook Crompton UK Ltd

St Thomas' Road Huddersfield
West Yorkshire HD1 3LJ UK
T: +44 (0) 1484 557200
F: +44 (0) 1484 557201
E: sales@brookcrompton.com
www.brookcrompton.com

Brook Crompton UK LTD - Sede secondaria in Italia

Via De Chirico, 9/11
42124 – Reggio Emilia (RE)
T: +39 0522 345055
E: italy@brookcrompton.com
www.brookcrompton.com

Asia

Brook Crompton Asia Pacific Pte Ltd

19 Keppel Road #08-01, Jit Poh Building
Singapore 089058
T: +65 6227 0308
F: +65 6227 0605
E: marketing@brookcrompton-ap.com
www.brookcrompton.com

Brook Crompton Australia Pty Ltd

5/220 New Cleveland Road,
Tingalpa, Queensland
Australia
T: +61 413 431 978
E: australia@brookcrompton.com
www.brookcrompton.com

Americas

Brook Crompton Inc

1100 E. 222nd Street
Euclid, Ohio 44117, USA
T: +1 800 668 6779
T: +1 - 800 463 8917
E: sales@brookcromptonna.com
www.brookcromptonna.com

Brook Crompton Ltd

264 Attwell Drive
Toronto, Ontario, M9W 5B2, Canada
T: + 416 675 3844 (Toronto)
T: +1 888 668 9843 (Quebec)
E: sales@brookcromptonna.com
www.brookcromptonna.com

Every care has been taken to ensure the accuracy of the information contained in this publication, but, due to a policy of continuous development and improvement the right is reserved to supply products which may differ slightly from those illustrated and described in this publication