

Keeping Industry Turning

WEX3 IE3 Zone 1 Flameproof motors

Frame size 80 - 315



**BROOK
CROMPTON** 
Keeping Industry Turning

2406

WOLONG
Power your future

WEX3 Specification

Specification	Standard product	Option
Frame sizes	80 - 315	-
Poles	2-8P	-
Power	0.37kW - 200kW	-
Ex Protection	Ex db IIB T4 Gb	Ex db IIC T4 Gb, Exdb eb IIB / IIC T4 Gb Ex tb IIIB / IIIC T130°C Db
Enclosure	IP55	IP56, IP65, IP66
Mounting option	Foot (B3), Flange (B5), Face (B14), Flange (V1), etc	Foot & Flange (B35), Foot & Face (B34), etc
Terminal box position	80 - 280: Top 315: Top	Right hand side, left hand side (from stock) Right hand side, left hand side (built to order)
Voltage	3 kW and below: 230 / 400 4 kW and above: 400 / 690	on request
Frequency	50 Hz	60 Hz
Cooling	IC411	-
Bearing location	Drive end	Non drive end
Lubrication	80 - 180 double-shielded bearings 200 - 315 regreasing facility	160 - 180 Regreasing facility -
Insulation	class F	class H
Temperature rise	class B	class B
Paint colour	water blue (RAL 5021) , Fan cover (RAL 9005)	on request
Paint Specification (equivalent to IEC 12944)	C3	C4, C5 or Cx
Thermal protection	80 - 315 (by thermistors)	RTDs 160 to 355
Anti-condensation heaters	80 - 132 single voltage 110V 160 - 315 dual voltage 110 / 230V	230V -
Inverter Duty (with derate)	Variable Torque: 10:1 Constant Torque: 2:1, 3:1, 4:1, 5:1, 10:1 Constant Power: 1:1.5 (50 - 75Hz)	Variable speed Variable speed -
Ambient temperature	-20°C to + 40°C	-40°C to +60°C

The above specification and options give a brief summary of features available for the WEX3 flameproof range. For a full listing of optional features, please contact Brook Crompton sales.

WEX3 Configuration

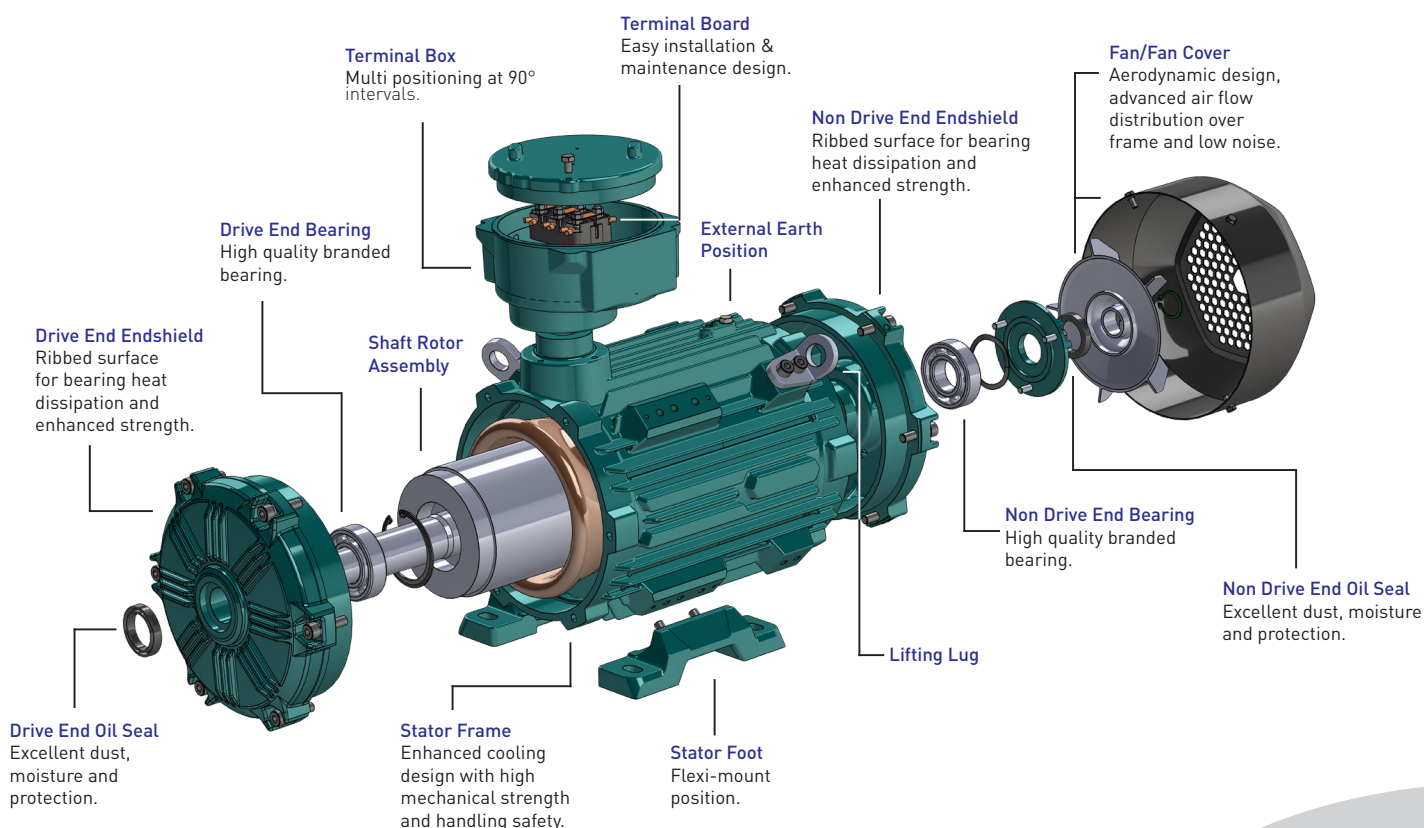

WEX3 Flexible Feet

Images below show the flexibility of the WEX3 range. Other mounting options are available. The C face as fitted to B14 & B34 mounted motors is available up to and including the 112 frame.

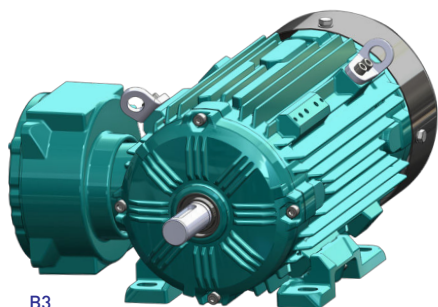

B3 [Terminal box left]

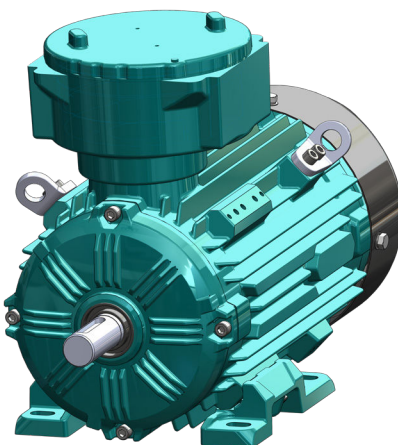

B3

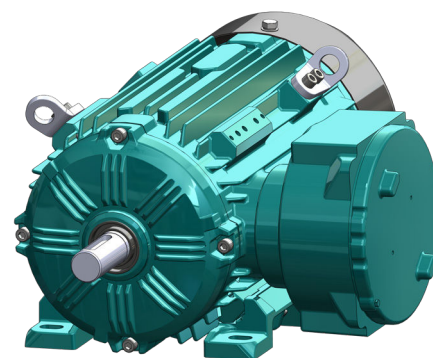

B3 [Terminal box right]

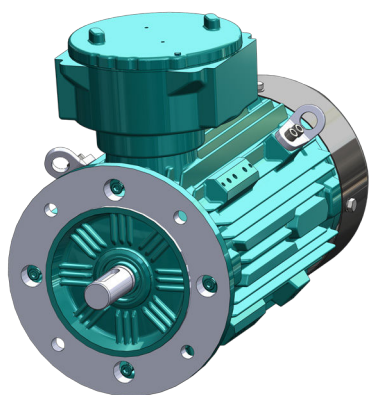

B5

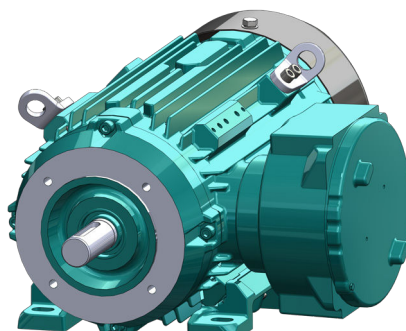

B34 [Terminal box right]

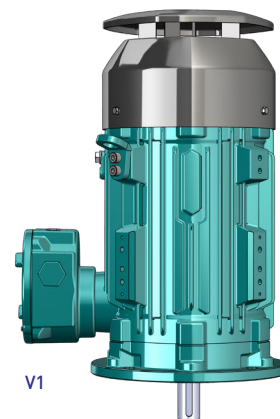

V1

Ex- Explosion Protection

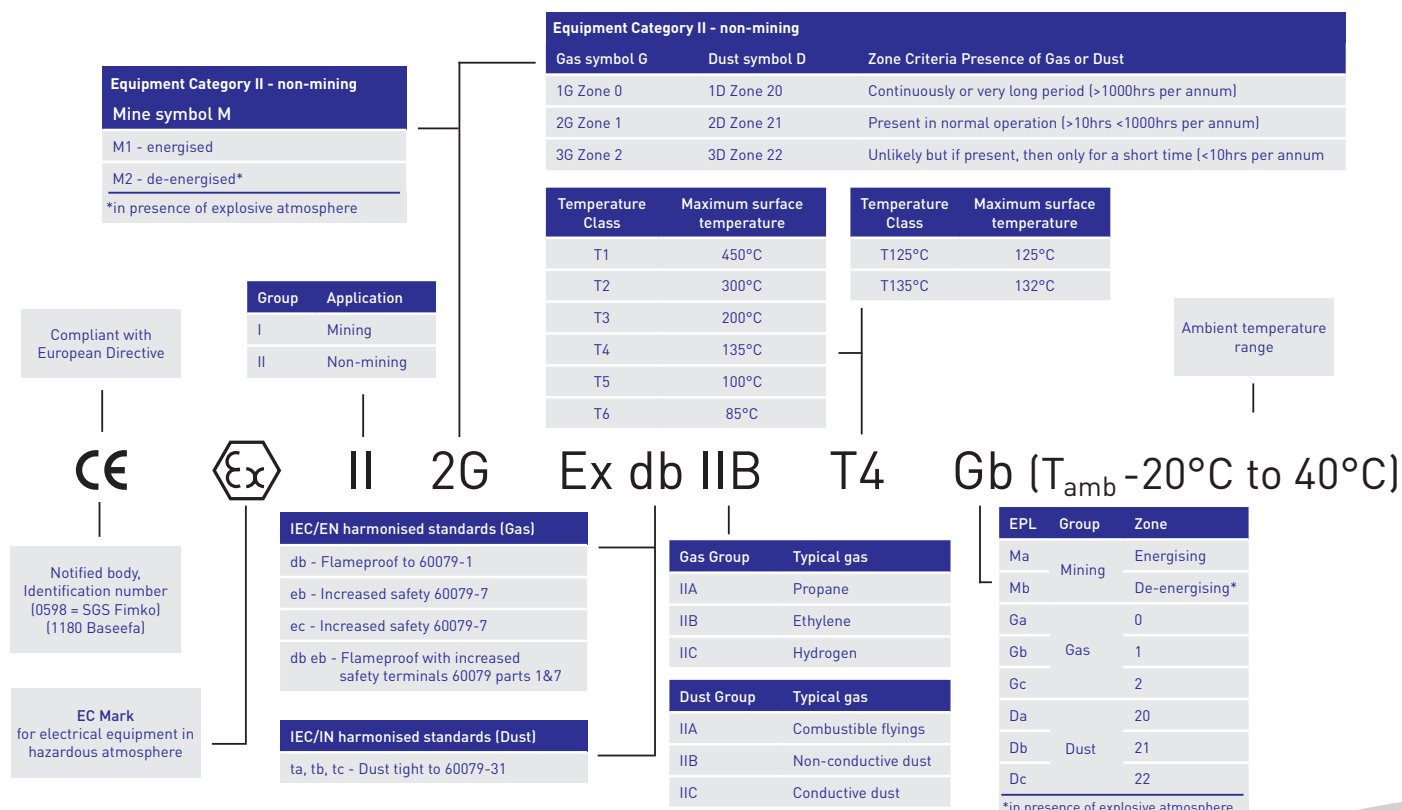

**BROOK
CROMPTON** 
Keeping Industry Turning



Telephone:
+44 (0) 1484 557200

Email:
sales@brookcrompton.com

Website:
www.brookcrompton.com

