



# Keeping Industry Turning

## Series 30 - IE3 / IE4

Aluminium 80 to 225

Cast Iron 160 to 355



# Introduction

2

## Series 30 specification

Specification		
	Standard product	Option
<b>Frame material</b>	80 to 255 aluminium	-
	160 to 355 cast iron	-
<b>Enclosure</b>	IP55	IP56, IP65 or IP66
<b>Mounting option</b>	Foot (B3), Flange (B5), Face (B14)	V1, V3, V5 & V6
	Foot & Flange (B35), Foot & Face (B34)	V15, V18, V19 & V36
<b>Standard terminal box position</b>	Top	-
<b>Voltage</b>	3kW and below 230/400/50Hz & 460/60Hz	-
	4kW and above 400/690/50Hz & 460/60Hz	-
<b>Frequency</b>	50Hz & 60Hz	variable
<b>Cooling</b>	IC411	-
<b>Insulation</b>	class F (80K rise)	class H
<b>Thermal protection</b>	Thermistors (PTC)	Thermostats (PTO)
<b>Anti-condensation heaters</b>	aluminium range - not fitted	110V or 230V
	cast iron - 110 / 220V	-
<b>Ambient</b>	-20°C to +40°C	see page 12 for options
<b>Altitude</b>	up to 1000m above sea level	see page 12 for options
<b>Located bearing position</b>	80 to 225 aluminium - NDE located	-
	160 to 225 cast iron - NDE located	-
	250 to 355 cast iron - DE located	-
<b>Lubrication</b>	80 to 225 - greased for life bearings	-
	250 to 355 - through greasing	-
<b>Inverter Duty (with derate)</b>	Variable Torque: 10:1	option with derate
	Constant Torque: 2:1	option with derate
<b>Paint colour</b>	water blue (RAL 5021)	-

The above specification and options give a brief summary of features available for the Series 30 range. For a full listing of optional features, please contact Brook Crompton sales.

### Brook Crompton Keeping Industry Turning

Brook Crompton, the original innovator in electric motor development, is a leading provider of energy efficient electric motors.

With over 110 years' technical & design expertise, UK-based Brook Crompton delivers consistently reliable electric motors to a global market.

Trusted to power limitless industrial activities across diverse market sectors, the robust design of Brook Crompton's electric motors drives fans, pumps, compressors, conveyors and more, every second, of every day, of every year.

Renowned for their adaptability, Brook Crompton's extensive motor stock can be modified to suit the needs of different market sectors, with technical support from the company's knowledgeable team readily available to ensure the correct selection of motors for any application.

For bespoke situations and complete flexibility, Brook Crompton will design and manufacture to meet individual customer specifications.

Brook Crompton has a long-standing reputation for efficient customer service, supporting customers worldwide through its global network. Specialist Brook Crompton Motor Centres operate alongside approved product distributors throughout the UK, mainland Europe, Middle East, Canada, USA, and Asia Pacific.

Shaping the future of electric motors, Brook Crompton is focused on the development of new products that improve energy efficiency, offer lower cost of ownership throughout the motor lifetime and reduce environmental impact.

**Brook Crompton, the original innovator in electric motors.**

#### Quality assurance

Stringent quality procedures are observed from first design to finished product in accordance with the ISO 9001 documented quality systems.

All factories have been assessed to meet these requirements.

### Series 30

The Brook Crompton Series 30 range is a high quality standard range of electric motors with a specification suitable for most industrial applications.

It covers outputs from 0.55kW up to 400kW in frame sizes 80 to 355.

#### Benefits include:

- Full output range to meet your requirements
- Efficiencies comply with EN60034-30 (IE3)
- Robust construction for long life
- Mountings: foot, flange, face or combination
- Euro voltage: up to 3kW 230/400V; 4kW and above 400/690V
- Dual frequency (50 / 60Hz)
- IE3 efficiency, IE4 efficiency (75kW to 200kW)
- IP55
- Metal fan cover
- Metric entries
- Thermal protection fitted as standard
- 110 / 220V heaters std on the cast iron range
- Inverter duty

## Standards, environment & efficiency

### Standards

The Series 30 range of motors are manufactured to the international standards listed below:

Standards	
Performance	IEC 60034-1
Dimensions	IEC 60072-1
Mounting	IEC 60034-7
Enclosure protection	IEC 60034-5
Vibration	IEC 60034-14 (grade A)
Noise	IEC 60034-9

### Environment Enclosure

All motors have degrees of IP protection as defined in IEC EN 60034-5. The normal arrangement is IP55. See Specification (page 2) for alternatives.

### Motor cooling

Motors are cooled in accordance with IEC 60034-6. The normal arrangement is IC411 (Totally Enclosed Fan Ventilated) via a fan mounted at the non-drive end.

### European directives

The following European directives apply:

Compliance with European directives applying to AC induction motors				
Directives	Low voltage (LV)	Machinery (MD)	Electromagnetic compatibility (EMC)	Ecodesign regulation (ErP)
Reference numbers	2014/35/EU	2006/42/EC	2014/30/EU	2019/1781
Motor CE / UKCA* marked	Yes	No	No	Yes
Standards	EN 60034	Not applicable	EN 60034-1	EN 60034-30
Documentation for customers technical file	Declaration of conformity	Declaration of incorporation	Statement <sup>(1)</sup>	Declaration of conformity
Safety instructions with every motor	Yes	Yes	Yes	-
Comment	Relevant electrical equipment operating between 50 to 1000 volts AC	Statment <sup>(2)</sup>	Component	Minimum efficiency levels (see Ecodesign requirements AC induction motors below)

\* UKCA marked in accordance to the relevant Statutory Instruments, which are in-line with the EU regulations quoted above.  
<sup>(1)</sup> Motors operating from a correctly applied, sinusoidal (AC) supply meet the requirements of the EMC directive and are within the limits specified in standard EN 60034-1  
<sup>(2)</sup> When installed in accordance with our customer safety and installation and maintenance instructions, they can be put into service only when the machinery into which they are being incorporated, has been declared to be in conformity with the machinery directive in accordance with Article 4(2) and Annex IIB of that Directive (98/37/EEC)

### Ecodesign requirements AC induction motors

Ecodesign regulation [EU] 2019/1781, is introduced in two stages, stage one came into effect on the 1st July 2021, the second stage two years later 1st July 2023.

#### Stage one:

Stage one - 1st July 2021.

This stage introduces efficiency requirements for motors 0.12 to 0.74kW, which must now meet IE2 efficiency levels. Previously the IE3 efficiency requirement stopped at 375kW, this has now been increased to 1000kW.

In addition to the efficiency level changes above, the following motor types are to be introduced in stage one: 8 pole speeds, Brake motors, Hazardous area motors: Ex ec, Ex tb, Ex tc & Ex db. Totally Enclosed Air Overmmotors (IC418) and motors with duty cycles: S1, S3 > 80%, S6 > 80%.

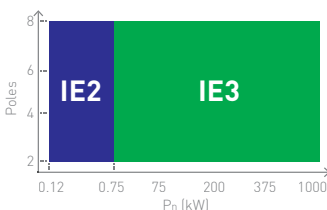

Introduction of IE2 0.12 to 0.74kW  
IE3 from 0.75kW to 1000kW

#### Stage two:

Stage two - 1st July 2023.

IE4 is introduced, this will be mandatory for motor outputs 75kW to 200kW in 2, 4 & 6 poles, but excludes ATEX motors according to 2014/34/EU and brake motors.

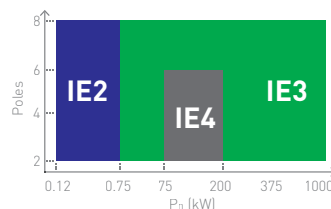

Introduction of IE4 75kW to 200kW

Please note: IE2 +VSD is no longer applicable.

Motors exempt from the new regulation:  
High voltage motors, Mining motors and Totally Enclosed Non-Ventilated (IC410) motors.

Stage two also introduces a minimum efficiency value of IE2 for single phase motors and Ex eb (increased safety) motors.

As in stage one, the following motors are exempt: High voltage motors, Mining motors and Totally Enclosed Non-Ventilated (IC410) motors.

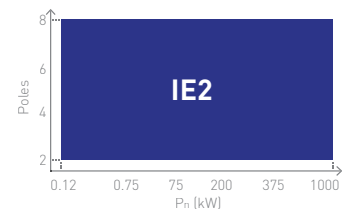

Introduction of Single phase & Ex eb 0.12kW to 1000kW

# Performance data

IE3

4

Outputs conforming to IEC 60034  
2 pole (3000min<sup>-1</sup>) - aluminium construction

Rated power		Full load speed in revolutions per minute	Frame reference and size	Full load current at rated voltage			Efficiency	Power factor	Full load torque	Direct on line starting torque ratio	Direct on line pull up torque ratio	Direct on line pull out torque ratio	Direct on line starting current ratio	Rotor inertia WK <sup>2</sup>	Mean sound pressure level @ 1m on no load	Motor weight
P <sub>N</sub>	n			I <sub>N</sub>	η	Cos φ										
kW	hp	min <sup>-1</sup>	Type	230V A	400V A	690V A	1.0 P <sub>N</sub> 0.75 P <sub>N</sub> 0.5 P <sub>N</sub>	1.0 P <sub>N</sub> 0.75 P <sub>N</sub> 0.5 P <sub>N</sub>	M <sub>N</sub> M <sub>A</sub> M <sub>N</sub>	M <sub>S</sub> M <sub>N</sub>	M <sub>K</sub> M <sub>N</sub>	I <sub>A</sub> I <sub>N</sub>	J kgm <sup>2</sup>	L <sub>PA</sub> dB(A)	kg	
0.75	1.0	2875	JP-DA80MA	3.13	1.80	-	{ 80.7 0.75 80.3 0.64 76.5 0.49 }		2.48	2.7	-	3.4	5.1	0.0009	59	9.0
1.1	1.5	2865	JP-DA80MB	4.33	2.49	-	{ 82.7 0.77 83.1 0.70 80.7 0.55 }		3.68	3.1	-	3.6	6.5	0.0011	60	10.3
1.5	2.0	2875	JP-DA90SA	5.52	3.17	-	{ 84.2 0.81 85.0 0.74 84.0 0.60 }		4.99	2.9	-	3.6	7.2	0.0018	63	13
2.2	3.0	2885	JP-DA90LA	7.89	4.54	-	{ 85.9 0.82 86.7 0.77 85.3 0.63 }		7.3	2.6	-	3.5	6.8	0.0022	64	17
3.0	4.0	2900	JP-DA100LA	10.1	5.81	-	{ 87.1 0.86 88.0 0.82 86.8 0.71 }		10.1	2.9	-	3.7	7.4	0.0041	69	22.4
4.0	5.5	2905	JP-DA112MA	-	7.53	4.37	{ 88.1 0.87 89.0 0.83 88.0 0.73 }		13.2	2.7	-	3.6	7.3	0.0068	76	27.5
5.5	7.5	2915	JP-DA132SA	-	10.6	6.16	{ 89.2 0.84 90.1 0.77 89.5 0.66 }		18.0	2.5	-	3.2	6.2	0.0165	67	44
7.5	10	2915	JP-DA132SB	-	14.0	8.10	{ 90.1 0.86 91.1 0.82 91.0 0.73 }		24.6	2.7	-	3.4	7.1	0.0201	67	50
11.0	15	2940	JP-DA160MA	-	20.0	11.6	{ 91.2 0.87 91.9 0.85 91.6 0.78 }		35.6	2.5	-	3.2	7.5	0.0430	67	99
15.0	20	2930	JP-DA160MB	-	26.6	15.4	{ 91.9 0.89 92.8 0.88 92.7 0.82 }		48.9	2.4	-	3.0	6.8	0.0515	67	103
18.5	25	2945	JP-DA160LA	-	32.5	18.9	{ 92.4 0.89 93.3 0.88 93.4 0.82 }		59.8	2.6	-	3.3	7.8	0.0616	68	118
22	30	2960	JP-DA180MA	-	37.9	22.0	{ 92.7 0.90 93.4 0.88 93.5 0.82 }		71.0	2.3	-	2.8	7.1	0.0927	68	135
30	40	2965	JP-DA200LA	-	52.2	30.3	{ 93.3 0.89 93.7 0.87 93.2 0.81 }		96.6	2.6	-	2.9	7.4	0.1701	71	213
37	50	2965	JP-DA200LB	-	63.8	37.0	{ 93.7 0.89 94.2 0.87 94.0 0.81 }		119	2.6	-	3.0	7.5	0.1877	71	220
45	60	2975	JP-DA225M	-	76.4	44.3	{ 94.0 0.91 94.3 0.89 93.9 0.84 }		144	2.6	-	3.3	8.1	0.3326	73	272

# Performance data

Outputs conforming to IEC 60034  
4 pole (1500min<sup>-1</sup>) - aluminium construction

Rated power		Full load speed in revolutions per minute	Frame reference and size	Full load current at rated voltage			Efficiency	Power factor	Full load torque	Direct on line starting torque ratio	Direct on line pull up torque ratio	Direct on line pull out torque ratio	Direct on line starting current ratio	Rotor inertia WK <sup>2</sup>	Mean sound pressure level @ 1m on no load	Motor weight
P <sub>N</sub>				I <sub>N</sub>												
kW	hp	n	Type	230V A	400V A	690V A	1.0 P <sub>N</sub> 0.75 P <sub>N</sub> 0.5 P <sub>N</sub>	1.0 P <sub>N</sub> 0.75 P <sub>N</sub> 0.5 P <sub>N</sub>	M <sub>N</sub>	M <sub>A</sub>	M <sub>S</sub>	M <sub>K</sub>	I <sub>A</sub>	J	L <sub>PA</sub>	kg
0.55	0.75	1430	JP-DA80MA	2.76	1.59	-	<b>80.8</b> 80.1 76.4	<b>0.62</b> 0.57 0.43	3.7	2.7	-	3.1	6.3	0.0017	50	10
0.75	1.0	1435	JP-DA80MB	3.49	2.01	-	<b>82.5</b> 82.3 79.0	<b>0.65</b> 0.56 0.43	5.0	3.0	-	3.5	6.5	0.0022	50	11.7
1.1	1.5	1440	JP-DA90SA	4.56	2.62	-	<b>84.1</b> 83.9 81.2	<b>0.72</b> 0.63 0.50	7.3	3.2	-	3.7	6.5	0.0035	51	14.5
1.5	2.0	1435	JP-DA90LA	6.09	3.50	-	<b>85.3</b> 85.5 83.4	<b>0.73</b> 0.66 0.50	10.0	3.3	-	3.7	6.6	0.0042	56	17
2.2	3.0	1445	JP-DA100LA	8.73	5.02	-	<b>86.7</b> 86.9 85.2	<b>0.73</b> 0.62 0.47	14.6	3.0	-	3.6	6.6	0.0049	57	22
3.0	4.0	1445	JP-DA100LB	11.3	6.50	-	<b>87.7</b> 88.2 87.2	<b>0.76</b> 0.67 0.53	19.8	3.1	-	3.7	6.8	0.0062	58	25
4.0	5.5	1445	JP-DA112MA	-	8.46	4.91	<b>88.6</b> 89.3 88.5	<b>0.77</b> 0.73 0.61	26.5	2.4	-	3.2	6.7	0.0124	59	31
5.5	7.5	1455	JP-DA132SA	-	11.3	6.60	<b>89.6</b> 90.7 90.5	<b>0.78</b> 0.74 0.62	36.0	2.7	-	3.1	6.3	0.0324	62	46
7.5	10	1460	JP-DA132MA	-	15.4	8.93	<b>90.4</b> 90.9 90.5	<b>0.78</b> 0.72 0.59	49.0	2.9	-	3.1	6.2	0.0429	62	59
11.0	15	1470	JP-DA160MA	-	21.7	12.6	<b>91.4</b> 92.0 91.6	<b>0.80</b> 0.78 0.68	71.8	2.6	-	3.2	7.0	0.086	61	101
15.0	20	1470	JP-DA160LA	-	29.4	17.0	<b>92.1</b> 92.7 92.4	<b>0.80</b> 0.73 0.63	97.2	2.7	-	3.3	7.1	0.113	61	123
18.5	25	1475	JP-DA180MA	-	36.0	20.9	<b>92.6</b> 93.0 92.7	<b>0.80</b> 0.76 0.67	120	2.4	-	2.7	6.2	0.156	62	137
22	30	1470	JP-DA180LA	-	42.2	24.4	<b>93.0</b> 93.9 94.0	<b>0.81</b> 0.78 0.69	143	2.6	-	2.9	6.5	0.179	63	166
30	40	1475	JP-DA200LA	-	53.3	30.9	<b>93.6</b> 94.4 94.5	<b>0.87</b> 0.85 0.78	194	2.3	-	2.6	6.3	0.308	63	207
37	50	1480	JP-DA225SA	-	66.6	38.6	<b>93.9</b> 94.4 94.2	<b>0.85</b> 0.81 0.73	239	2.5	-	2.9	7.1	0.469	67	255
45	60	1480	JP-DA225MA	-	79.6	46.2	<b>94.2</b> 94.8 94.9	<b>0.87</b> 0.84 0.77	290	2.5	-	2.8	7.0	0.542	65	285

# Performance data

IE3

6

Outputs conforming to IEC 60034  
6 pole (1000min<sup>-1</sup>) - aluminium construction

Rated power		Full load speed in revolutions per minute	Frame reference and size	Full load current at rated voltage			Efficiency	Power factor	Full load torque	Direct on line starting torque ratio	Direct on line pull up torque ratio	Direct on line pull out torque ratio	Direct on line starting current ratio	Rotor inertia WK <sup>2</sup>	Mean sound pressure level @ 1m on no load	Motor weight
P <sub>N</sub>	n			I <sub>N</sub>	η	Cos φ										
kW	hp	min <sup>-1</sup>	Type	230V A	400V A	690V A	1.0 P <sub>N</sub> 0.75 P <sub>N</sub> 0.5 P <sub>N</sub>	1.0 P <sub>N</sub> 0.75 P <sub>N</sub> 0.5 P <sub>N</sub>	M <sub>N</sub> Nm	M <sub>A</sub> M <sub>N</sub>	M <sub>S</sub> M <sub>N</sub>	M <sub>K</sub> M <sub>N</sub>	I <sub>A</sub> I <sub>N</sub>	J kgm <sup>2</sup>	L <sub>PA</sub> dB(A)	kg
3.0	4.0	965	JP-DA132SA	6.93	4.02	-	<b>85.6</b> 86.4 85.9	<b>0.73</b> 0.66 0.53	29.8	2.2	-	2.9	5.4	0.032	57	38
4.0	5.5	970	JP-DA132MA	-	8.90	5.10	<b>86.8</b> 87.4 86.6	<b>0.75</b> 0.66 0.53	39.2	2.6	-	3.4	6.2	0.0413	57	47
5.5	7.5	970	JP-DA132MB	-	12.8	7.4	<b>88.0</b> 88.3 87.2	<b>0.70</b> 0.65 0.53	54.2	2.6	-	3.3	6.4	0.055	57	58
7.5	10	970	JP-DA160MA	-	16.8	9.74	<b>89.1</b> 89.5 88.3	<b>0.72</b> 0.68 0.55	73.5	2.3	-	3.6	6.6	0.096	60	89
11.0	15	975	JP-DA160LA	-	23.0	13.3	<b>90.3</b> 90.8 90.3	<b>0.77</b> 0.70 0.57	108	2.1	-	3.2	6.8	0.142	60	115
15.0	20	975	JP-DA180LA	-	30.6	17.8	<b>91.2</b> 92.2 92.3	<b>0.78</b> 0.73 0.62	147	2.3	-	2.9	6.1	0.185	61	144
18.5	25	980	JP-DA200LA	-	37.1	21.5	<b>91.7</b> 92.4 92.3	<b>0.78</b> 0.73 0.62	180	2.2	-	2.7	5.7	0.321	64	179
22	30	980	JP-DA200LB	-	43.7	25.3	<b>92.2</b> 93.0 92.9	<b>0.79</b> 0.74 0.63	214	2.3	-	2.7	6.0	0.378	63	197
30	40	985	JP-DA225M	-	60.9	35.3	<b>92.9</b> 93.3 93.1	<b>0.77</b> 0.71 0.62	291	2.4	-	2.8	6.3	0.591	62	281

# Performance data

Outputs conforming to IEC 60034  
2 pole (3000min<sup>-1</sup>) - cast iron construction

Rated power		Full load speed in revolutions per minute	Frame reference and size	Full load current at rated voltage			Efficiency		Power factor	Full load torque		Direct on line starting torque ratio		Direct on line pull up torque ratio		Direct on line pull out torque ratio		Rotor inertia WK <sup>2</sup>	Mean sound pressure level @ 1m on no load	Motor weight
P <sub>N</sub>	n			I <sub>N</sub>	η	cos φ	M <sub>N</sub>	M <sub>A</sub>	M <sub>S</sub>	M <sub>K</sub>	I <sub>A</sub>	J	L <sub>PA</sub>	kg						
kW	hp	min <sup>-1</sup>	Type	230V A	400V A	690V A	1.0 P <sub>N</sub> 0.75 P <sub>N</sub> 0.5 P <sub>N</sub>	1.0 P <sub>N</sub> 0.75 P <sub>N</sub> 0.5 P <sub>N</sub>	M <sub>N</sub>	M <sub>A</sub>	M <sub>S</sub>	M <sub>K</sub>	I <sub>A</sub>	J	L <sub>PA</sub>	kg				
11.0	15	2940	JP-DF160MA	-	20.0	11.6	{ 91.2 91.9 91.6 }	{ 0.87 0.82 0.72 }	35.7	2.4	-	2.9	6.4	0.0388	67	112				
15.0	20	2930	JP-DF160MB	-	26.6	15.4	{ 91.9 92.8 92.7 }	{ 0.89 0.87 0.81 }	48.9	2.5	-	3.0	6.5	0.0474	67	124				
18.5	25	2940	JP-DF160LA	-	32.5	18.9	{ 92.4 93.3 93.4 }	{ 0.89 0.86 0.80 }	60.1	2.5	-	3.1	6.5	0.0563	68	145				
22	30	2960	JP-DF180MA	-	37.9	22.0	{ 92.7 93.4 93.5 }	{ 0.90 0.88 0.82 }	71.0	2.3	-	2.8	7.1	0.0927	68	180				
30	40	2965	JP-DF200LA	-	52.2	30.3	{ 93.3 93.7 93.2 }	{ 0.89 0.87 0.81 }	96.9	2.6	-	2.9	7.4	0.1701	71	235				
37	50	2965	JP-DF200LB	-	63.8	37.0	{ 93.7 94.2 94.0 }	{ 0.89 0.87 0.81 }	119	2.6	-	3.0	7.5	0.1877	71	252				
45	60	2975	JP-DF225MA	-	76.4	44.3	{ 94.0 94.3 93.9 }	{ 0.91 0.89 0.84 }	144	2.6	-	3.3	8.1	0.3326	73	312				
55	75	2975	JP-DF250MA	-	92.5	53.6	{ 94.3 94.7 94.4 }	{ 0.91 0.90 0.85 }	177	2.5	-	3.0	7.8	0.4748	75	425				
75	100	2985	JP-DF280SA	-	129	75	{ 94.7 94.6 93.8 }	{ 0.89 0.86 0.80 }	240	2.7	-	3.4	8.7	0.8298	75	604				
90	125	2985	JP-DF280MA	-	153	88.9	{ 95.0 95.1 94.6 }	{ 0.89 0.86 0.80 }	288	2.7	-	3.3	8.8	0.9858	77	646				
110	150	2985	JP-DF315SA	-	183	106	{ 95.2 95.0 94.2 }	{ 0.91 0.89 0.84 }	352	2.2	-	3.4	8.2	1.703	78	862				
132	175	2985	JP-DF315MA	-	218	126	{ 95.4 95.3 94.7 }	{ 0.92 0.90 0.86 }	422	2.2	-	3.2	8.2	1.864	78	950				
160	215	2985	JP-DF315MB	-	264	153	{ 95.6 95.8 95.3 }	{ 0.92 0.91 0.85 }	512	2.3	-	3.5	8.3	2.185	78	970				
200	270	2985	JP-DF315MD	-	330	191	{ 95.8 96.0 95.7 }	{ 0.91 0.90 0.86 }	640	2.3	-	3.3	8.4	2.313	78	1130				
250	335	2985	JP-DF355MA	-	418	242	{ 95.8 95.7 95.2 }	{ 0.90 0.87 0.80 }	800	2.3	-	3.5	8.4	3.811	80	1270				
315	420	2985	JP-DF355MB	-	518	300	{ 95.8 95.9 95.5 }	{ 0.92 0.90 0.85 }	1008	2.3	-	3.5	8.6	4.628	80	1460				
355	475	2985	JP-DF355MC	-	568	329	{ 95.8 96.0 95.7 }	{ 0.94 0.93 0.89 }	1136	2.3	-	3.4	8.8	5.717	81	1524				
400	535	2985	JP-DF355LA	-	643	373	{ 95.8 95.9 95.6 }	{ 0.94 0.92 0.86 }	1280	2.5	-	3.8	9.0	5.739	82	1735				

# Performance data

IE3

8

Outputs conforming to IEC 60034  
4 pole (1500min<sup>-1</sup>) - cast iron construction

Rated power  
Full load speed in revolutions per minute  
Frame reference and size  
Full load current at rated voltage  
Efficiency  
Power factor  
Full load torque  
Direct on line starting torque ratio  
Direct on line pull up torque ratio  
Direct on line pull out torque ratio  
Direct on line starting current ratio  
Rotor inertia WK<sup>2</sup>  
Mean sound pressure level @ 1m on no load  
Motor weight

P <sub>N</sub>		n min <sup>-1</sup>	Type	I <sub>N</sub>			η		Cos φ		M <sub>N</sub> Nm	M <sub>A</sub> M <sub>N</sub>	M <sub>S</sub> M <sub>N</sub>	M <sub>K</sub> M <sub>N</sub>	I <sub>A</sub> I <sub>N</sub>	J kgm <sup>2</sup>	L <sub>PA</sub> dB(A)	kg
kW	hp			230V A	400V A	690V A	1.0 P <sub>N</sub> 0.75 P <sub>N</sub> 0.5 P <sub>N</sub>	1.0 P <sub>N</sub> 0.75 P <sub>N</sub> 0.5 P <sub>N</sub>										
11.0	15	1470	JP-DF160MA	-	21.7	12.6	{ 91.4 92.0 91.6 }	{ 0.80 0.75 0.64 }		71.5	2.8	-	3.1	6.8	0.0778	61	120	
15.0	20	1470	JP-DF160LA	-	29.4	17.0	{ 92.1 92.7 92.4 }	{ 0.80 0.74 0.63 }		97.4	2.8	-	3.2	6.9	0.1021	61	142	
18.5	25	1475	JP-DF180MA	-	36.0	20.9	{ 92.6 93.5 93.6 }	{ 0.80 0.76 0.67 }		120	2.4	-	2.7	6.2	0.1559	62	166	
22	30	1470	JP-DF180LA	-	42.2	24.4	{ 93.0 93.9 94.0 }	{ 0.81 0.78 0.69 }		143	2.6	-	2.9	6.5	0.1786	63	185	
30	40	1475	JP-DF200LA	-	53.3	30.9	{ 93.6 94.4 94.5 }	{ 0.87 0.85 0.78 }		194	2.3	-	2.6	6.3	0.3084	63	246	
37	50	1480	JP-DF225SA	-	66.6	38.6	{ 93.9 94.4 94.2 }	{ 0.85 0.81 0.73 }		239	2.5	-	2.9	7.1	0.469	67	307	
45	60	1480	JP-DF225MA	-	79.6	46.2	{ 94.2 94.8 94.9 }	{ 0.87 0.84 0.77 }		290	2.5	-	2.8	7.0	0.542	65	316	
55	75	1485	JP-DF250MA	-	97.5	56.5	{ 94.6 95.0 94.8 }	{ 0.86 0.84 0.77 }		354	2.7	-	2.9	7.5	0.9026	66	450	
75	100	1490	JP-DF280SA	-	136	79	{ 95.0 95.4 95.1 }	{ 0.84 0.82 0.75 }		481	2.5	-	2.9	6.7	1.556	67	614	
90	125	1485	JP-DF280MA	-	161	94	{ 95.2 95.6 95.5 }	{ 0.85 0.83 0.77 }		579	2.6	-	2.9	6.9	1.756	68	663	
110	150	1490	JP-DF315SA	-	194	112	{ 95.4 95.5 95.0 }	{ 0.86 0.82 0.73 }		705	2.5	-	3.4	7.9	3.294	72	873	
132	175	1490	JP-DF315MA	-	232	134	{ 95.6 95.8 95.3 }	{ 0.86 0.83 0.75 }		846	2.6	-	3.3	8.0	3.606	72	930	
160	215	1490	JP-DF315MB	-	276	160	{ 95.8 96.0 95.9 }	{ 0.87 0.85 0.79 }		1025	2.6	-	3.2	8.0	4.104	73	1000	
200	270	1490	JP-DF315MD	-	345	200	{ 96.0 96.3 96.1 }	{ 0.87 0.84 0.78 }		1282	2.6	-	3.3	8.2	4.728	73	1158	
250	335	1490	JP-DF355MA	-	442	256	{ 96.0 96.2 96.0 }	{ 0.85 0.80 0.71 }		1602	2.3	-	3.3	7.9	6.663	74	1504	
315	420	1490	JP-DF355MB	-	543	315	{ 96.0 96.2 95.9 }	{ 0.87 0.84 0.77 }		2019	2.3	-	3.2	7.8	8.147	74	1460	
355	475	1490	JP-DF355MC	-	611	354	{ 96.0 96.3 96.2 }	{ 0.87 0.84 0.75 }		2275	2.2	-	3.2	8.0	9.445	75	1612	
400	535	1490	JP-DF355LA	-	703	408	{ 96.0 96.1 95.9 }	{ 0.86 0.81 0.72 }		2564	2.3	-	3.3	8.1	10.6	76	1825	

# Performance data

Outputs conforming to IEC 60034  
6 pole (1000min<sup>-1</sup>) - cast iron construction

Rated power		Full load speed in revolutions per minute	Frame reference and size	Full load current at rated voltage			Efficiency		Power factor	Full load torque		Direct on line starting torque ratio	Direct on line pull up torque ratio	Direct on line pull out torque ratio	Direct on line starting current ratio	Rotor inertia WK <sup>2</sup>	Mean sound pressure level @ 1m on no load	Motor weight
P <sub>N</sub>	n			I <sub>N</sub>	η	cos φ	M <sub>N</sub>	M <sub>A</sub>	M <sub>S</sub>	M <sub>K</sub>	I <sub>A</sub>	J	L <sub>PA</sub>	kg				
kW	hp	min <sup>-1</sup>	Type	230V A	400V A	690V A	1.0 P <sub>N</sub> 0.75 P <sub>N</sub> 0.5 P <sub>N</sub>	1.0 P <sub>N</sub> 0.75 P <sub>N</sub> 0.5 P <sub>N</sub>	M <sub>N</sub>	M <sub>A</sub>	M <sub>S</sub>	M <sub>K</sub>	I <sub>A</sub>	J	L <sub>PA</sub>	kg		
7.5	10	970	JP-DF160MA	-	16.8	9.74	<b>89.1</b> 89.5 88.3	<b>0.72</b> 0.64 0.51	73.8	2.3	-	2.8	6.2	0.0793	60	105		
11.0	15	975	JP-DF160LA	-	23.0	13.3	<b>90.3</b> 90.8 90.3	<b>0.77</b> 0.70 0.58	108	2.5	-	3.1	6.7	0.1154	60	143		
15.0	20	975	JP-DF180LA	-	30.6	17.8	<b>91.2</b> 92.2 92.3	<b>0.78</b> 0.73 0.62	147	2.3	-	2.9	6.1	0.1846	61	172		
18.5	25	980	JP-DF200LA	-	37.1	21.5	<b>91.7</b> 92.4 92.3	<b>0.78</b> 0.73 0.62	180	2.2	-	2.7	5.7	0.3211	64	222		
22	30	980	JP-DF200LB	-	43.7	25.3	<b>92.2</b> 93.0 92.9	<b>0.79</b> 0.74 0.63	214	2.3	-	2.7	6.0	0.3775	63	232		
30	40	985	JP-DF225MA	-	60.9	35.3	<b>92.9</b> 93.3 93.1	<b>0.77</b> 0.71 0.62	291	2.4	-	2.8	6.3	0.591	62	311		
37	50	990	JP-DF250MA	-	74.3	43.1	<b>93.3</b> 93.6 92.9	<b>0.77</b> 0.71 0.60	357	2.7	-	3.2	7.2	0.9345	63	405		
45	60	990	JP-DF280SA	-	90	52	<b>93.7</b> 94.1 93.8	<b>0.77</b> 0.72 0.61	434	2.5	-	2.8	6.7	1.49	66	570		
55	75	990	JP-DF280MA	-	107	62	<b>94.1</b> 94.5 94.2	<b>0.79</b> 0.74 0.65	531	2.6	-	2.8	6.7	1.82	70	582		
75	100	990	JP-DF315SA	-	139	81	<b>94.6</b> 95.0 94.9	<b>0.82</b> 0.79 0.71	723	2.0	-	2.2	5.7	2.99	73	796		
90	125	990	JP-DF315MA	-	162	94	<b>94.9</b> 95.3 95.2	<b>0.84</b> 0.82 0.75	868	2.3	-	2.5	6.1	3.47	71	930		
110	150	990	JP-DF315MB	-	199	115	<b>95.1</b> 95.7 95.8	<b>0.84</b> 0.82 0.74	1061	2.4	-	2.6	6.3	4.26	73	957		
132	175	990	JP-DF315MC	-	234	136	<b>95.4</b> 96.0 96.2	<b>0.85</b> 0.83 0.77	1273	2.3	-	2.4	6.1	5.21	72	1116		
160	215	990	JP-DF355MA	-	289	168	<b>95.6</b> 95.9 95.7	<b>0.84</b> 0.81 0.73	1543	2.5	-	2.8	7.5	7.58	75	1360		
200	270	990	JP-DF355MB	-	359	208	<b>95.8</b> 96.1 96.0	<b>0.84</b> 0.80 0.72	1929	2.5	-	2.9	7.7	9.25	75	1520		
250	335	990	JP-DF355MC	-	442	256	<b>95.8</b> 96.1 96.0	<b>0.85</b> 0.83 0.74	2411	2.4	-	2.8	7.6	10.6	75	1675		
315	420	990	JP-DF355LA	-	551	319	<b>95.8</b> 96.4 96.3	<b>0.86</b> 0.84 0.76	3038	2.4	-	2.8	7.7	13.1	75	1940		
355	475	990	JP-DF355LB	-	622	361	<b>95.8</b> 96.3 96.4	<b>0.86</b> 0.84 0.77	3424	2.4	-	2.8	7.8	16.2	75	2155		

# Performance data

IE4

10

Outputs conforming to IEC 60034  
2 pole (3000min<sup>-1</sup>) & 4 pole (1500min<sup>-1</sup>)- cast iron construction

Rated power		Full load speed in revolutions per minute	Frame reference and size	Full load current at rated voltage			Efficiency	Power factor	Full load torque	Direct on line starting torque ratio	Direct on line pull up torque ratio	Direct on line pull out torque ratio	Direct on line starting current ratio	Rotor inertia WK <sup>2</sup>	Mean sound pressure level @ 1m on no load	Motor weight
P <sub>N</sub>	n			I <sub>N</sub>												
kW	hp	min <sup>-1</sup>	Type	230V A	400V A	690V A	1.0 P <sub>N</sub> 0.75 P <sub>N</sub> 0.5 P <sub>N</sub>	1.0 P <sub>N</sub> 0.75 P <sub>N</sub> 0.5 P <sub>N</sub>	M <sub>N</sub> Nm	M <sub>A</sub> M <sub>N</sub>	M <sub>S</sub> M <sub>N</sub>	M <sub>K</sub> M <sub>N</sub>	I <sub>A</sub> I <sub>N</sub>	J kgm <sup>2</sup>	L <sub>PA</sub> dB(A)	kg
75	100	2981	JSP-DF280SA	-	124	71.6	{ 95.6 95.8 95.6 }	{ 0.91 - - }	240	2.1	-	3.0	7.6	1.17	-	651
90	125	2981	JSP-DF280MA	-	149	86.0	{ 95.8 96.0 95.7 }	{ 0.91 - - }	288	2.3	-	3.1	7.8	1.27	-	732
110	150	2983	JSP-DF315SA	-	181	105	{ 96.0 96.2 95.8 }	{ 0.91 - - }	351	2.4	-	3.2	8.0	2.59	-	1105
132	175	2983	JSP-DF315MA	-	216	125	{ 96.2 96.3 96.0 }	{ 0.92 - - }	423	2.4	-	3.1	7.9	2.91	-	1184
160	215	2983	JSP-DF315MB	-	261	151	{ 96.3 96.5 96.2 }	{ 0.92 - - }	512	2.5	-	3.1	7.9	3.23	-	1326
200	270	2983	JSP-DF315MD	-	325	188	{ 96.5 96.4 96.0 }	{ 0.92 - - }	640	2.5	-	3.0	8.0	3.60	-	1408

Rated power		Full load speed in revolutions per minute	Frame reference and size	Full load current at rated voltage			Efficiency	Power factor	Full load torque	Direct on line starting torque ratio	Direct on line pull up torque ratio	Direct on line pull out torque ratio	Direct on line starting current ratio	Rotor inertia WK <sup>2</sup>	Mean sound pressure level @ 1m on no load	Motor weight
P <sub>N</sub>	n			I <sub>N</sub>												
kW	hp	min <sup>-1</sup>	Type	230V A	400V A	690V A	1.0 P <sub>N</sub> 0.75 P <sub>N</sub> 0.5 P <sub>N</sub>	1.0 P <sub>N</sub> 0.75 P <sub>N</sub> 0.5 P <sub>N</sub>	M <sub>N</sub> Nm	M <sub>A</sub> M <sub>N</sub>	M <sub>S</sub> M <sub>N</sub>	M <sub>K</sub> M <sub>N</sub>	I <sub>A</sub> I <sub>N</sub>	J kgm <sup>2</sup>	L <sub>PA</sub> dB(A)	kg
75	100	1489	JSP-DF280SA	-	127	73.3	{ 96.0 96.2 95.8 }	{ 0.89 - - }	482	3.2	-	3.6	8.4	1.99	-	647
90	125	1490	JSP-DF280MA	-	157	90.6	{ 96.1 96.3 95.9 }	{ 0.86 - - }	576	3.3	-	3.7	8.4	2.45	-	779
110	150	1491	JSP-DF315SA	-	188	109	{ 96.3 96.5 96.1 }	{ 0.88 - - }	705	2.7	-	3.5	8.2	4.41	-	992
132	175	1492	JSP-DF315MA	-	225	130	{ 96.4 96.5 96.1 }	{ 0.88 - - }	846	2.7	-	3.4	8.3	5.14	-	1086
160	215	1490	JSP-DF315MB	-	272	157	{ 96.6 96.8 96.5 }	{ 0.88 - - }	1026	2.9	-	3.5	8.4	6.37	-	1243
200	270	1490	JSP-DF315MD	-	336	194	{ 96.7 96.8 96.6 }	{ 0.89 - - }	1282	2.7	-	3.2	7.8	7.96	-	1509

# Performance data

IE4

Outputs conforming to IEC 60034  
6 pole (1000min<sup>-1</sup>) - cast iron construction

Rated power		Full load speed in revolutions per minute	Frame reference and size	Full load current at rated voltage			Efficiency		Power factor	Full load torque	Direct on line starting torque ratio	Direct on line pull up torque ratio	Direct on line pull out torque ratio	Direct on line starting current ratio	Rotor inertia WK <sup>2</sup>	Mean sound pressure level @ 1m on no load	Motor weight
P <sub>N</sub>				I <sub>N</sub>			η	cos φ									
kW	hp	n min <sup>-1</sup>	Type	230V A	400V A	690V A	1.0 P <sub>N</sub>	1.0 P <sub>N</sub>	M <sub>N</sub>	M <sub>A</sub>	M <sub>S</sub>	M <sub>K</sub>	I <sub>A</sub>	J	L <sub>PA</sub>	kg	
							0.75 P <sub>N</sub>	0.75 P <sub>N</sub>									
							0.5 P <sub>N</sub>	0.5 P <sub>N</sub>									
75	100	992	JSP-DF315SA	-	132	76.2	{ 95.4 95.3 94.8 }	{ 0.86 - - }	724	2.2	-	3.0	7.0	4.35	-	870	
90	125	992	JSP-DF315MA	-	160	92.4	{ 95.6 95.8 95.3 }	{ 0.85 - - }	948	2.3	-	3.0	7.0	5.13	-	948	
110	150	992	JSP-DF315MB	-	193	111	{ 95.8 95.8 95.3 }	{ 0.86 - - }	1062	2.3	-	2.9	6.9	5.91	-	1028	
132	175	992	JSP-DF315MC	-	231	133	{ 96.0 96.2 95.9 }	{ 0.86 - - }	1274	2.3	-	2.9	6.9	7.15	-	1217	
160	215	995	JSP-DF355MA	-	289	167	{ 96.2 96.1 95.6 }	{ 0.83 - - }	1535	2.2	-	2.6	6.8	9.05	-	1565	
200	270	995	JSP-DF355MB	-	361	208	{ 96.3 96.2 95.5 }	{ 0.83 - - }	1919	2.3	-	2.6	7.0	11.4	-	1670	

# Increased outputs & Environment

12

## Increased outputs

### Increased output for frame

The Series 30 range can be offered with increased outputs for their relevant frame size in aluminium and cast-iron construction.

The two tables to the right show the increased outputs available for frames against speed.

Please contact your local Brook Crompton sales office for further information.

### Increased outputs - Aluminium frames - IE3 efficiency

2 pole	Type	4 pole	Type	6 Pole	Type
1.5kW	JP-DA80MK	10kW	JP-DA132MK	37kW	JP-DA225MK
3.0kW	JP-DA90LK	18.5kW	JP-DA160LK		
4.0kW	JP-DA100LK	30kW	JP-DA180LK		
5.5kW	JP-DA112MK	37kW	JP-DA200LK		
11kW	JP-DA132MK	55kW	JP-DA225MK		
22kW	JP-DA160LK				
45kW	JP-DA200LK				
55kW	JP-DA225MK				

### Increased outputs - Cast iron frames - IE3 efficiency

2 pole	Type	4 pole	Type	6 Pole	Type
22kW	JP-DF160LK	18.5kW	JP-DF160LK	37kW	JP-DF225MK
30kW	JP-DF180LK	30kW	JP-DF180LK	45kW	JP-DF250MK
45kW	JP-DF200LK	37kW	JP-DF200LK	75kW	JP-DF280MK
55kW	JP-DF225MK	55kW	JP-DF225MK	160kW	JP-DF315MK
75kW	JP-DF250MK	75kW	JP-DF250MK		
110kW	JP-DF280MK	110kW	JP-DF280MK		
250kW	JP-DF315LK	250kW	JP-DF315MK		

## Environmental conditions

### High ambient temperatures and High Altitudes

The kW ratings listed in this catalogue apply to standard motors operating in ambient temperatures not exceeding 40°C and altitudes up to 1000m above sea level.

When operating a standard motor in higher ambient temperatures or at higher altitudes, derating may be necessary in order to maintain its operating temperature limit (Class B).

The listed factors in the table to the right should be used for derating.

For derate factors utilising class F 'total temperature', then please contact your local Brook Crompton sales office.

### Class 'F' insulation - Class 'B' rise - derate factors

Temp (°C)	Altitude (m)						
	1000	1500	2000	2500	3000	3500	4000
0	1.00	0.97	0.94	0.90	0.86	0.82	0.77
40	1.00	0.97	0.94	0.90	0.86	0.82	0.77
45	0.96	0.93	0.90	0.86	0.82	0.79	0.74
50	0.92	0.89	0.86	0.83	0.79	0.75	0.71
55	0.87	0.84	0.82	0.78	0.75	0.71	0.67
60	0.82	0.79	0.77	0.74	0.70	0.67	0.63

Page notes for pages 4-11

Typical speed / current curve

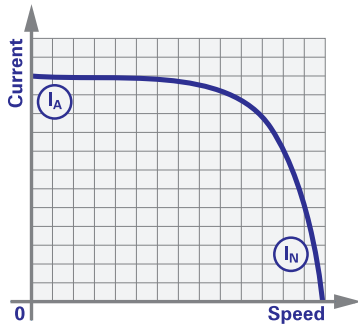

(I<sub>A</sub>) - Starting current  
(I<sub>N</sub>) - Full load current

Typical speed / torque curve

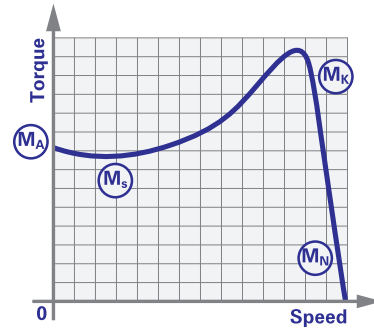

(M<sub>A</sub>) - Starting torque or locked rotor torque  
(M<sub>S</sub>) - Pull up torque or run up torque  
(M<sub>K</sub>) - Pull out torque or breakdown torque  
(M<sub>N</sub>) - Full load torque.

During the run up period in Star, there must be an adequate excess of motor torque over the load torque. The change to Delta must not occur until the motor is near the operating speed.

Refer to Brook Crompton for running up against a load in excess of 70% full load during Star Delta starting.

Performance figures are subject to IEC tolerances.  
Performance figures are based on a 400 volt winding.

Rotor inertia:  $J \text{ (WK}^2 \text{ or WR}^2) = \frac{GD^2}{4}$        $J \text{ in lb ft}^2 = \frac{kgm^2}{0.042}$

## Motor nameplate

### Motor nameplate

Typical images of the Series 30 motor nameplate.  
CE and UKCA marked.

<b>BROOK CROMPTON</b> HUDDERSFIELD UK		3 - AC MOTOR IEC 60034		CE UKCA		Series 30		www.brookcrompton.com	
TYPE JP-DA100LA		P/No 100J249203		S 1		Th.C1. 155(F)		Tomb 40 °C	
No 16200093545		YR 21		V		Hz		kW	
r/min		A		cos φ		η %		1.0 0.75 0.5	
Δ 230		50		1445		8.70		0.73	
Y 400		60		1445		5.00		0.73	
IE3		86.7		86.9		85.2			
Y 460		60		1725		4.20		0.73	
89.5		90.1		89.2					
DE 6206 ZZ C3		IP 55		22		kg			
NDE 6206 ZZ C3		IC 411							

230/400/3/50 & 460/3/60 dual frequency stamping

<b>BROOK CROMPTON</b> HUDDERSFIELD UK		3 - AC MOTOR IEC 60034		CE UKCA		Series 30		www.brookcrompton.com	
TYPE JP-DA132SB		P/No 132J329203		S 1		Th.C1. 155(F)		Tomb 40 °C	
No 16181234567		YR 22		V		Hz		kW	
r/min		A		cos φ		η %		1.0 0.75 0.5	
Δ 400		50		2915		14.0		0.86	
Y 690		60		2915		8.1		0.86	
IE3		90.1		91.1		91.0			
Δ 460		60		3498		12.2		0.86	
90.2		90.8		90.5					
DE 6208 ZZ C3		IP 55		49		kg			
NDE 6208 ZZ C3		IC 411							

400/690/3/50 & 460/3/60 dual frequency stamping

# Dimensions - IEC

14

Foot, Flange and Face mounting  
Frame sizes 80 to 225 aluminium (JP-DA)

IM B3  
IM 1001  
Mounting options

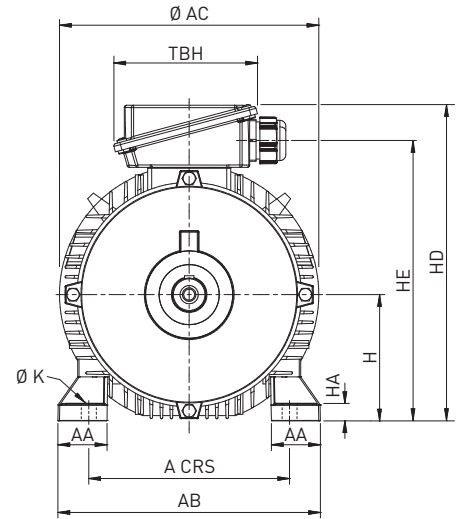
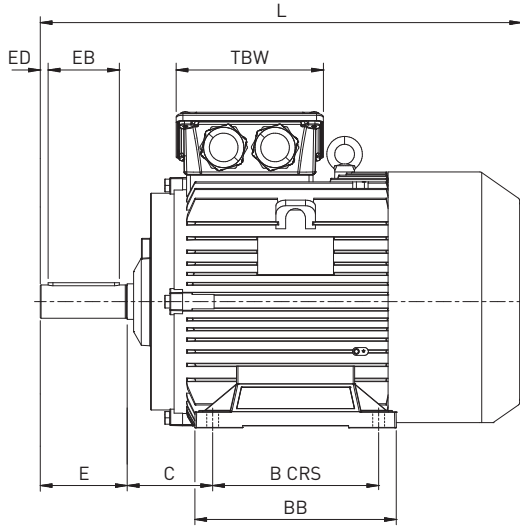

IM B5 / IM B35  
IM 3001 / IM 2001  
Mounting options

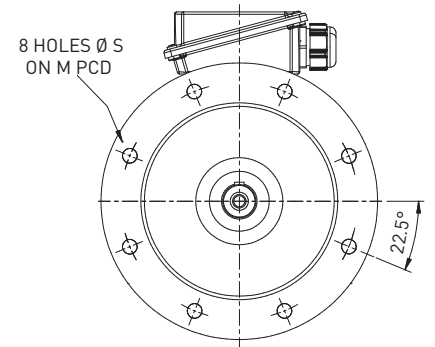
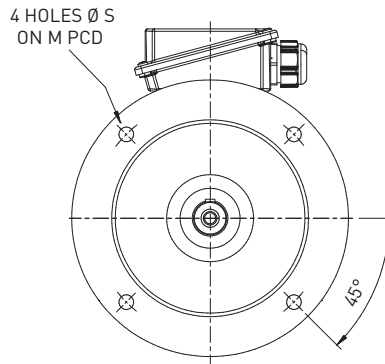
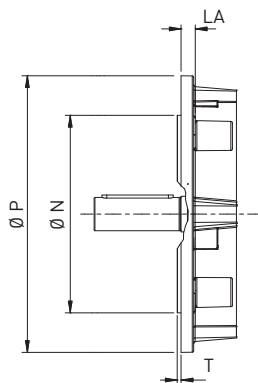

8 holes at 22.5° on frame sizes 225 and above

IM B14 / B34  
IM 3601 / IM 2101  
Mounting options

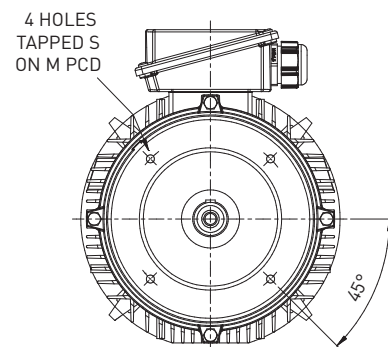
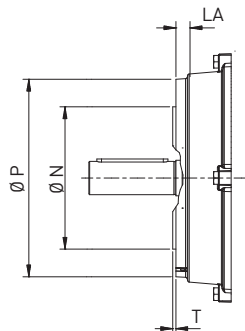

# Dimensions - IEC

Foot, Flange and Face mounting  
Frame sizes 80 to 225 aluminium (JP-DA)

## General Dimensions - Aluminium

Type	A	B	C	H	K	4 Pole +		2 Pole		AA	AB	Ø AC	BB	HA	HD	HE	TBW	TBH	KK
						L	L												
JP-DA80M	125	100	50	80	10 x 15	289	289	36	164	160	124	12	195	158	113	103	1 x CM25		
JP-DA90S	140	100	56	90	10 x 15	313	313	40	184	180	124	12	215	172	113	103	1 x CM25		
JP-DA90L	140	125	56	90	10 x 15	338	338	40	184	180	149	12	215	172	113	103	1 x CM25		
JP-DA100L	160	140	63	100	12 x 18	375	375	45	208	204	174	13	236	193	113	103	2 x CM25		
JP-DA112M	190	140	70	112	12 x 18	390	390	45	232	228	174	13	260	218	113	103	2 x CM25		
JP-DA132S	216	140	89	132	12 x 18	429	429	50	274	270	174	15	318	266	139	137	2 x CM32		
JP-DA132M	216	178	89	132	12 x 18	469	469	50	274	270	213	15	318	266	139	137	2 x CM32		
JP-DA160M	254	210	108	160	15 x 19	610	610	62	332	328	255	22	400	355	186	182	2 x CM40		
JP-DA160L	254	254	108	160	15 x 19	655	655	62	332	328	299	22	400	355	186	182	2 x CM40		
JP-DA180M	279	241	121	180	15 x 19	701	701	64	364	358	286	22	433	388	186	182	2 x CM40		
JP-DA180L	279	279	121	180	15 x 19	701	701	64	364	358	324	22	433	388	186	182	2 x CM40		
JP-DA200L	318	305	133	200	19 x 24	781	781	69	408	408	355	27	485	435	226	220	2 x CM50		
JP-DA225S	356	286	149	225	19 x 24	841	-	84	470	460	336	30	534	484	226	220	2 x CM50		
JP-DA225M	356	311	149	225	19 x 24	841	811	84	470	460	361	30	534	484	226	220	2 x CM50		

## Flange & Face - Aluminium

Type	IM B5 flange mounting						Face - Aluminium										
	M	N	P	S	T	LA	IM B14 face mounting										
	M	N	P	S	T	LA	M	N	P	S	T	LA					
JP-DA80	165	130	200	12	3.5	12	100	80	120	M6	3	12					
JP-DA90	165	130	200	12	3.5	12	115	95	140	M8	3	16					
JP-DA100	215	180	250	14.4	4	15	130	110	160	M8	3.5	16					
JP-DA112	215	180	250	14.5	4	15	130	110	160	M8	3.5	16					
JP-DA132	265	230	300	14.5	4	15	165	130	200	M10	3.5	20					
JP-DA160	300	250	350	18.5	5	18	215	180	250	M12	4	24					
JP-DA180	300	250	350	18.5	5	18	-	-	-	-	-	-					
JP-DA200	350	300	400	18.5	5	22	-	-	-	-	-	-					
JP-DA225	400	350	450	18.5	5	22	-	-	-	-	-	-					

## Shaft

Type	4 pole +								2 pole							
	Ø D	E	F	G	GD	EB	ED	DH	Ø D	E	F	G	GD	EB	ED	DH
JP-DA80	19	40	6	15.5	6	32	4	M6	19	40	6	15.5	6	32	4	M6
JP-DA90	24	50	8	20	7	40	5	M8	24	50	8	20	7	40	5	M8
JP-DA100	28	60	8	24	7	50	5	M10	28	60	8	24	7	50	5	M10
JP-DA112	28	60	8	24	7	50	5	M10	28	60	8	24	7	50	5	M10
JP-DA132	38	80	10	33	8	70	5	M12	38	80	10	33	8	70	5	M12
JP-DA160	42	110	12	37	8	90	10	M16	42	110	12	37	8	90	10	M16
JP-DA180	48	110	14	42.5	9	100	5	M16	48	110	14	42.5	9	100	5	M16
JP-DA200	55	110	16	49	10	100	5	M20	55	110	16	49	10	100	5	M20
JP-DA225	60	140	18	53	11	125	5	M20	55	110	16	49	10	100	5	M20

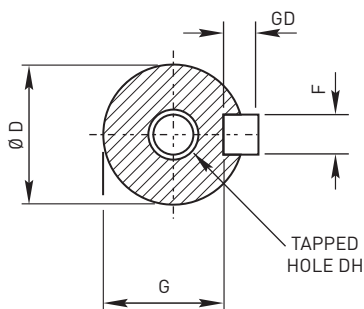

Shaft dimensions

# Dimensions - IEC

16

Foot, Flange and Face mounting  
 Frame sizes 160 to 355 cast iron (JP-DF / JSP-DF)

IM B3  
 IM 1001  
 Mounting options

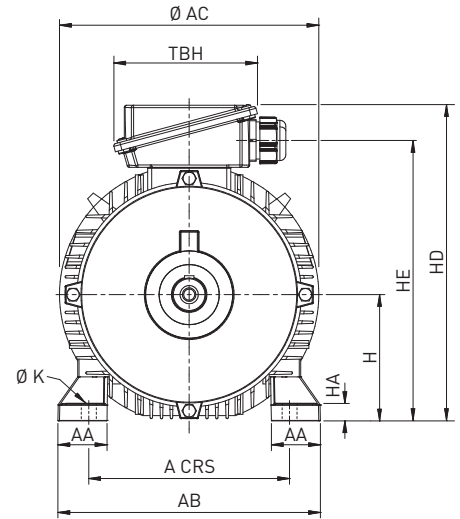
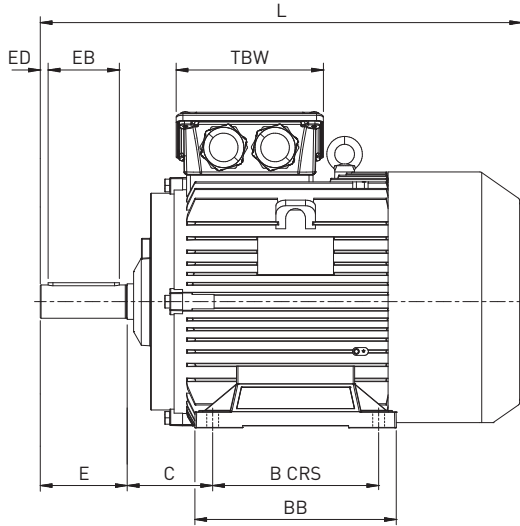

IM B5 / IM B35  
 IM 3001 / IM 2001  
 Mounting options

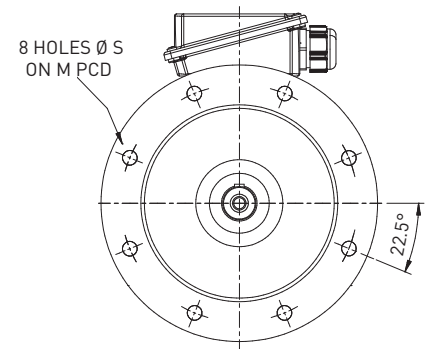
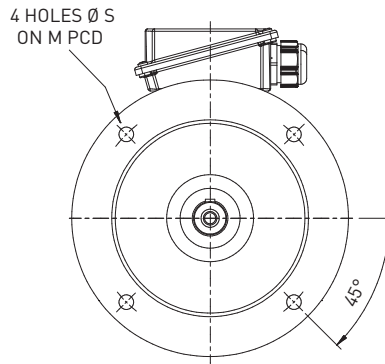
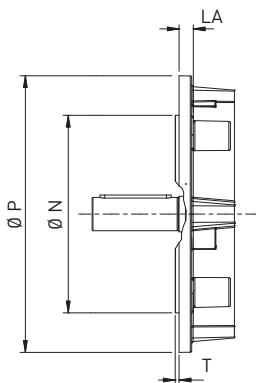

8 holes at 22.5° on frame sizes 225 and above

IM B14 / B34  
 IM 3601 / IM 2101  
 Mounting options

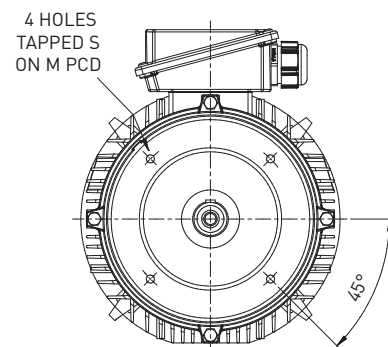
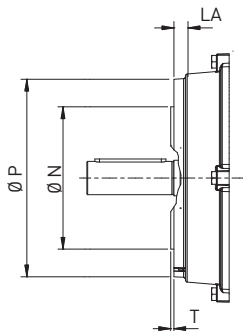

# Dimensions - IEC

Foot, Flange and Face mounting  
Frame sizes 160 to 355 cast iron (JP-DF / JSP-DF)

Type	A	B	C	H	K	4 Pole +		2 Pole		AA	AB	Ø AC	BB	HA	HD	HE	TBW	TBH	KK
						L	L	L	L										
JP-DF160M	254	210	108	160	15	610	610	62	332	328	255	22	400	355	186	182	2 x CM40		
JP-DF160L	254	254	108	160	15	655	655	62	332	328	300	22	400	355	186	182	2 x CM40		
JP-DF180M	279	241	121	180	15	666	666	64	364	358	287	22	433	388	186	182	2 x CM40		
JP-DF180L	279	279	121	180	15	701	701	64	364	358	325	22	433	388	186	182	2 x CM40		
JP-DF200L	318	305	133	200	19	781	781	80	410	408	354	25	485	435	226	220	2 x CM50		
JP-DF225S	356	286	149	225	19	841	-	90	466	460	368	30	534	484	226	220	2 x CM50		
JP-DF225M	356	311	149	534	19	841	811	90	466	460	368	30	534	484	226	220	2 x CM50		
JP-DF250M	406	349	168	250	24	907	907	100	516	516	421	36	612	554	256	250	2 x CM63		
JP/JPS-DF280S	457	368	190	280	24	957	957	110	606	600	440	44	679	621	256	250	2 x CM63		
JP/JPS-DF280M	457	419	190	280	24	1012	1012	110	606	600	491	44	679	621	256	250	2 x CM63		
JP/JPS-DF315S	508	406	216	315	28	1156	1126	135	680	675	540	47	810	731	319	450	2 x CM63		
JP/JPS-DF315M	508	457	216	315	28	1156	1126	135	680	675	540	47	810	731	319	450	2 x CM63		
JP/JPS-DF355M	610	560	254	355	28	1465	1395	165	770	760	666	52	885	805	319	450	2 x CM63		
JP/JPS-DF355L	610	630	254	355	28	1665	1595	165	770	760	900	52	885	805	319	450	2 x CM63		

Type	IM B5 flange mounting						Face - Cast Iron										
	M	N	P	S	T	LA	IM B14 face mounting										
	M	N	P	S	T	LA	M	N	P	S	T	LA					
JP-DF160	300	250	350	18.5	5	18	215	180	250	M12	4	24					
JP-DF180	300	250	350	18.5	5	18	-	-	-	-	-	-					
JP-DF200	350	300	400	18.5	5	22	-	-	-	-	-	-					
JP-DF225	400	350	450	18.5	5	22	-	-	-	-	-	-					
JP-DF250	500	450	550	18.5	5	26	-	-	-	-	-	-					
JP/JPS-DF280	500	450	550	18.5	5	26	-	-	-	-	-	-					
JP/JPS-DF315	600	550	660	24	6	26	-	-	-	-	-	-					
JP/JPS-DF355	740	680	800	24	6	35	-	-	-	-	-	-					

Type	4 pole +								2 pole							
	Ø D	E	F	G	GD	EB	ED	DH	Ø D	E	F	G	GD	EB	ED	DH
JP-DF160	42	110	12	37	8	90	10	M16	42	110	12	37	8	90	10	M16
JP-DF180	48	110	14	42.5	9	100	5	M16	48	110	14	42.5	9	100	5	M16
JP-DF200	55	110	16	49	10	100	5	M20	55	110	16	49	10	100	5	M20
JP-DF225	60	140	18	53	11	125	5	M20	55	110	16	49	10	100	5	M20
JP-DF250	65	140	18	58	11	125	5	M20	60	140	18	53	11	125	5	M20
JP/JPS-DF280	75	140	20	67.5	12	125	5	M20	65	140	18	58	11	125	5	M20
JP/JPS-DF315	80	170	22	71	14	140	10	M20	65	140	18	58	11	125	5	M20
JP/JPS-DF355	100	210	28	90	16	180	10	M24	75	140	20	67.5	12	125	10	M20

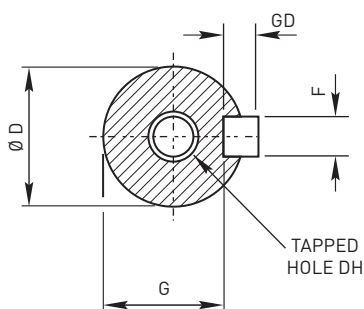

Shaft dimensions

### Bearings

The Series 30 range of motors are fitted with single row deep groove ball bearings.

The bearing size for each frame size can be found in the 'Bearing references' table to the right.

Aluminium motors frames 80 to 225, frame reference starting with 'JP-DA' or 'JP-UDA' have a located NDE bearing.

Cast iron motors frames with frame reference starting with 'JP-DF', 'JP-UDF' or 'JPS-UDF' are NDE located in frame sizes 160 to 225 and DE located from 250 to 355 frames.

### Bearing references

Type		Poles	DE bearing	NDE bearing
Aluminium	Cast Iron			
JP-DA80	-	All	6204ZZ CM	6204ZZ CM
JP-DA90	-	All	6205ZZ CM	6205ZZ CM
JP-DA100	-	All	6206ZZ CM	6206ZZ CM
JP-DA112	-	All	6206ZZ CM	6206ZZ CM
JP-DA132	-	All	6208ZZ C3	6208ZZ C3
JP-DA160	JP-DF160	All	6309ZZ C3	6209ZZ C3
JP-DA180	JP-DF180	All	6310ZZ C3	6210ZZ C3
JP-DA200	JP-DF200	All	6312ZZ C3	6212ZZ C3
JP-DA225	JP-DF225	All	6313ZZ C3	6213ZZ C3
-	JP-DF250	All	6315 C3	6315 C3
-	JP/JPS-DF280	All	6316 C3	6316 C3
-	JP/JPS-DF315	2P	6316 C3	6316 C3
-	JP/JPS-DF315	4P +	6319 C3	6319 C3
-	JP/JPS-DF355	2P	6319 C3	6319 C3
-	JP/JPS-DF355	4P +	6322 C3	6322 C3

'ZZ' indicates 'greased for life' bearings.

Sealed for life bearings are fitted with a premium quality grease to ensure exceptional reliability under a wide range of operating conditions.

### Relubrication intervals

The Series 30 aluminium range of motors are fitted with 'sealed for life' bearings

The cast iron range 160 to 225 are also fitted with 'greased for life' bearings

The Relubrication intervals table to the right shows the grease quantity and relubrication intervals for frame sizes 250 to 355.

The cast iron range frame type reference starting with 'JP-DF', 'JP-UDF' or 'JPS-UDF' are NDE located in frame sizes 160 to 225 and DE located from 250 to 355 frames.

### Relubrication intervals

Type	DE Bearing Quantity (gms)	NDE Bearing Quantity (gms)	Lubrication intervals (hours)			
			3000 min <sup>-1</sup>	1500 min <sup>-1</sup>	1000 min <sup>-1</sup>	750 min <sup>-1</sup>
JP-DF250	30	30	4000	11000	15000	18000
JP/JPS-DF280	33	33	3500	100000	14500	17000
JP/JPS-DF315	33	33	2500	-	-	-
JP/JPS-DF315	45	45	-	8500	13000	16000
JP/JPS-DF355	45	45	2000	-	-	-
JP/JPS-DF355	60	60	-	6500	11000	14000

Figures above are based on a horizontal mounted motor for both standard design and alternative design.

Bearings are filled with a high quality lithium based grease.

The regreasing time should be reduced if the bearing operating temperature is in excess of 70°C.

### Drip proof canopy

A drip proof canopy (impact canopy) can be fitted to the Series 30 range.

To find the overall length of a motor fitted with a drip proof canopy, please add dimension 'DPC' to dimension 'L'.

### Overall length + DPC

Type	L + DPC
80 to 100	'L' + 39 mm
112 to 132	'L' + 50 mm
160 to 225	'L' + 60 mm
250 to 355	'L' + 75 mm

For dimension 'L' see the 'General dimensions' tables on pages 14 & 15.

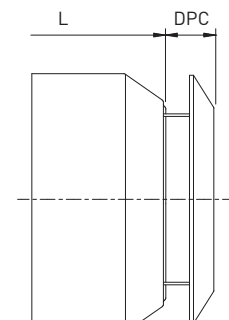

### Material type

Component material type

### Material type

Component	Frame size					
	80 - 112	132	160	180	200 - 225	250 - 355
Frame	Al	Al	Al or CI	Al or CI	Al or CI	CI
Endshields	Al	Al	Al or CI	Al or CI	CI	CI
Flange (B5)	Al	Al	CI	CI	CI	CI
Face (B14)	Al	CI	CI	-	-	-
Face (B14B)	Al	CI	-	-	-	-

Al - Aluminium  
CI - Cast Iron

# Dimension page notes & mounting codes

## Page notes for pages 14-17

All dimensions shown are in millimetres

Dimensions should not be used for installation purposes unless specially endorsed

B5 mounted motors have suffix '-D' in the frame reference, eg JP-DA132MA-D and B3/B5 mounted motors have suffix '-H' in the frame reference, eg JP-DA132MA-H.

B14 mounted motors have suffix 'C' in the frame reference, eg JP-DA132MA-C and B3/B14 mounted motors have suffix '-H' in the frame reference, eg JP-DA132MA-H.

Shaft		
Dim $\varnothing D$	Tol.	Limits
11 to 14	j6	+0.008 -0.003
19 to 28	j6	+0.009 -0.004
38 to 48	k6	+0.018 +0.002
55 to 80	m6	+0.030 +0.011
85 to 110	m6	+0.035 +0.013

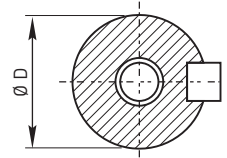

Flange			IEC 60072	
Dim $\varnothing N$	Tol.	Limits		
110	j6	+0.013 -0.009		
130	j6	+0.014 -0.011		
230 to 250	j6	+0.016 -0.013		
300	h6	+0.000 -0.032		
350	h6	+0.000 -0.036		
450	h6	+0.000 -0.040		
550	h6	+0.000 -0.044		
680	h6	+0.000 -0.050		

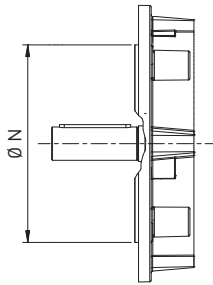

Face			IEC 60072	
Dim $\varnothing N$	Tol.	Limits		
70 and 80	j6	+0.013 -0.009		
1395 and 110	j6	+0.014 -0.011		
130	j6	+0.016 -0.013		
230	j6	+0.016 -0.016		

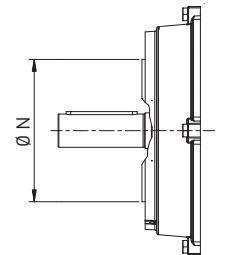

## Mounting codes

### Horizontal shaft:

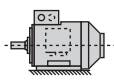

IM B3  
IM 1001  
foot mounted

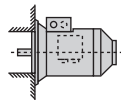

IM B5  
IM 3001  
flange at DE  
no feet



IM B6  
IM 1051  
foot wall mounted with  
feet on left-hand side  
when viewed from DE



IM B7  
IM 1061  
foot wall mounted with  
feet on right-hand side  
when viewed from DE



IM B8  
IM 1071  
ceiling mounted  
with feet  
above motor

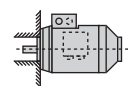

IM B14  
IM 3601  
face at DE  
no feet

### Vertical shaft:

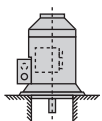

IM V1  
IM 3011  
flange at DE  
shaft down  
no feet

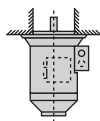

IM V3  
IM 3031  
flange at DE  
shaft up  
no feet

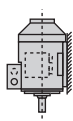

IM V5  
IM 1011  
vertical foot  
wall mounted  
shaft down

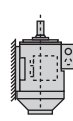

IM V6  
IM 1031  
vertical foot  
wall mounted  
shaft up

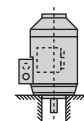

IM V18  
IM 3611  
face at DE  
shaft down  
no feet

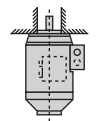

IM V19  
IM 3631  
face at DE  
shaft up  
no feet

Combinations of the above mountings are possible e.g. B3/B5 (IM2001)

## Europe

### **Brook Crompton UK Ltd**

St Thomas' Road Huddersfield  
West Yorkshire HD1 3LJ UK  
T: +44 (0) 1484 557200  
F: +44 (0) 1484 557201  
E: sales@brookcrompton.com  
www.brookcrompton.com

### **Brook Crompton UK LTD - Sede secondaria in Italia**

Via De Chirico, 9/11  
42124 - Reggio Emilia (RE)  
T: +39 0522 345055  
E: italy@brookcrompton.com  
www.brookcrompton.com

## Asia

### **Brook Crompton Asia Pacific Pte Ltd**

19 Keppel Road #08-01, Jit Poh Building  
Singapore 089058  
T: +65 6227 0308  
F: +65 6227 0605  
E: marketing@brookcrompton-ap.com  
www.brookcrompton.com

### **Brook Crompton Australia Pty Ltd**

5/220 New Cleveland Road,  
Tingalpa, Queensland  
Australia  
T: +61 (02) 413 431 978  
E: australia@brookcrompton.com  
www.brookcrompton.com

## Americas

### **Brook Crompton Inc**

1100 E. 222nd Street  
Euclid, Ohio 44117, USA  
T: +1 800 668 6779  
T: +1 - 800 463 8917  
E: sales@brookcromptonna.com  
www.brookcromptonna.com

### **Brook Crompton Ltd**

264 Attwell Drive  
Toronto, Ontario, M9W 5B2, Canada  
T: + 416 675 3844 (Toronto)  
T: +1 888 668 9843 (Quebec)  
E: sales@brookcromptonna.com  
www.brookcromptonna.com

Every care has been taken to ensure the accuracy of the information contained in this publication, but, due to a policy of continuous development and improvement the right is reserved to supply products which may differ slightly from those illustrated and described in this publication