

SIEMENS

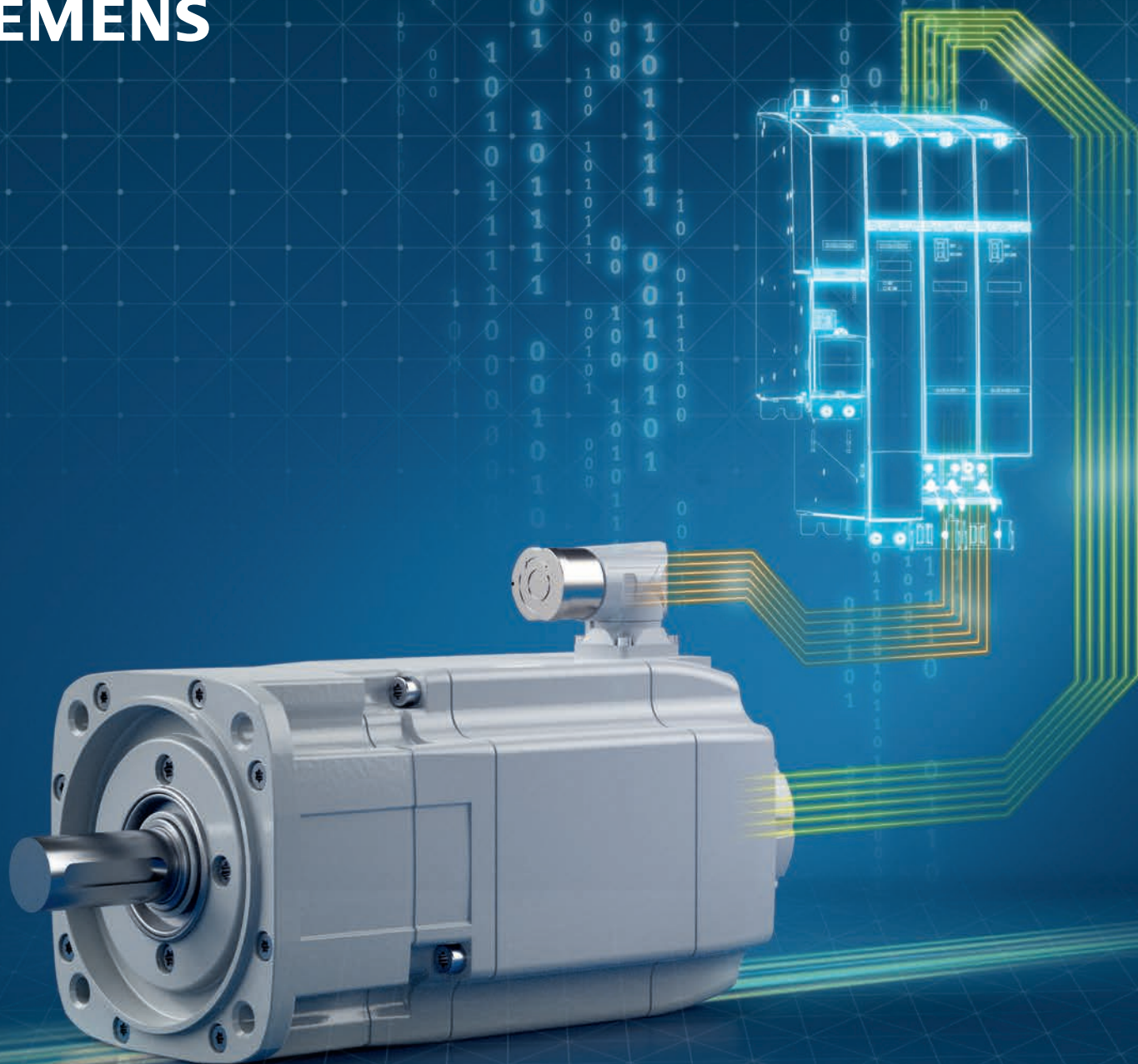

SIMOTICS

compact, dynamic and rugged

Experience a higher level of precision

SIMOTICS S Servomotors

SIMOTICS motors for every motion control application



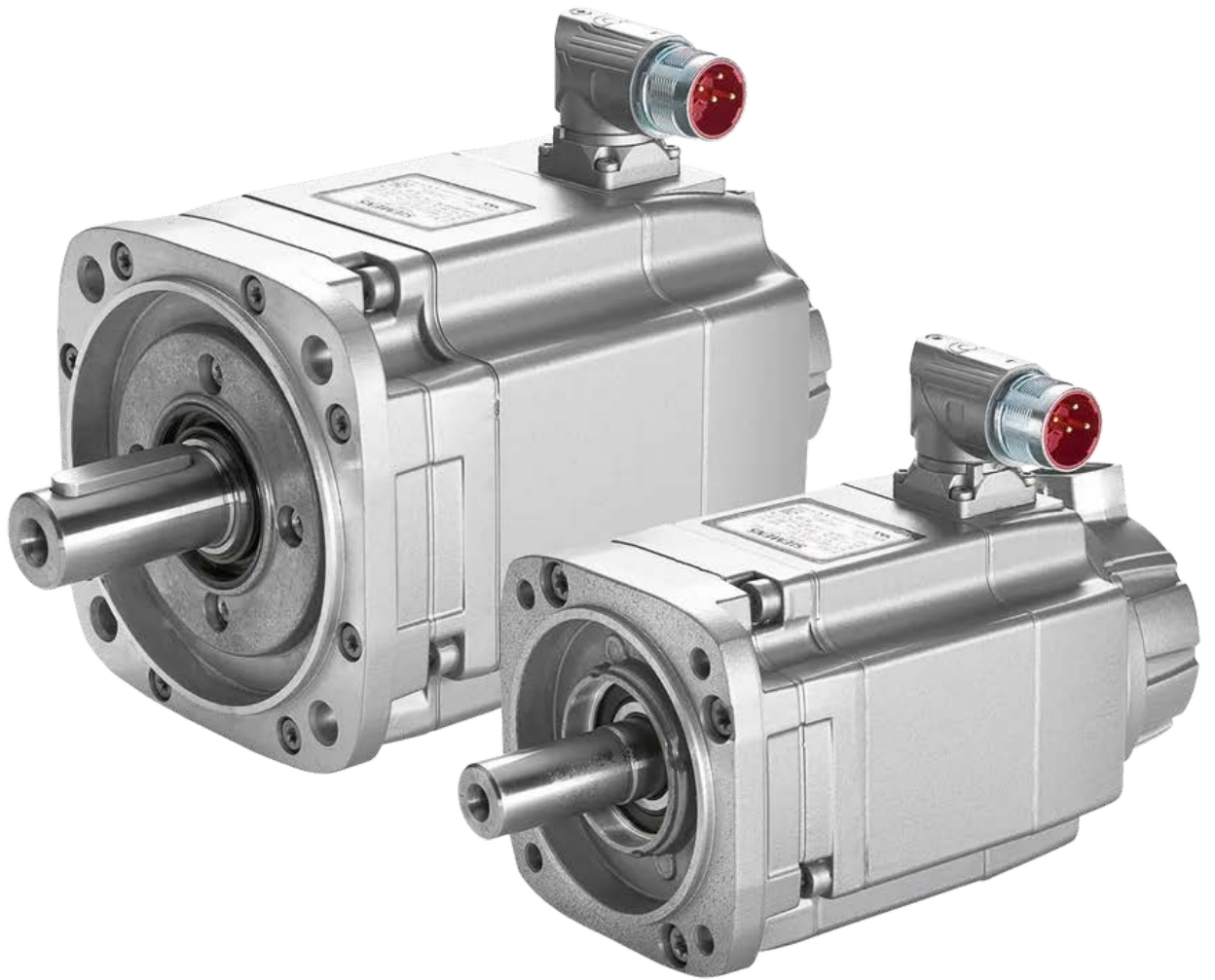

| Move it!

Since the development of the dynamo-electric principle by Werner von Siemens in 1866, innovative motor technology represents a core business of our company. In addition to low-voltage, DC and high-voltage motors, **SIMOTICS motors** have firmly established themselves in many industries when it comes to addressing demanding motion control applications.

The correct solution

Whether for precise and repeatable positioning, constant speed and high dynamic motion, long traversing paths or fast velocity changes—the **Siemens SIMOTICS portfolio of servo, main, linear and torque motors** has the optimum solution for every motion control application.

SIMOTICS motion control motors are based upon:

- More than 150 years of experience and innovation in electric motor technology
- The widest range of motors worldwide with optimum solutions for motion control applications in every manufacturing industry and power class
- Can be fully integrated into the drive-train to create overall systems, perfectly addressing the control concept
- Rugged and compact design for reliable, low-maintenance operation with the highest dynamic performance and precision
- A global network of skill sets and worldwide service around the clock

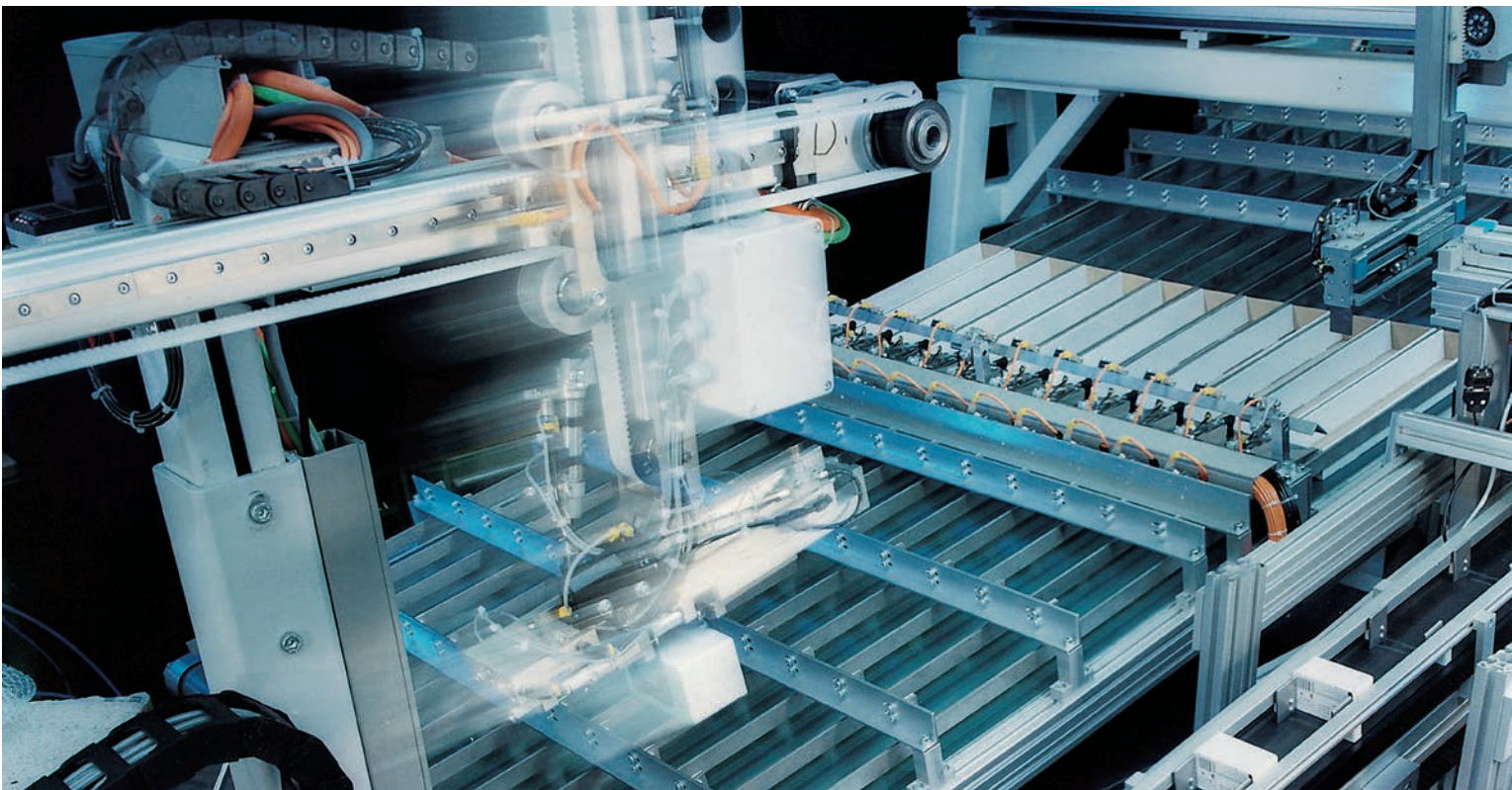

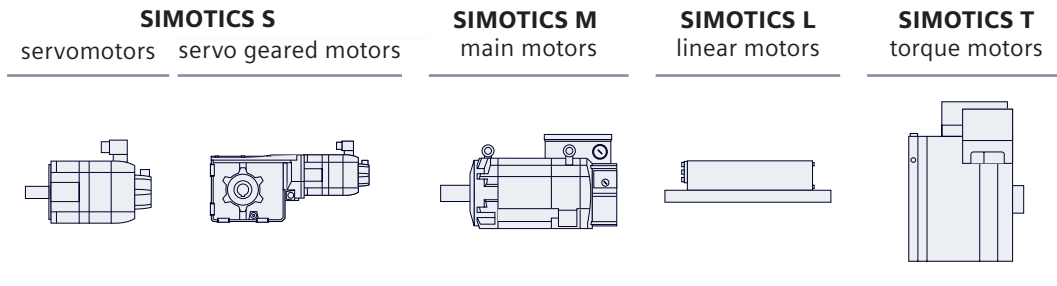

SIMOTICS motion control motors are perfectly harmonized and coordinated for operation with our SINAMICS family of drives. This simplifies the engineering and commissioning needed for high-performance applications in machine building and plant construction.

Optimum integration in the drive and control system

To optimize interaction with the drive, Siemens motors have a DRIVE-CLiQ interface to quickly transfer data—and transparently monitor important motor information. In addition, SIMOTICS motion control motors operate perfectly with SIMATIC, SINUMERIK and SIMOTION control systems from Siemens.

For specific questions related to your application, simply e-mail us: [✉ mc.us@siemens.com](mailto:mc.us@siemens.com)

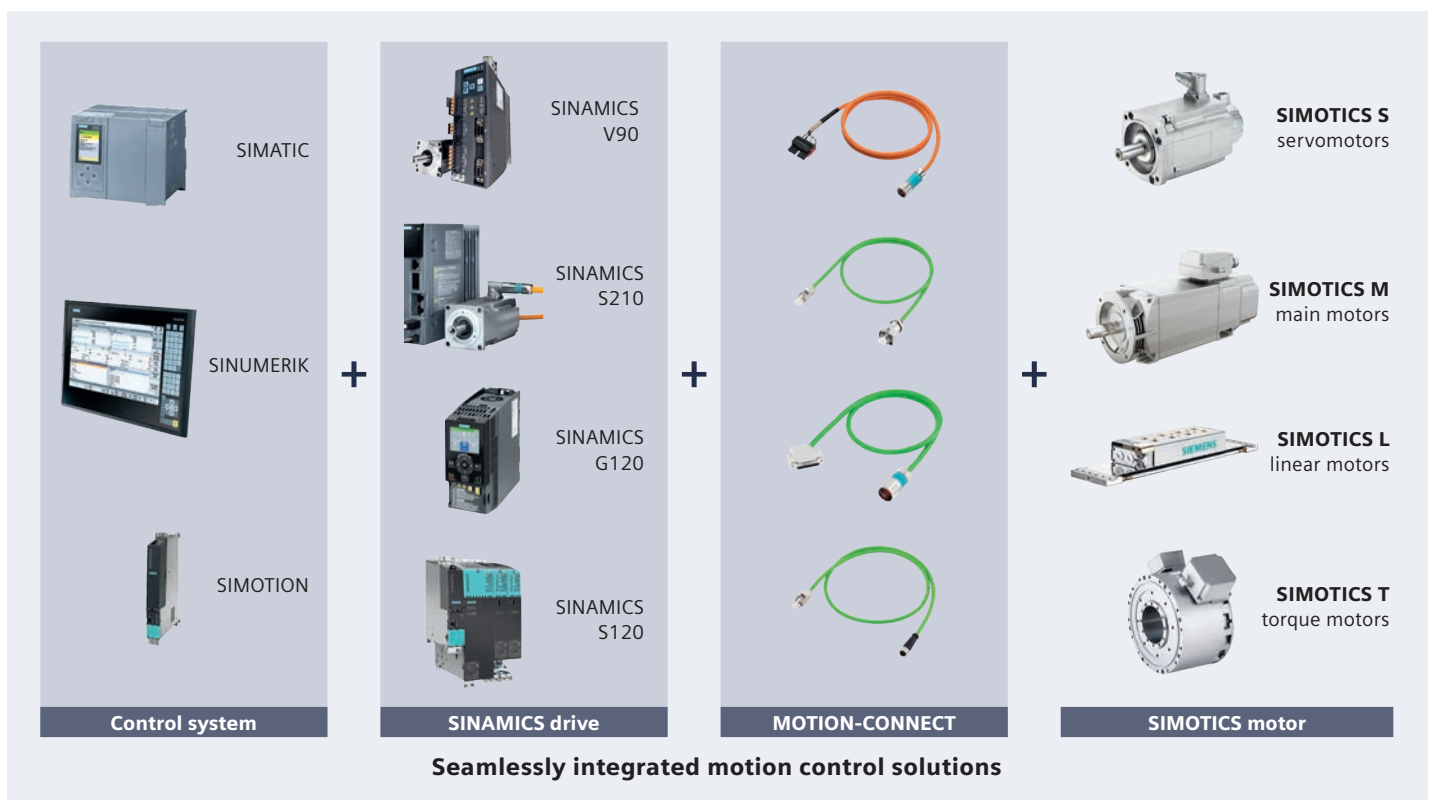

| Servomotors for every motion application

No matter whether positioning, angular synchronism, cyclic drives or path control in CNC machines—with SIMOTICS servomotors, you benefit from high dynamic performance, precision, compactness and ruggedness.

SIMOTICS S-1FK7

Highlights

3 versions with different moment of inertia versions—Compact, High Dynamic, High Inertia

High efficiency 300% overload capability

Resistant to shock and vibration—the encoder is mechanically decoupled

Optional absolute encoder, incremental encoder or resolver

Installation and service-friendly using a rotatable quick-release connector and field-replaceable encoder

Digital DRIVE-CLiQ interface with electronic type plate for optimal connectivity to SINAMICS S120 drives

Optionally with different types of gearboxes and backlash-free holding brake

Cooling methods—natural cooling and forced ventilation

Typical application areas

- Packaging machines
 - Plastics and textile machines
 - Digital printing machines
 - Wood, glass, ceramic and stone processing machines
 - Robots, handling systems and conveyor technology
 - Feed and auxiliary axes for CNC machines
-

Cost-efficient, flexible and universal

With our SIMOTICS S-1FK7 servomotors, depending upon the requirements relating to dynamic performance, control response, precision and space, there are three moment-of-inertia versions to select from—when required, also in combination with a gearbox.

SIMOTICS S-1FK7 Compact (CT)

High power density with a short length makes our SIMOTICS S-1FK7 Compact (CT) motors the clear choice for universal use in applications where space is restricted.

SIMOTICS S-1FK7 High Dynamic (HD)

These motors set themselves apart as a result of their low rotor diameter. This minimizes the intrinsic moment of inertia and facilitates high-dynamic performance. This also makes them ideal when it comes to motion sequences with very short cycle times demanding high-dynamic performance.

SIMOTICS S-1FK7 High Inertia (HI)

The increased intrinsic moment of inertia of our SIMOTICS S-1FK7 High Inertia (HI) motors ensures an extremely rugged control response—ideal for applications with high and variable load moments of inertia.

SIMOTICS S-1FK7 with mounted planetary gearbox

When specified, we can also supply S-1FK7 motors with a mounted planetary gearbox. High-precision and economic planetary gearboxes are available to address a wide range of applications. You benefit from high, smooth-running properties and compactness for motion control applications.

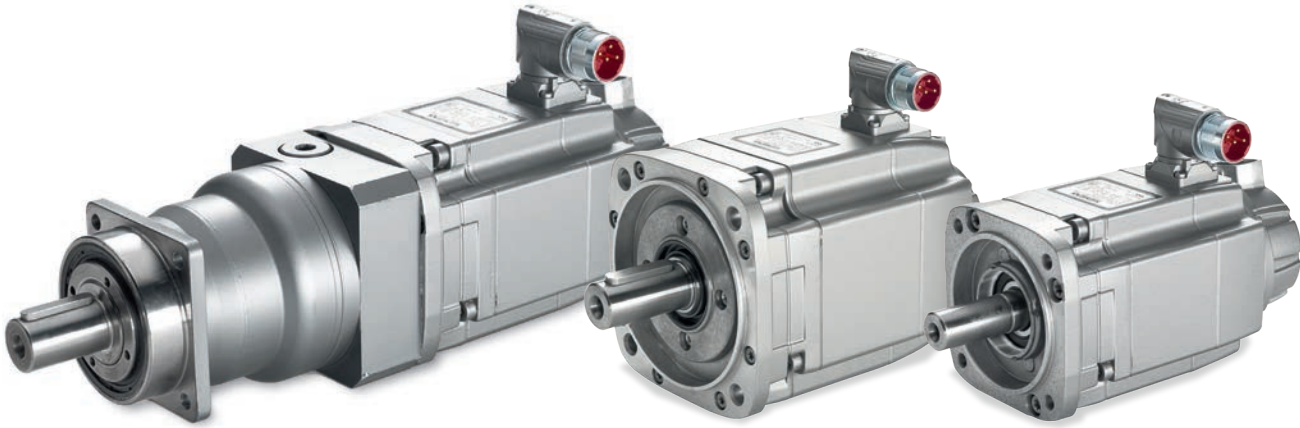

SIMOTICS S-1FK7 servomotors—overview

SIMOTICS S-1FK7	Standstill torque *	Rated speed *	Rated power *
CT—Compact	0.2–48 Nm	up to 6,000 rpm	0.05–8.2 kW
HD—High Dynamic	1.3–28 Nm	up to 6,000 rpm	0.6–3.8 kW
HI—High Inertia	3–48 Nm	up to 6,000 rpm	0.9–7.7 kW

* depending upon the version and type

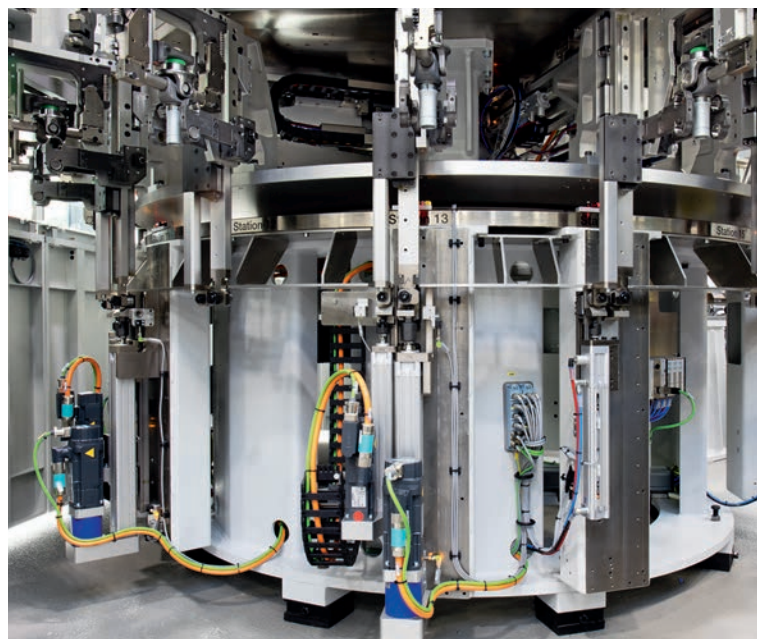
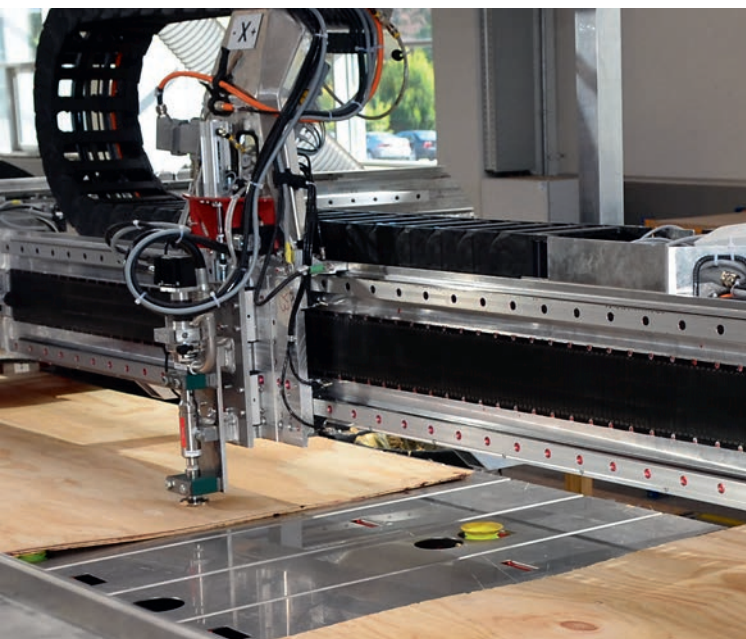

| SIMOTICS-S servomotors

SIMOTICS S-1FT7

Highlights

Two versions with different moments of inertia—
Compact, High Dynamic

High efficiency and 400% overload capability
(naturally cooled versions)

High surface quality of the workpiece through low radial
eccentricity and low torque ripple

Either naturally-cooled, forced-ventilated or water-cooled

IP67 degree of protection makes them extremely
rugged—and encoders are mounted so they are
decoupled from any oscillation and vibration

Optional absolute encoder or incremental encoder

Service- and installation-friendly using the crossover profile,
quick release connector that can be rotated and field-
replaceable encoder

Digital DRIVE-CLiQ interface with electronic type plate
for optimum connectivity to SINAMICS S120 drives

Optional: holding brake with no backlash—and planetary
gearbox with low backlash

Typical application areas

- CNC machine tools
 - Packaging machines
 - Plastics and textile machines
 - Digital printing machines
 - Conveyor technology and handling systems
 - Wood, glass, ceramic and stone processing machines
-

Maximum power and performance with customized cooling and high efficiency

Our SIMOTICS S-1FT7 servomotors are completely in their element when it comes to high-performance motion control applications in the torque range up to 280 Nm. They are available in two, highly-efficient versions with various cooling methods.

SIMOTICS S-1FT7 Compact motors (CT)

Naturally cooled, force-ventilated or water-cooled 1FT7 motors are predominantly used where space is restricted and a high power density is required. Their low torque ripple makes them ideal for machine tool applications where high surface quality finish is very critical.

SIMOTICS S-1FT7 High Dynamic motors (HD)

This version sets itself apart as a result of the extremely low intrinsic moment of inertia. This makes them the clear choice for applications demanding the highest dynamic response and shortest cycle times. 1FT7 High Dynamic motors are available with forced ventilation and water cooling—and are characterized by their high continuous power capability.

SIMOTICS S-1FT7 with mounted planetary gearboxes

When specified, we can also provide S-1FT7 motors with mounted planetary gearboxes. High-precision planetary gearboxes are available to address a wide range of applications. With these motors, you benefit from high, smooth-running properties and a high degree of compactness for motion control applications.

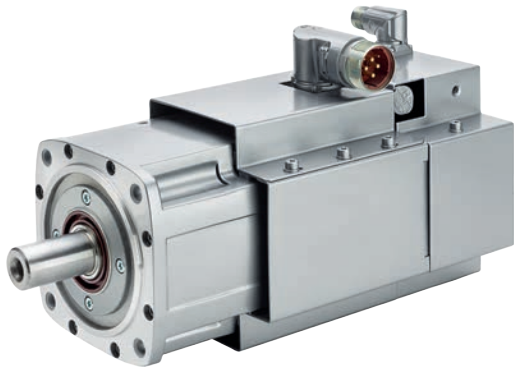

Forced ventilation

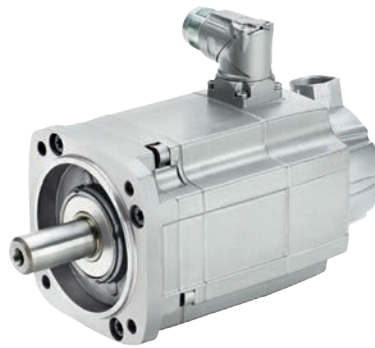

Natural cooling

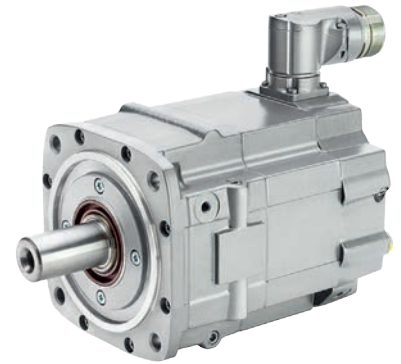

Water cooling

SIMOTICS S-1FT7 servomotors—overview

SIMOTICS S-1FK7	Standstill torque *	Rated speed *	Rated power *
CT—Compact	2–280 Nm	up to 6,000 rpm	0.88–45.5 kW
HD—High Dynamic	14–105 Nm	up to 4,500 rpm	3.8–21.7 kW

* depending upon the version and type



SIMOTICS-S servo geared motors

SIMOTICS S-1FG1

Highlights

Versions for standard (Compact) and especially fast load cycles (High Dynamic)

Naturally cooled design with a high power density

Helical gearing for very smooth operation

Wide range of versions based on four gearbox types and up to 25 ratios

High transmission ratio in the first gearbox stage allows two instead of three stage gearboxes to be used—resulting in a two percent higher efficiency with lower temperature rise

Digital DRIVE-CLiQ interface with electronic type plate for optimum connectivity to SINAMICS S120 drives

Typical application areas

- Packaging machines
- Printing machines
- Wood and metal processing
- Palletizers and storage and retrieval machines with hoisting, gantry and fork drives
- Dosing pumps and actuator drives

Open for a wide range of gearboxes

The concept of our SIMOTICS S-1FG1 servo geared motors is attractive as a result of the variable configuration options that can be used to create customized solutions—both regarding the type of construction and power rating. Irrespective of whether your application requires a helical, parallel shaft, bevel or helical worm gearbox, with high efficiencies, low torsional backlash and finely graduated ratios, these motors can optimally address a wide range of different motion control applications.

Optimum interaction

These servo geared motors are optimally adapted to the SINAMICS S120 drive system and the various commissioning tools. This facilitates seamless integration into the drive and automation environment.

Commissioning can be performed very quickly using the DRIVE-CLiQ system and electronic type plate. Pre-fabricated MOTION-CONNECT power and signal cables ensure that perfect connections can be established quickly and easily.

SIMOTICS S-1FG1 servo geared motors—overview

Geared motor type	Helical ¹⁾	Parallel shaft ¹⁾	Bevel ²⁾	Helical worm ³⁾
Gearbox designation	Z29–Z129 D29–D129	FZ29–FZ129 FD29–FD129	B29–B49 K39–K149	C29–C89
Max. drive torque (Nm)	14–1,890 (Z) 146–5,000 (D)	17–5,000 (FZ) 163–5,010 (FD)	15–465 (B) 24–8,160 (K)	46–1,480
Range of transmission ratios	3.4–62.5 (Z) 39.3–373 (D)	3.6–65.2 (FZ) 46.4–413 (FD)	3.5–59.3 (B) 5.2–244.3 (K)	6.2–102.5

¹⁾ 2-stage (Z), 3-stage (FD) ²⁾ 2-stage (B), 3-stage (K) ³⁾ 2-stage



Helical geared motor

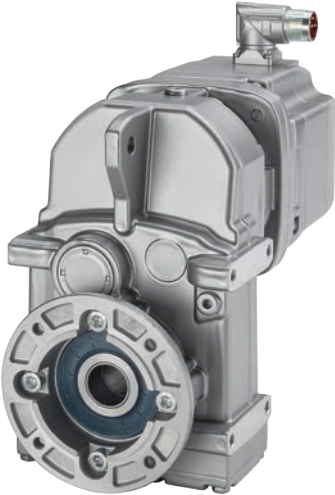

Parallel shaft geared motor

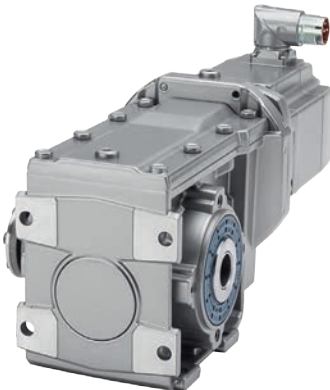

Bevel geared motor

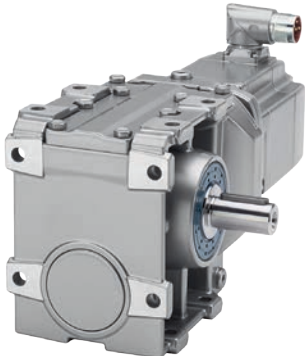

Helical worm geared motor



Our servo-drive systems can be simply engineered for your application

SIMOTICS S-1FL6 and SINAMICS V90

Highlights

Two versions with different moments of inertia—Low and High Inertia

300% overload capability and high IP65 degree of protection

With either incremental or absolute encoder

Quick release connector for simple motor installation

Servo tuning and machine optimization using the auto-tuning function

All frame sizes have an integrated braking resistor

Optional with / without brake—as well as with plain shaft or feather key



Typical application areas

- Handling systems, automatic equipping and assembly machines
- Packaging and labeling machines
- Metal-forming machines
- Printing machines
- Winders and unwinders

Can be flexibly configured in the lower power range

Together with SINAMICS V90 drives, SIMOTICS S-1FL6 servomotors form a seamlessly integrated drive system with eight drive sizes and seven motor versions. Based upon their optimized moment of inertia, the motors handle continuous motion such as winding and punching—with very high, smooth running characteristics. Versions with a very low moment of inertia are available for motion sequences demanding a high dynamic performance with high positioning accuracy.

SIMOTICS S-1FL6 servomotors—overview

SIMOTICS S-1FL6	Standstill torque *	Rated speed *	Rated power *
LI—Low Inertia	0.16–6.37 Nm	up to 5,000 rpm	0.05 – 2.0 kW
HI—High Inertia	1.27–33.4 Nm	up to 3,000 rpm	0.4 – 7.0 kW

* depending upon the version and type



SIMOTICS S-1FK2/1FT2/1FS2 and SINAMICS S210

Highlights

Two versions with different moments of inertia—
Compact and High Dynamic

High efficiency and 300% overload capability

With either multi-turn absolute or absolute encoder

Extremely simple to commission with web-server, motor parameters are automatically read in—and the drive system can be perfectly optimized using the One Button Tuning function

One Cable Connection (OCC) to connect the motor to the drive



Typical application areas

- Packaging machines and filling systems
- Feeding, removing, mounting and stacking systems
- Wood, glass, ceramic and stone processing machines
- Digital printing machines
- Plastics and textile machines
- CNC machine tools
- Robots and handling systems

Perfect interaction to address high requirements

SIMOTICS S-1FK2 motors have been specifically developed for use with SINAMICS S210 drives—to create a servo-drive system with five power classes from 50 up to 6,400 watts. This means that low loads can be moved with an extremely high dynamic response and high loads can be positioned with a high degree of precision. Motors are connected to the drives through an innovative connection system called One Cable Connection—OCC with quick release. This combines power conductors, encoder signal and brake in one thin cable along with a single, compact plug connector that can be rotated—simplifying installation and increasing drive ruggedness.

SIMOTICS S-1FK2 servomotors—overview

SIMOTICS S-1FK2	Standstill torque *	Rated speed *	Rated power *
CT—Compact	0.64–40 Nm	3,000 rpm	0.2–6.4 kW
HD—High Dynamic	0.16–16 Nm	3,000 rpm	0.05–3.3 kW





* depending upon the version and type

Note:

1. SIMOTICS S-1FT2 servomotors have similar overview data with additional options.
2. SIMOTICS S-1FS2 servomotors are available with food grade stainless steel shaft/housing and no edges.
Degree of protection for housing IP69K (max 30 bar). Suitable for Cleaning in Place (CIP).
Standstill torque 3–23 Nm Rated speed up to 3,000 rpm Rated power 0.8–2.5 kW

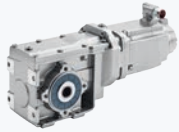

SIMOTICS motion control motors—an overview

SIMOTICS				
	S-1FK7	S-1FT7	S-1FG1	S-1FL6
Servomotors			Servo-drive systems	
Cooling method				
Natural cooling	Yes	Yes	Yes	Yes
Forced-ventilated	Yes	Yes	—	—
Water-cooled	—	Yes	—	—
Open-circuit-cooled	—	—	—	—
Shaft height	20 ... 100	36 ... 132	29...109	20 ... 90
Degree of protection	IP64 to IP65	IP64 to IP67	IP65	IP65
Rated speed / velocity	2,000 ... 6,000 rpm	1,500 ... 6,000 rpm	13 ... 1,279 rpm	2,000 ... 5,000 rpm
Rated power	0.05 ... 8.17 kW	0.88 ... 45.5 kW	0.5 ... 1.8 kW	0.05 ... 7.0 kW
Rated Nm torque / force	0.08 ... 37 Nm	1.4 ... 250 Nm	up to 3,070 Nm ¹⁾	0.16 ... 33.4 Nm
Encoder				
Single-turn absolute	Yes	Yes	Yes	Yes
Multi-turn absolute	Yes	Yes	Yes	Yes
Incremental	Yes	Yes	—	Yes
Resolver	Yes	—	Yes	—
External required	—	—	—	—
Holding brake as option	Yes	Yes	Yes	Yes
Drive systems	SINAMICS S120	SINAMICS S120	SINAMICS S120	SINAMICS V90
Catalogs				
D21.4 SINAMICS S120 and SIMOTICS	Yes	Yes	—	—
D31.1 SINAMICS drives for single axis drives / built-in units	Yes	Yes	—	—
D32 SINAMICS S210 servo-drive systems	—	—	—	—
D33 SINAMICS V90 basis servo-drive system	—	—	—	Yes
D41 SIMOTICS S-1FG1 servo geared motor	—	—	Yes	—
NC62 SINUMERIK CNC systems for machine tools	Yes	Yes	—	—

¹⁾ Dependent upon the geared motor

 S-1FK2/1FT2/1FS2	 M-1PH8	 M-1FE1, M-1FE2	 L-1FN3	 T-1FW3	 T-1FW6
Main motors		Linear motor		Torque motors	
Yes	—	—	—	—	Yes
—	Yes	—	—	—	—
—	Yes	Yes	Yes	Yes	Yes
—	Yes	—	—	—	—
20 ... 100	80 ... 355	40 ... 180	—	150 ... 280	159 ... 730 ⁴⁾
IP64 to IP67	IP23, IP55, IP65	IP00	IP65	IP54/IP55	IP23
3,000 rpm	400 ... 10,000 rpm	500 ... 25,000 rpm	up to 836 m/min ²⁾	150 ... 1,200 rpm	38 ... 940 rpm
0.05 ... 7.5 kW	2.8 ... 1,340 kW	4.0 ... 159 kW	1.7 ... 81.9 kW	2.8 ... 380 kW	1.7 ... 54.1 kW
0.16 ... 34.5 Nm	2.9 ... 12,435 Nm	up to 1,530 Nm	150 ... 10,375 N ₃ ³⁾	100 ... 7,000 Nm	10 ... 5,760 Nm
Yes	—	—	—	Yes	—
Yes	Yes	—	—	Yes	—
—	Yes	—	—	Yes	—
—	—	—	—	Yes	—
—	—	Yes	Yes	—	Yes
Yes	Yes	—	—	—	—
SINAMICS S210	SINAMICS S120, G120	SINAMICS S120	SINAMICS S120	SINAMICS S120	SINAMICS S120
—	Yes	—	Yes	Yes	Yes
—	Yes	—	—	—	—
Yes	—	—	—	—	—
—	—	—	—	—	—
—	—	—	—	—	—
—	Yes	Yes	Yes	—	Yes

²⁾ Maximum velocity at rated force (feed force F_N)

³⁾ Rated force (feed force F_N)

⁴⁾ Outer stator diameter

**Published by
Siemens Industry, Inc.**

100 Technology Drive
Alpharetta, GA 30005

(770) 871-3800

Order No. DRBR-SIMOTICS-0822

Printed in USA
© 08.2022 Siemens Industry, Inc.

usa.siemens.com/motioncontrol

This brochure contains only general descriptions or performance features, which do not always apply in the manner described in concrete application situations or may change as the products undergo further development. Performance features are valid only if they are formally agreed upon when the contract is closed.

Siemens is a registered trademark of Siemens AG. Product names mentioned may be trademarks or registered trademarks of their respective companies.

Specifications are subject to change without notice.